

DESPIECE DESLIZADOR LINEAL UTN

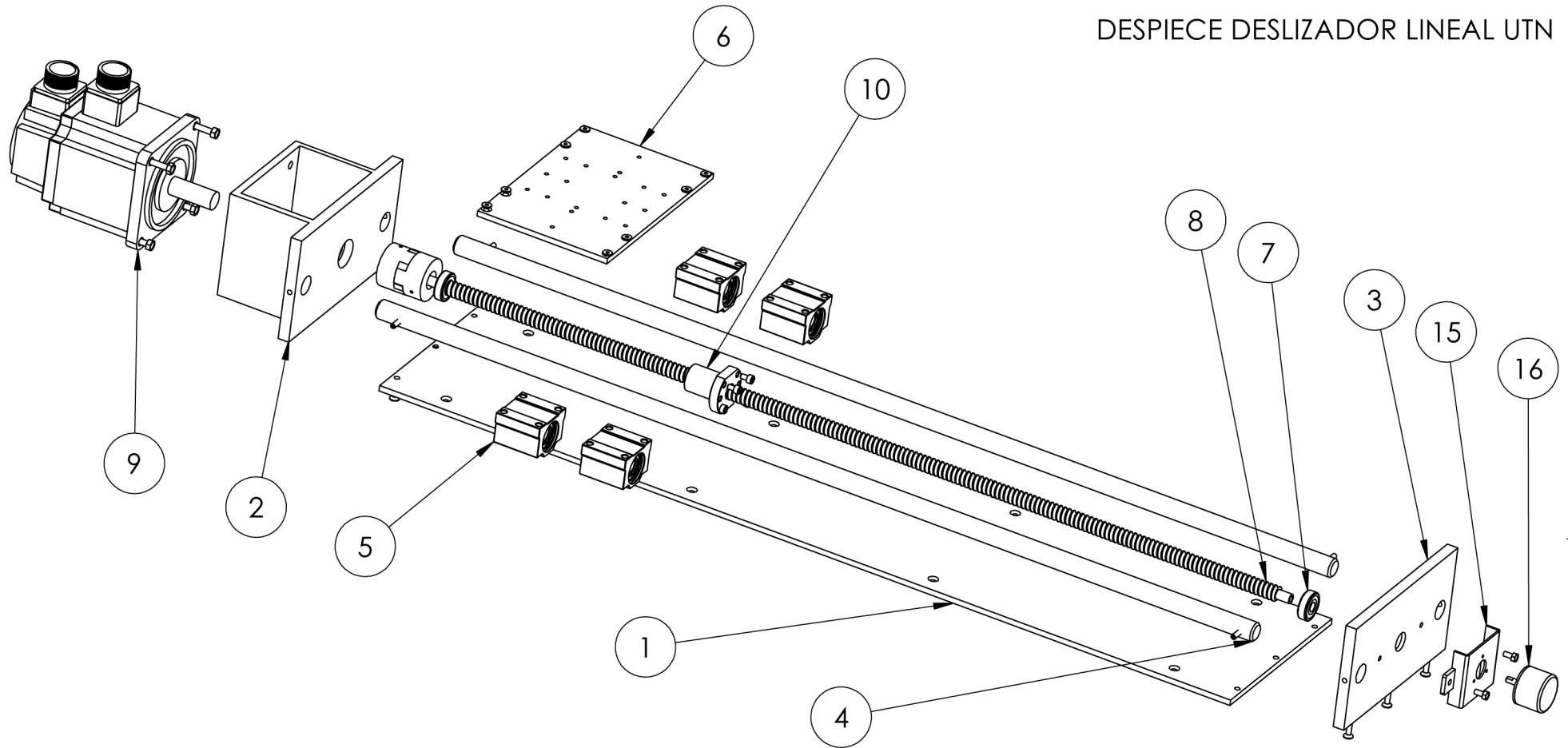

Nota: Lista de material en número de sustitución DESLIZADOR_LINEAL_UTN

			Tolerancia: + - 1	Masa: 45 KG	Materiales: ACERO ASTM - A500
			Dib.	Fecha: 04/07/2014	Nombre: PALACIOS E.
			Rev.	07/07/2014	TERÁN D.
			Apro.	07/07/2014	TERÁN D.
			Firma: <i>Ernesto P.</i>		
			Denominación: Deslizador Lineal UTN		
			Número del dibujo: DESLIZADOR_DISSASSEMBLY		
			Escala: 1:5		
			Registro:		
			Sustitución:		

TORNILLO DE BOLAS

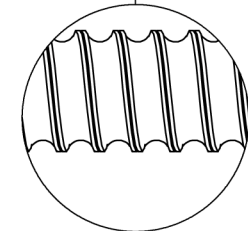
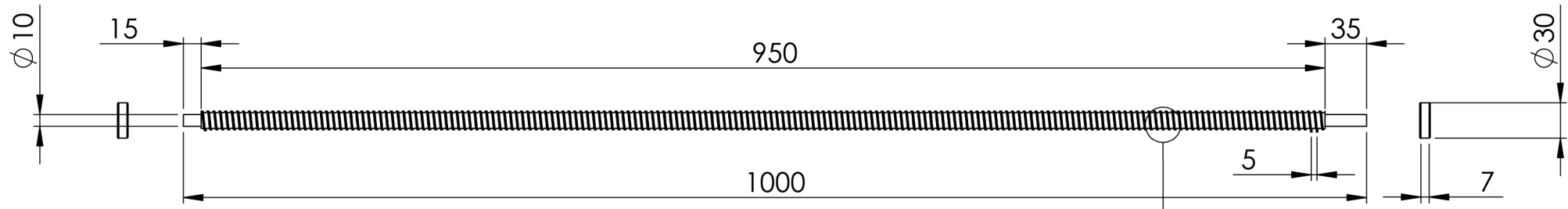

Vista Isometrica (1:15)

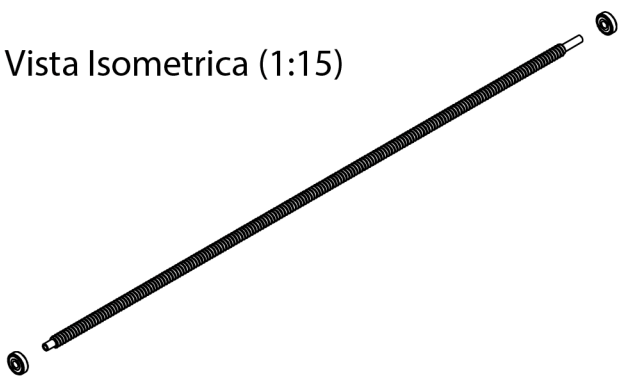

			Tolerancia:	Masa:	Materiales:	
			+ - 1	2 KG	ACERO ENDURECIDO ASTM - A500	
				Fecha:	Nombre:	Denominación:
			Dib.	04/07/204	PALACIOS E.	
			Rev.	07/07/2014	TERÁN D.	
			Apro.	07/07/2014	TERÁN D.	Escala: 1:10
			Firma:			
						Número del dibujo:
				DZL-UTN-02		
			Sustitución:	Unidades: milímetros		

ELEMENTOS EJE VISTA SUPERIOR

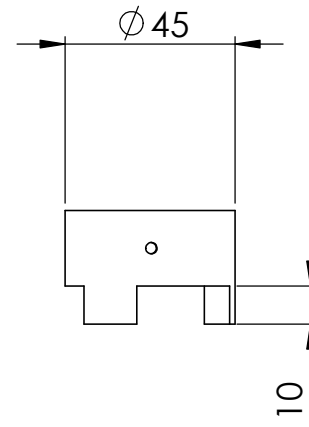
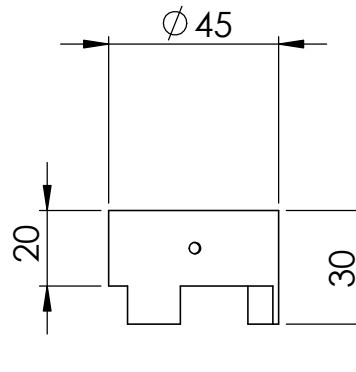
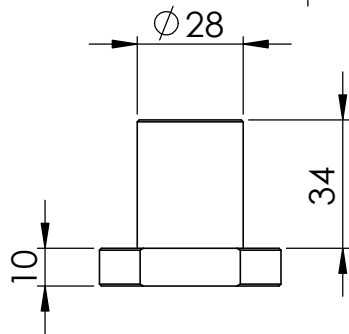
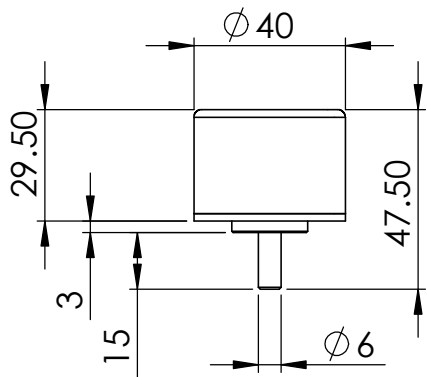

ELEMENTOS EJE VISTA FRONTAL

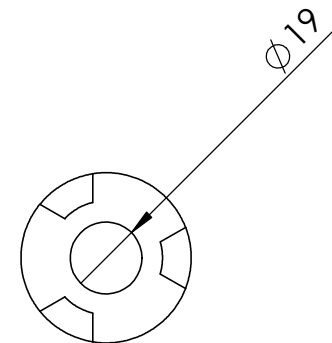
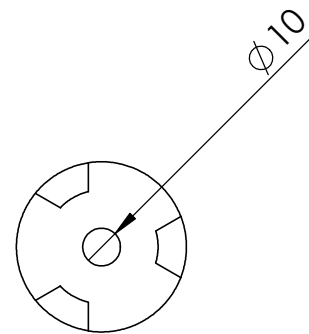
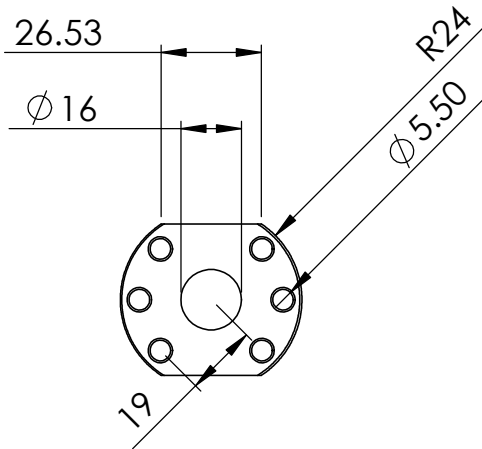
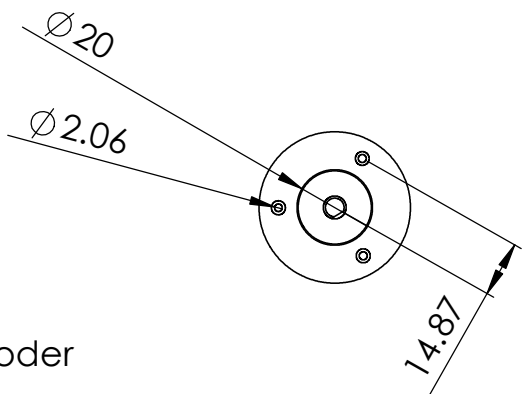

Encoder

Nuez

Matrimonio

Extremo tornillo

Extremo Motor

Tolerancia:	Masa:	Materiales:
+ - 1	2 KG	ACERO ASTM - A500
Fecha:	Nombre:	Denominación:
04/07/2014	PALACIOS E.	Elementos eje
Rev. 07/07/2014	TERÁN D.	Número del dibujo: DZL-UTN-03
Apro. 07/07/2014	TERÁN D.	

Firma:
Ernesto P.

Escala:	Registro:
1:2	
Sustitución:	Unidades: milímetros

PLACA CARRO DESLIZADOR

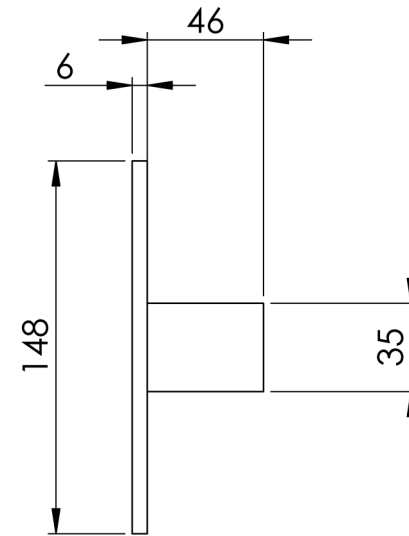
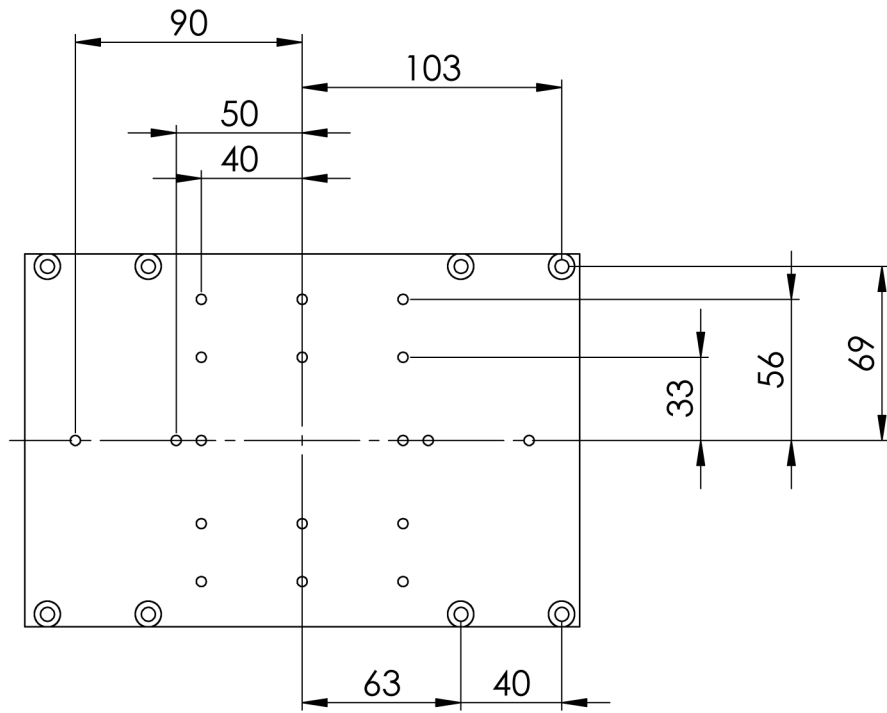

VISTA ISOMÉTRICA (1:5)

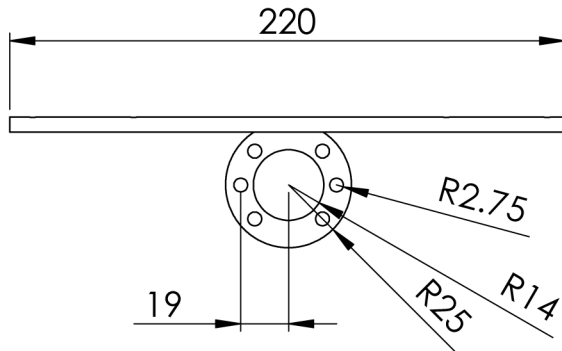
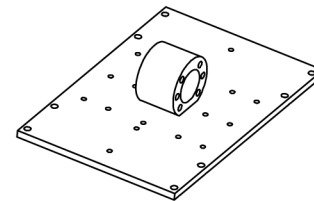

			Tolerancia: + - 1	Masa: 3 KG	Materiales: ACERO ASTM - A500			
					Denominación:	Escala:		
					Placa deslizador	1:5		
							Número del dibujo:	Registro:
							DZL-UTN-04	
			Firma: <i>Ernesto P.</i>		Sustitución:	Unidades: milímetros		

