

DETALLE Z
ESCALA 1:2

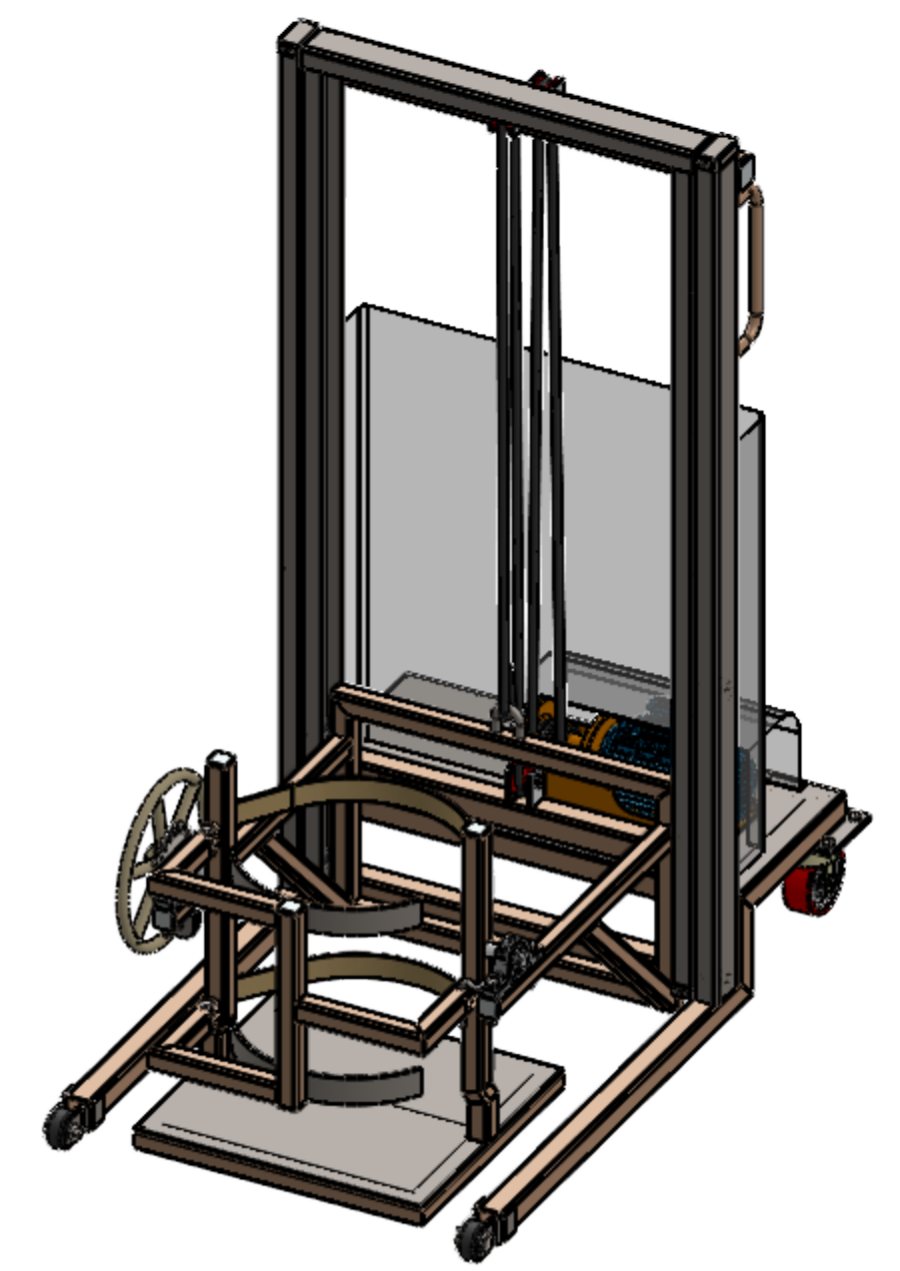
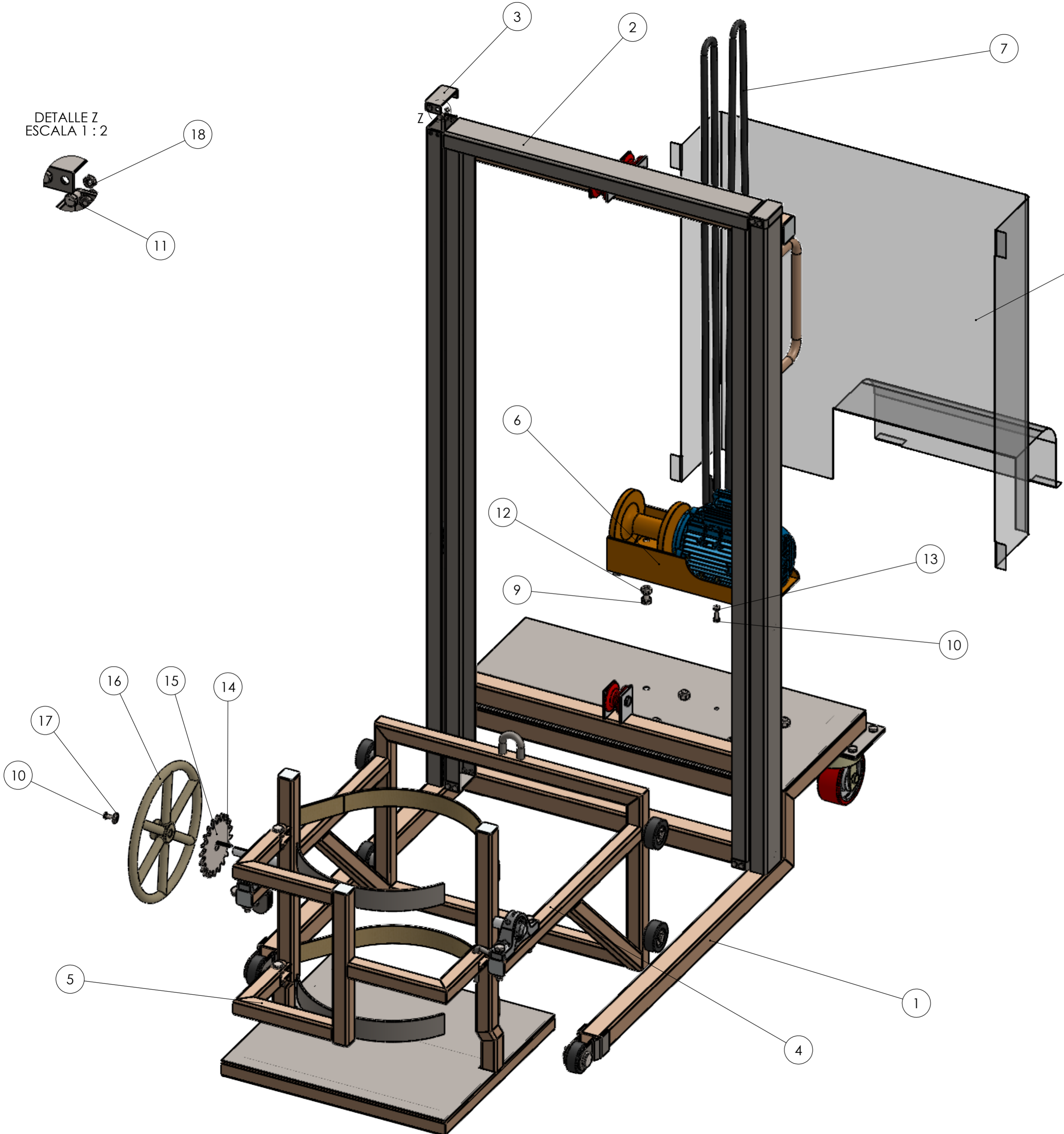

18	TUERCA M5X0.8	B-2	16		
17	RODELA	F-1	1		RODELA PLANA Ø8mm
16	VOLANTE	E-2	1	EBL-001-000-003	ACERO GALVANIZADO
15	PIÑÓN	E-2	1		PIÑÓN DE DIENTES RECTOS, #DIENTES: 20, 220°, Ø PRIMITIVO: 4", DP: 5, A. DE CARA: 0.2"
14	CUÑA DE AJUSTE	E-2	1		36X3.18X2.62
13	TUERCA M6X1	D-7	4		
12	TUERCA M10X1.5	D-4	6		
11	PERNO M5X0.8X8	C-2	16		
10	PERNO M6 x 1.0 x 16	E-8	5		
9	PERNO M10 x 1.5 x 16	E-4	6		
8	PROTECCIÓN	B-9	1	EBL-001-000-001	ACERO GALVANIZADO
7	CABLE DE ACERO	A-8	1		Ø4mm, CARGA DE ROTURA 1400kg
6	CONJUNTO 6	D-4	1		POLIPASTO 100kg
5	CONJUNTO 7	G-1	1	EBL-001-007-000	
4	CONJUNTO 3	H-6	1	EBL-001-003-000	
3	TAPA	A-4	4	EBL-001-000-002	ASTM A36
2	CONJUNTO 2	A-5	1	EBL-001-002-000	
1	CONJUNTO 1	H-7	1	EBL-001-001-000	
N.º	DENOMINACIÓN	ZONA	CANTIDAD	CÓDIGO	OBSERVACIÓN

UTN
UNIVERSIDAD TÉCNICA DEL NORTE
SANTA - ECUADOR

PROYECTO: ELEVADOR DE BIDONDES DE LECHE
CONJUNTO: GENERAL
CÓDIGO: EBL-001-000-000

ESCALA:
1:5

		DISEÑO	JUAN C.	28/07/23	HOJA 1/1
PESO:	495N	DIBUJÓ	JUAN C.	28/07/23	
LARGO:	1060mm	REVISÓ	VICTOR E.	05/08/23	
ANCHO:	648mm	APROBÓ	VICTOR E.	05/08/23	
ALTO:	1340mm				

FICA
CIME

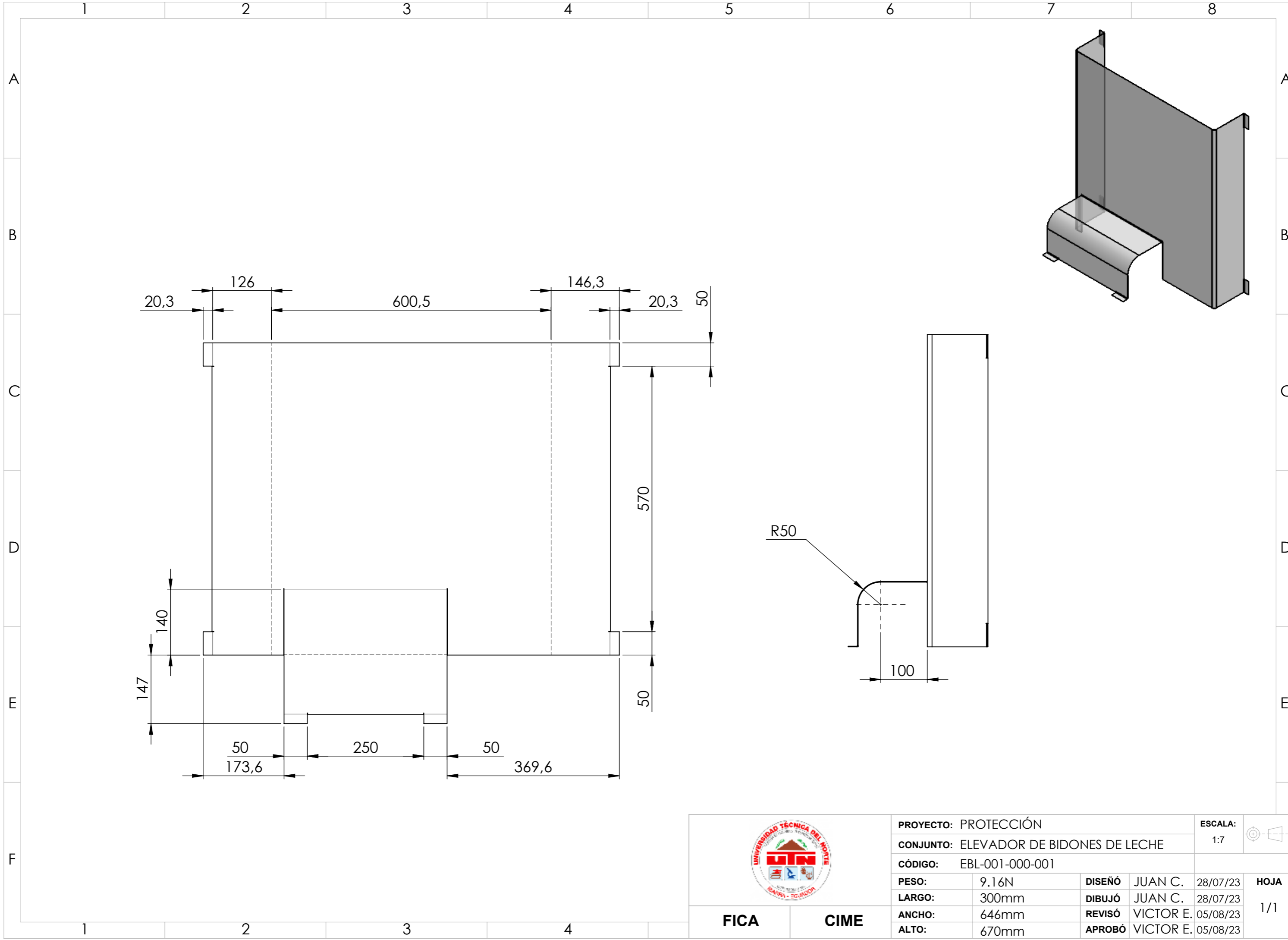

	PROYECTO: PROTECCIÓN				ESCALA:	
	CONJUNTO: ELEVADOR DE BIDONES DE LECHE				1:7	
	CÓDIGO: EBL-001-000-001					
	PESO:	9.16N	DISEÑÓ	JUAN C.	28/07/23	HOJA 1/1
	LARGO:	300mm	DIBUJÓ	JUAN C.	28/07/23	
ANCHO:	646mm	REVISÓ	VICTOR E.	05/08/23		
ALTO:	670mm	APROBÓ	VICTOR E.	05/08/23		
FICA	CIME					

1

2

3

4

A

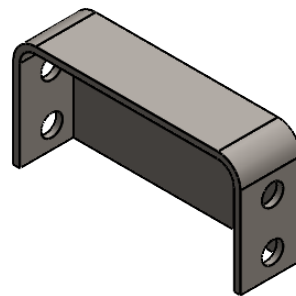

B

2xR 6,3

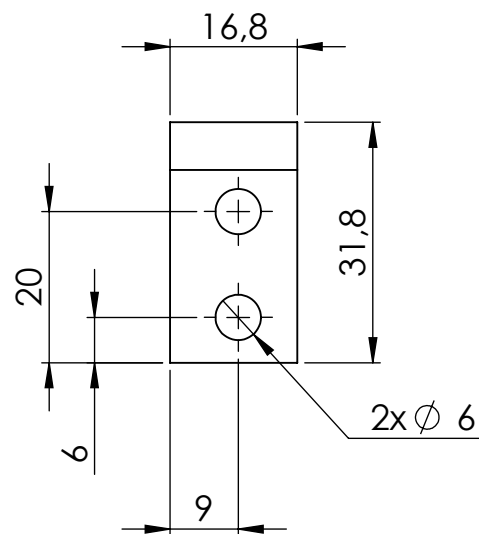
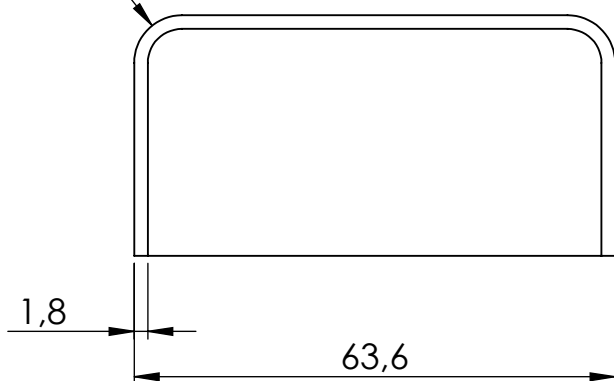

C

D

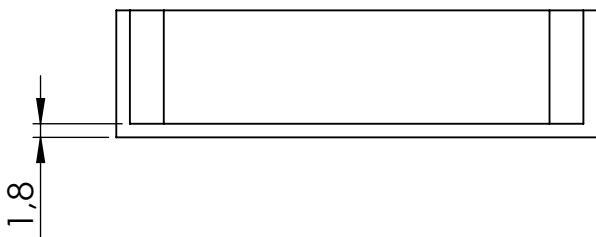

E



PROYECTO: TAPA

ESCALA:



CONJUNTO: ELEVADOR DE BIDONES DE LECHE

1:1

CÓDIGO: EBL-001-000-002

MASA: 0.5N

DISEÑO: JUAN C. 28/07/23

HOJA

LARGO: 31.8mm

DIBUJÓ: JUAN C. 28/07/23

1/1

ANCHO: 63.6mm

REVISÓ: VICTOR E. 05/08/23

FICA

CIME

ALTO: 16.8mm

APROBÓ: VICTOR E. 05/08/23

DETALLE Z
ESCALA 2:1

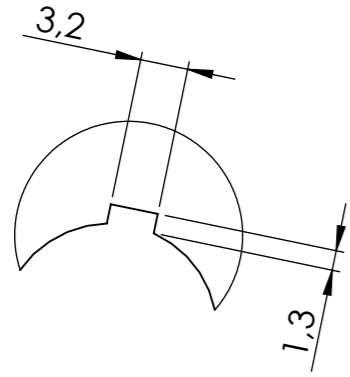

Ø 250

6x 60°

Ø 14,3

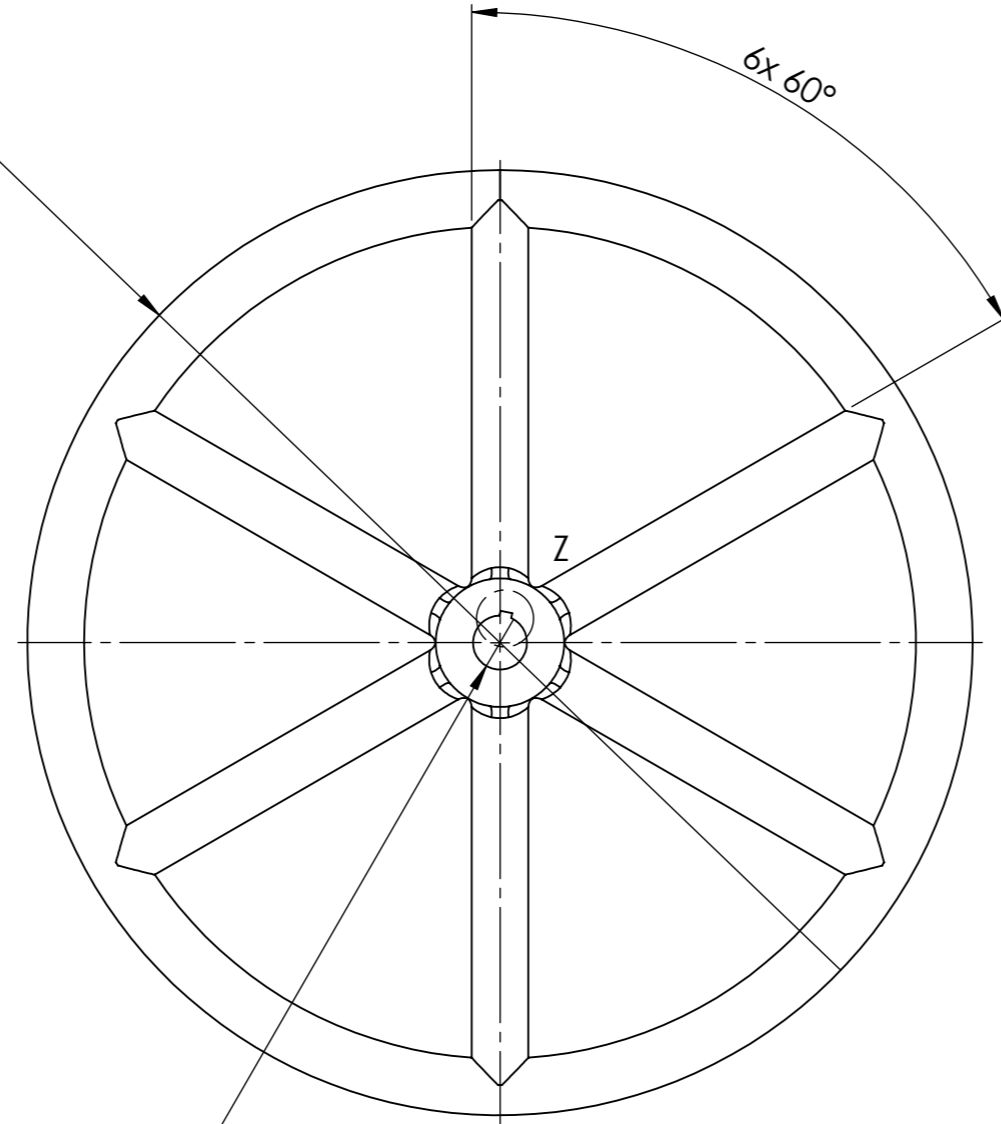

2,50

Ø 34

30

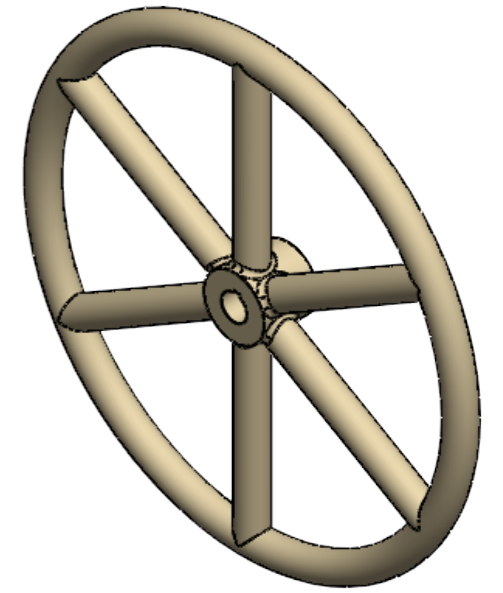
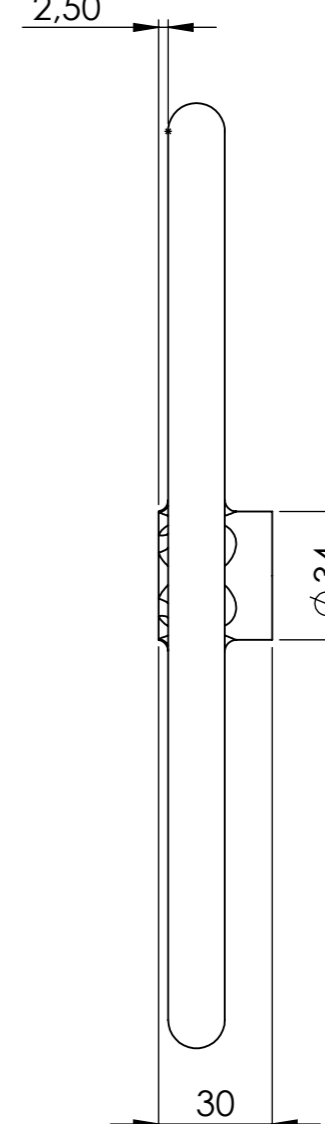

TUBO ESTRUCTURAL REDONDO Ø 7/8" ESPESOR 1.5mm



FICA

CIME

PROYECTO: VOLANTE				ESCALA:	
CONJUNTO: ELEVADOR DE BIDONDES DE LECHE				1:8	
CÓDIGO: EBL-001-000-003					
PESO:	2.5N	DISEÑO	JUAN C.	28/07/23	HOJA 1/1
LARGO:	250mm	DIBUJÓ	JUAN C.	28/07/23	
ANCHO:	250mm	REVISÓ	VICTOR E.	05/08/23	
ALTO:	30mm	APROBÓ	VICTOR E.	05/08/23	

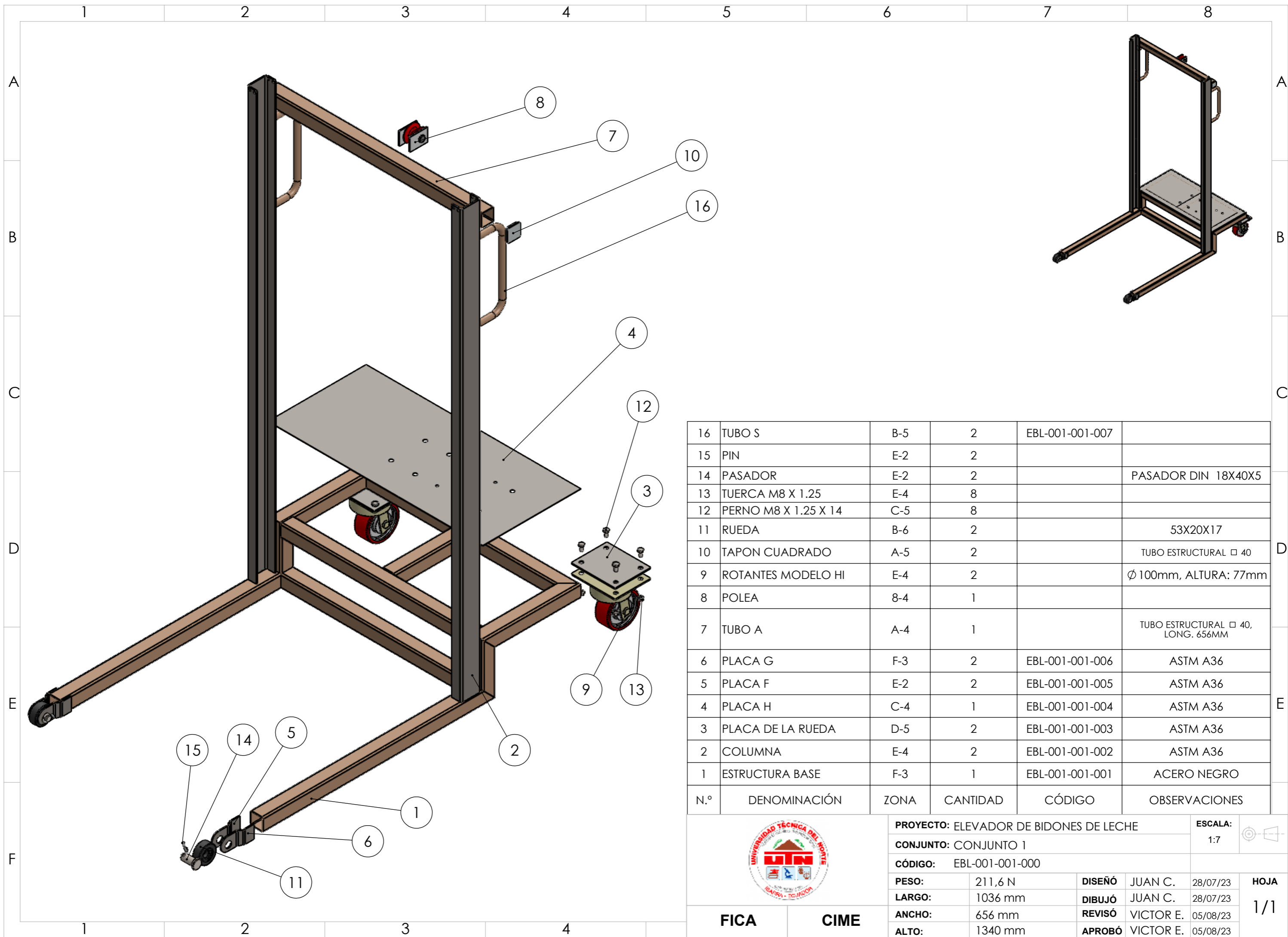

16	TUBO S	B-5	2	EBL-001-001-007	
15	PIN	E-2	2		
14	PASADOR	E-2	2		PASADOR DIN 18X40X5
13	TUERCA M8 X 1.25	E-4	8		
12	PERNO M8 X 1.25 X 14	C-5	8		
11	RUEDA	B-6	2		53X20X17
10	TAPON CUADRADO	A-5	2		TUBO ESTRUCTURAL □ 40
9	ROTANTES MODELO HI	E-4	2		∅ 100mm, ALTURA: 77mm
8	POLEA	8-4	1		
7	TUBO A	A-4	1		TUBO ESTRUCTURAL □ 40, LONG. 656MM
6	PLACA G	F-3	2	EBL-001-001-006	ASTM A36
5	PLACA F	E-2	2	EBL-001-001-005	ASTM A36
4	PLACA H	C-4	1	EBL-001-001-004	ASTM A36
3	PLACA DE LA RUEDA	D-5	2	EBL-001-001-003	ASTM A36
2	COLUMNA	E-4	2	EBL-001-001-002	ASTM A36
1	ESTRUCTURA BASE	F-3	1	EBL-001-001-001	ACERO NEGRO
N.º	DENOMINACIÓN	ZONA	CANTIDAD	CÓDIGO	OBSERVACIONES



PROYECTO: ELEVADOR DE BIDONES DE LECHE				ESCALA: 1:7	
CONJUNTO: CONJUNTO 1					
CÓDIGO: EBL-001-001-000					
PESO:	211,6 N	DISEÑO	JUAN C.	28/07/23	HOJA 1/1
LARGO:	1036 mm	DIBUJÓ	JUAN C.	28/07/23	
ANCHO:	656 mm	REVISÓ	VICTOR E.	05/08/23	
ALTO:	1340 mm	APROBÓ	VICTOR E.	05/08/23	

FICA **CIME**

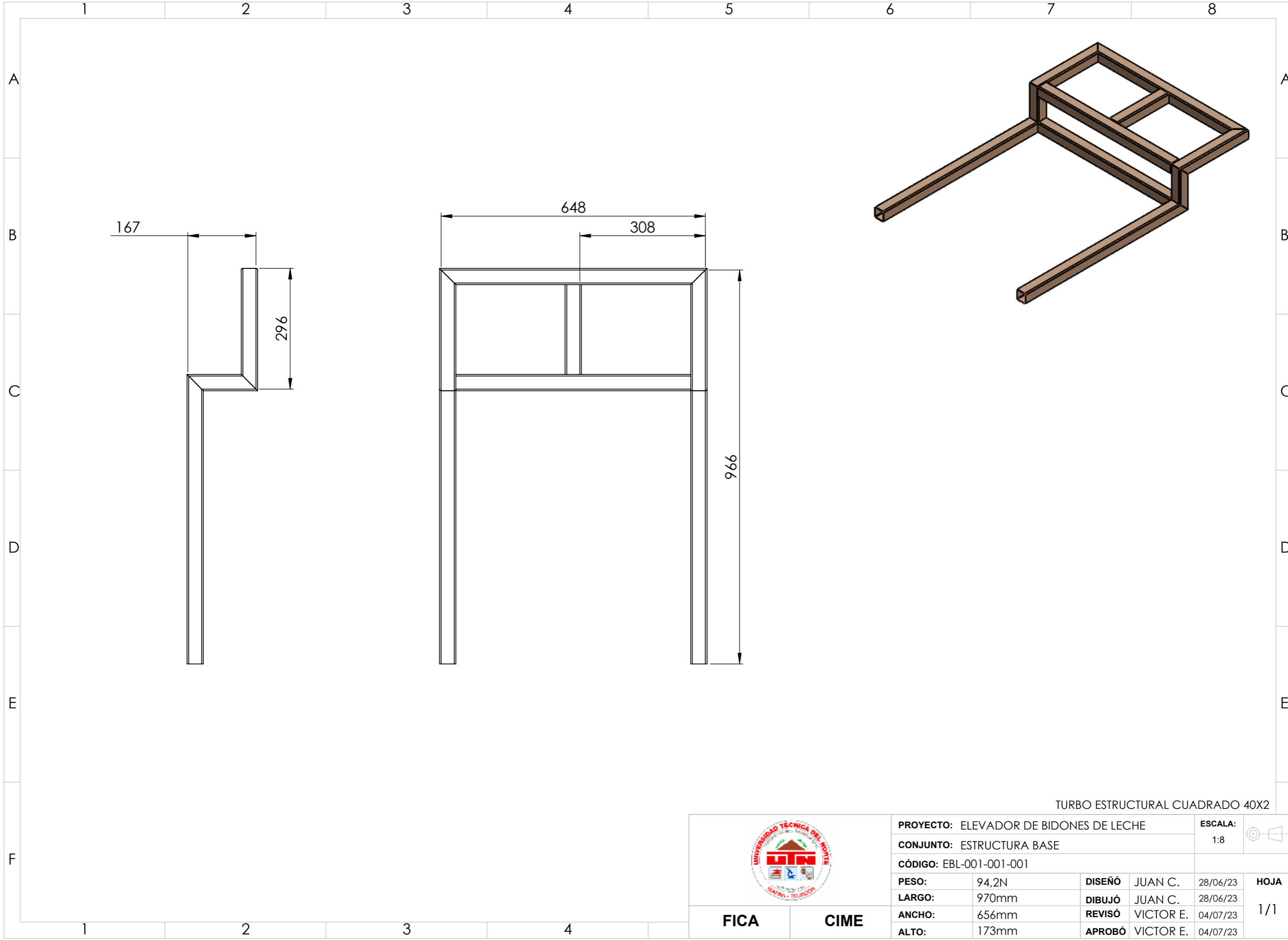

TURBO ESTRUCTURAL CUADRADO 40X2

	PROYECTO: ELEVADOR DE BIDONES DE LECHE			ESCALA:	
	CONJUNTO: ESTRUCTURA BASE			1:8	
CÓDIGO: EBL-001-001-001					
PESO:	94,2N	DISEÑO	JUAN C.	28/06/23	HOJA 1/1
LARGO:	970mm	DIBUJÓ	JUAN C.	28/06/23	
ANCHO:	656mm	REVISÓ	VICTOR E.	04/07/23	
ALTO:	173mm	APROBÓ	VICTOR E.	04/07/23	
FICA	CIME				

1

2

3

4

A

B

C

D

E

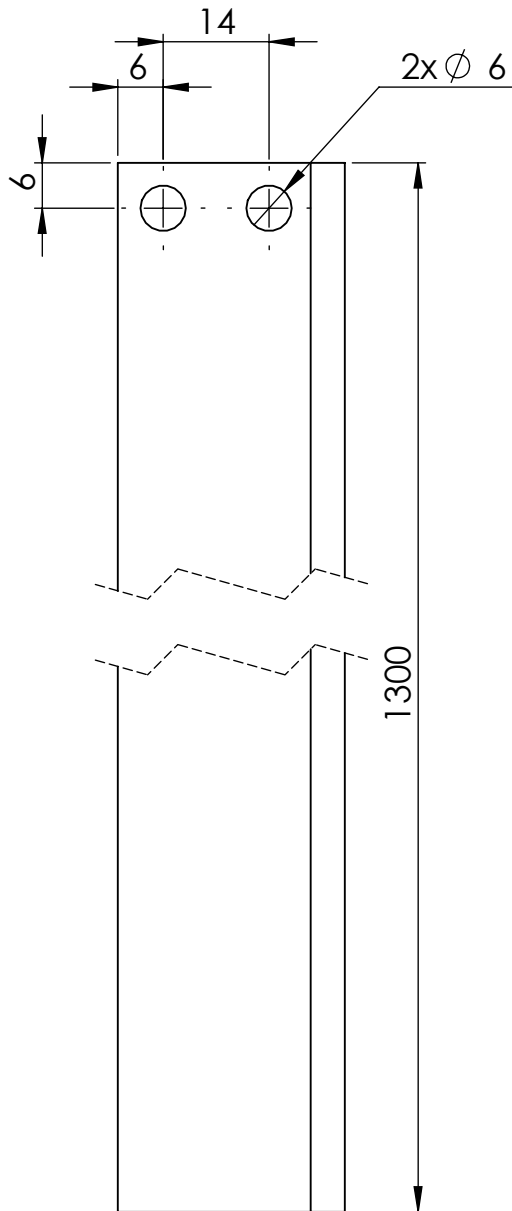

PERFIL TIPO U 60X30X3



PROYECTO: ELEVADOR DE BIDONES DE LECHE

ESCALA:



CONJUNTO: COLUMNA

1:1

CÓDIGO: EBL-001-001-002

MASA: 34N

DISEÑO: JUAN C.

28/07/23

HOJA

LARGO: 1300mm

DIBUJÓ: JUAN C.

28/07/23

1/1

ANCHO: 30mm

REVISÓ: VICTOR E.

05/08/23

FICA

CIME

ALTO: 60mm

APROBÓ: VICTOR E.

05/08/23

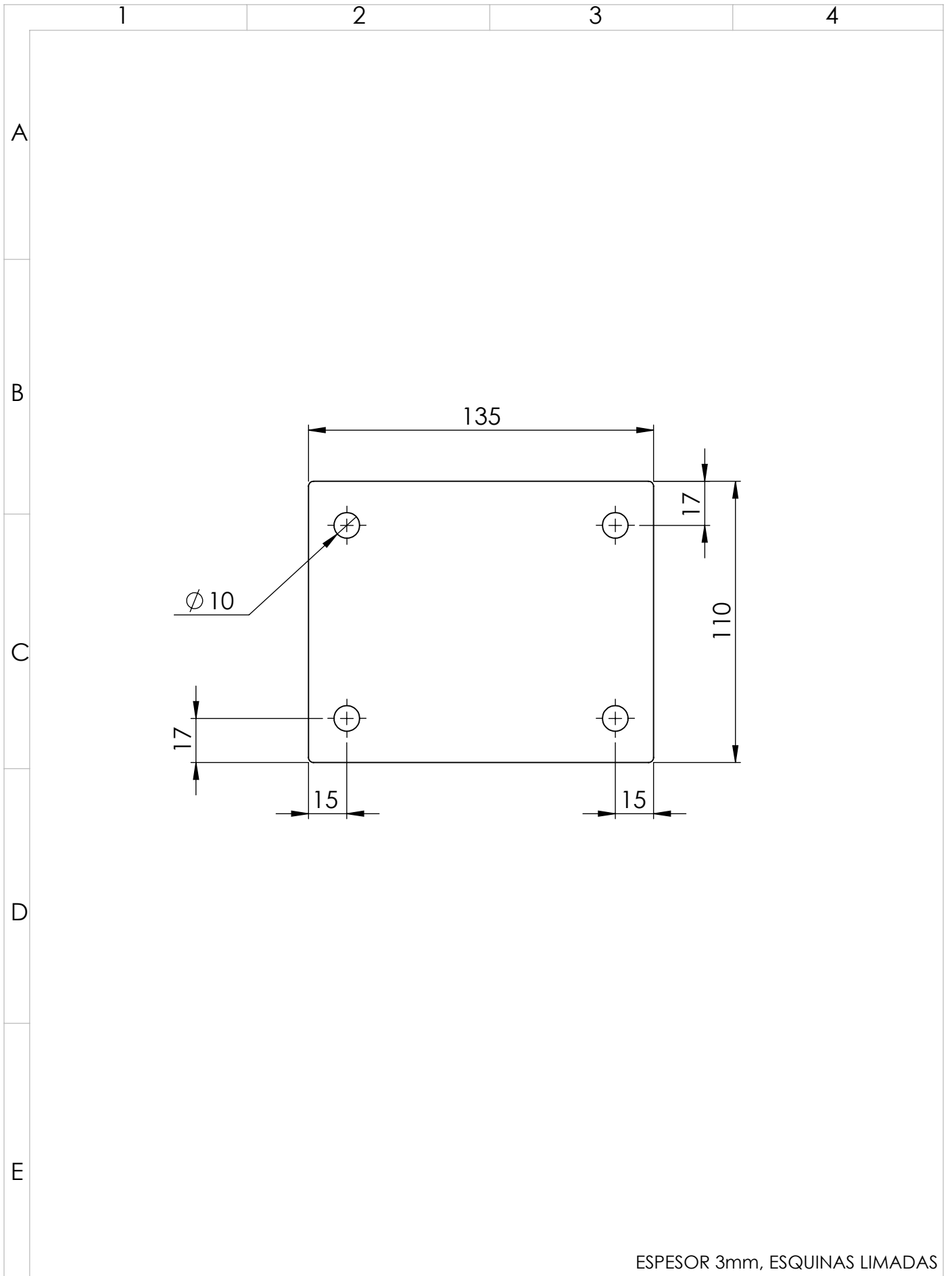

ESPESOR 3mm, ESQUINAS LIMADAS

	PROYECTO: ELEVADOR DE BIDONES DE LECHE		ESCALA:			
	CONJUNTO: PLACA DE LA RUEDA		1:2			
	CÓDIGO: EBL-001-001-003					
	PESO:	3.4N	DISEÑO	JUAN C. 28/07/23		HOJA 1/1
	LARGO:	110mm	DIBUJÓ	JUAN C. 28/07/23		
ANCHO:	135mm	REVISÓ	VICTOR E. 05/08/23			
ALTO:	3mm	APROBÓ	VICTOR E. 05/08/23			
FICA	CIME					

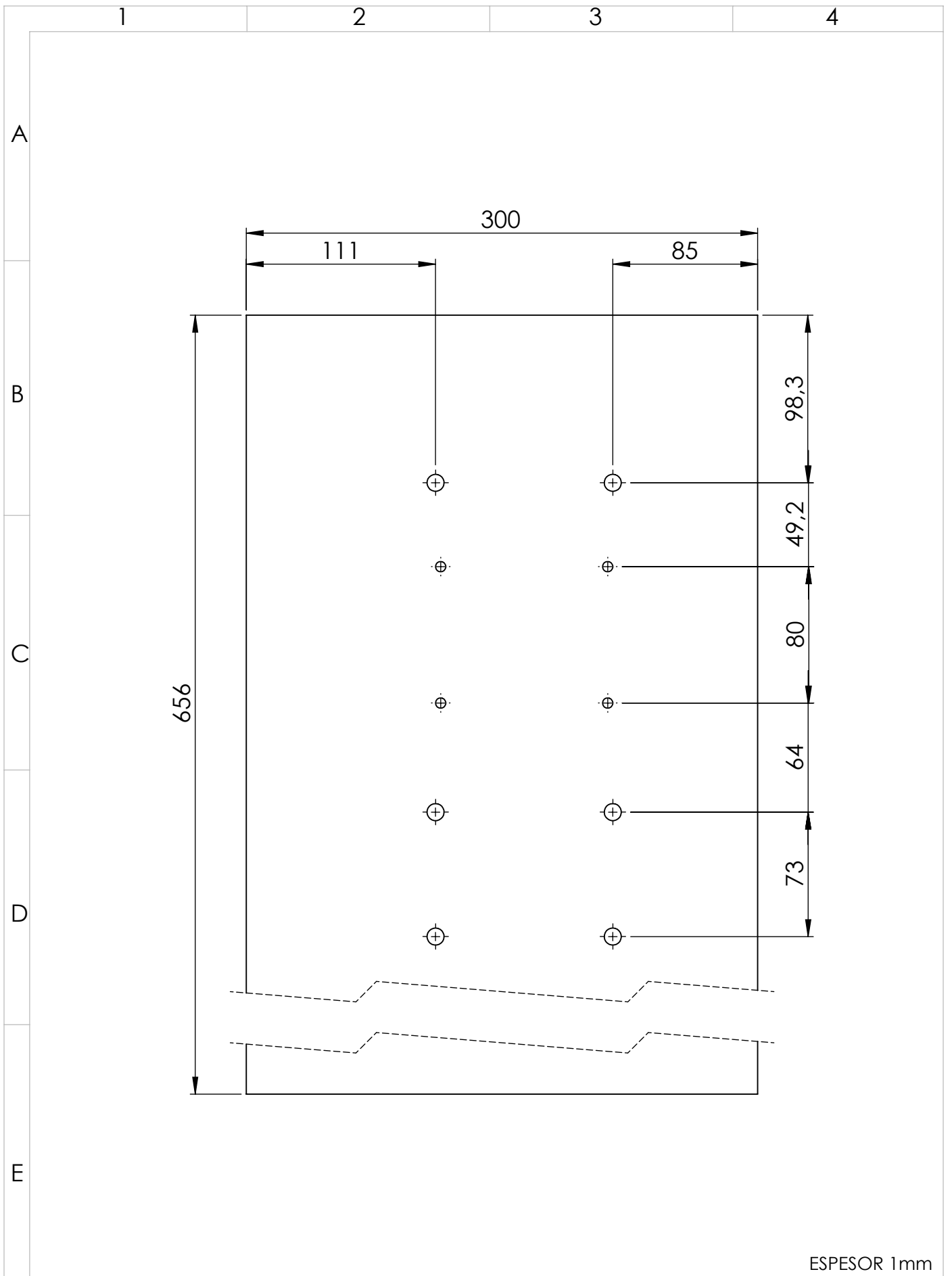

ESPESOR 1mm



PROYECTO: ELEVADOR DE BIDONES DE LECHE

ESCALA:



CONJUNTO: PLACA H

1:3

CÓDIGO: EBL-001-001-004

PESO: 15N

DISEÑO JUAN C. 28/07/23

28/07/23

HOJA

LARGO: 656mm

DIBUJÓ JUAN C. 28/07/23

28/07/23

1/1

ANCHO: 300mm

REVISÓ VICTOR E. 05/08/23

05/08/23

ALTO: 1mm

APROBÓ VICTOR E. 28/07/23

28/07/23

FICA

CIME

1

2

3

4

A

B

C

D

E

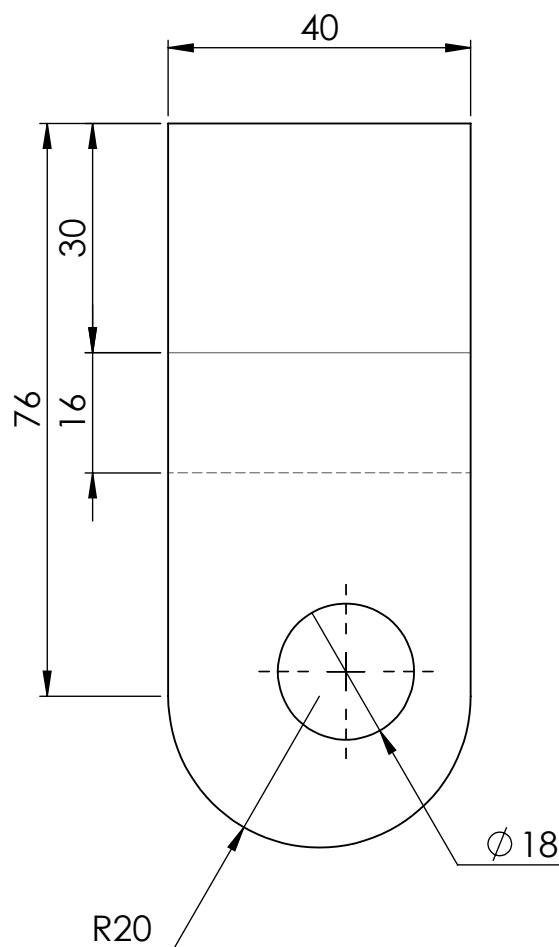
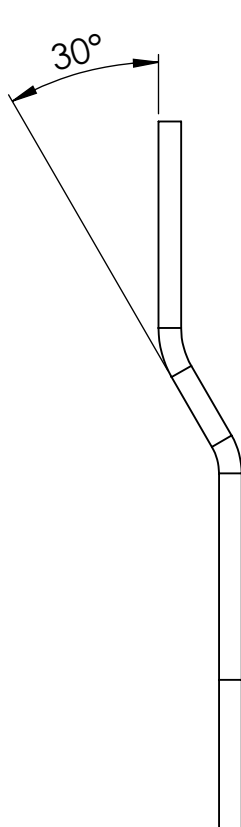

ESPESOR 3mm



PROYECTO: ELEVADOR DE BIDONES DE LECHE

ESCALA:



CONJUNTO: PLACA F

1:1

CÓDIGO: EBL-001-001-005

PESO: 0.8N

DISEÑO: JUAN C.

28/05/23

HOJA

LARGO: 96mm

DIBUJÓ: JUAN C.

28/05/23

1/1

ANCHO: 40mm

REVISÓ: VICTOR E.

05/08/23

FICA

CIME

ALTO: 11mm

APROBÓ: VICTOR E.

05/08/23

1

2

3

4

A

B

C

D

E

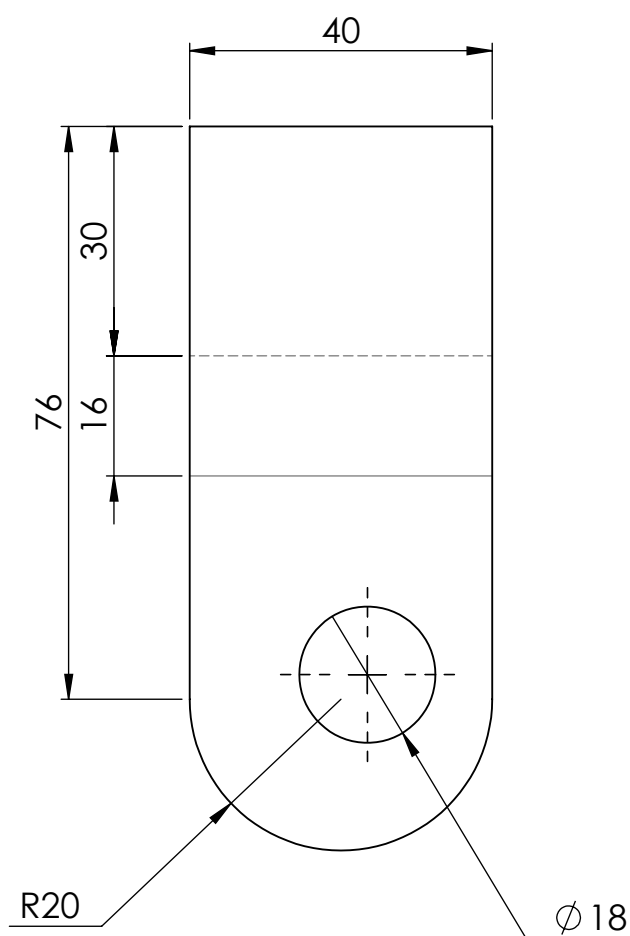
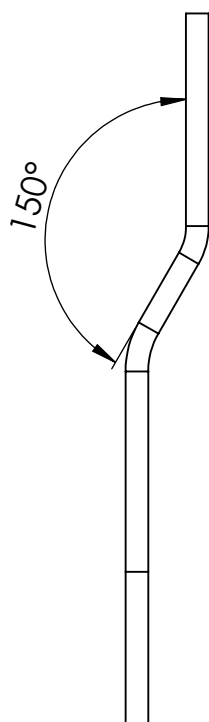
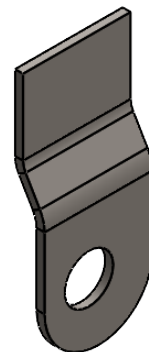

ESPESOR 3mm



PROYECTO: ELEVADOR DE BIDONES DE LECHE

ESCALA:



CONJUNTO: PLACA G

1:1

CÓDIGO: EBL-001-001-006

PESO: 0.8N

DISEÑO: JUAN C.

28/07/23

HOJA

LARGO: 96mm

DIBUJÓ: JUAN C.

28/07/23

1/1

ANCHO: 40mm

REVISÓ: VICTOR E.

05/08/23

FICA

CIME

ALTO: 11mm

APROBÓ: VICTOR E.

05/08/23

1

2

3

4

A

B

C

D

E

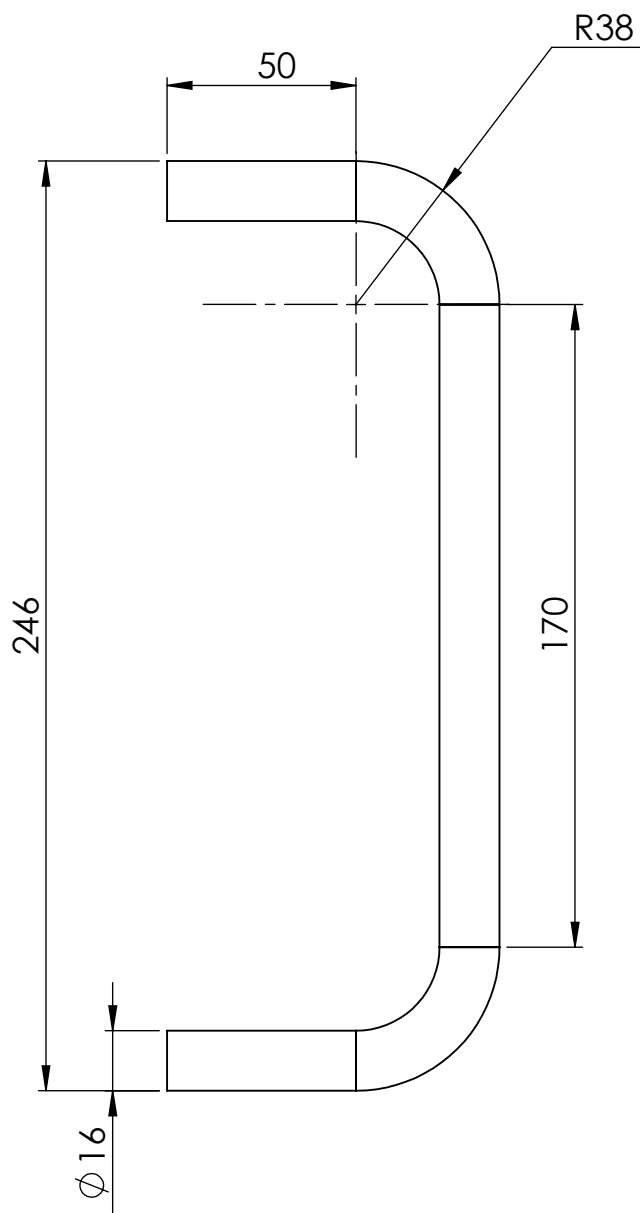

ESPESOR 1.1mm



PROYECTO: ELEVADOR DE BIDONES DE LECHE

ESCALA:



CONJUNTO: TUBO S

1:2

CÓDIGO: EBL-001-001-007

PESO: 1.4N

DISEÑO: JUAN C.

28/07/23

HOJA

LARGO: 246mm

DIBUJÓ: JUAN C.

28/07/23

ANCHO: 88mm

REVISÓ: VICTOR E.

05/08/23

1/1

FICA

CIME

ALTO: 16mm

APROBÓ: VICTOR E.

05/08/23

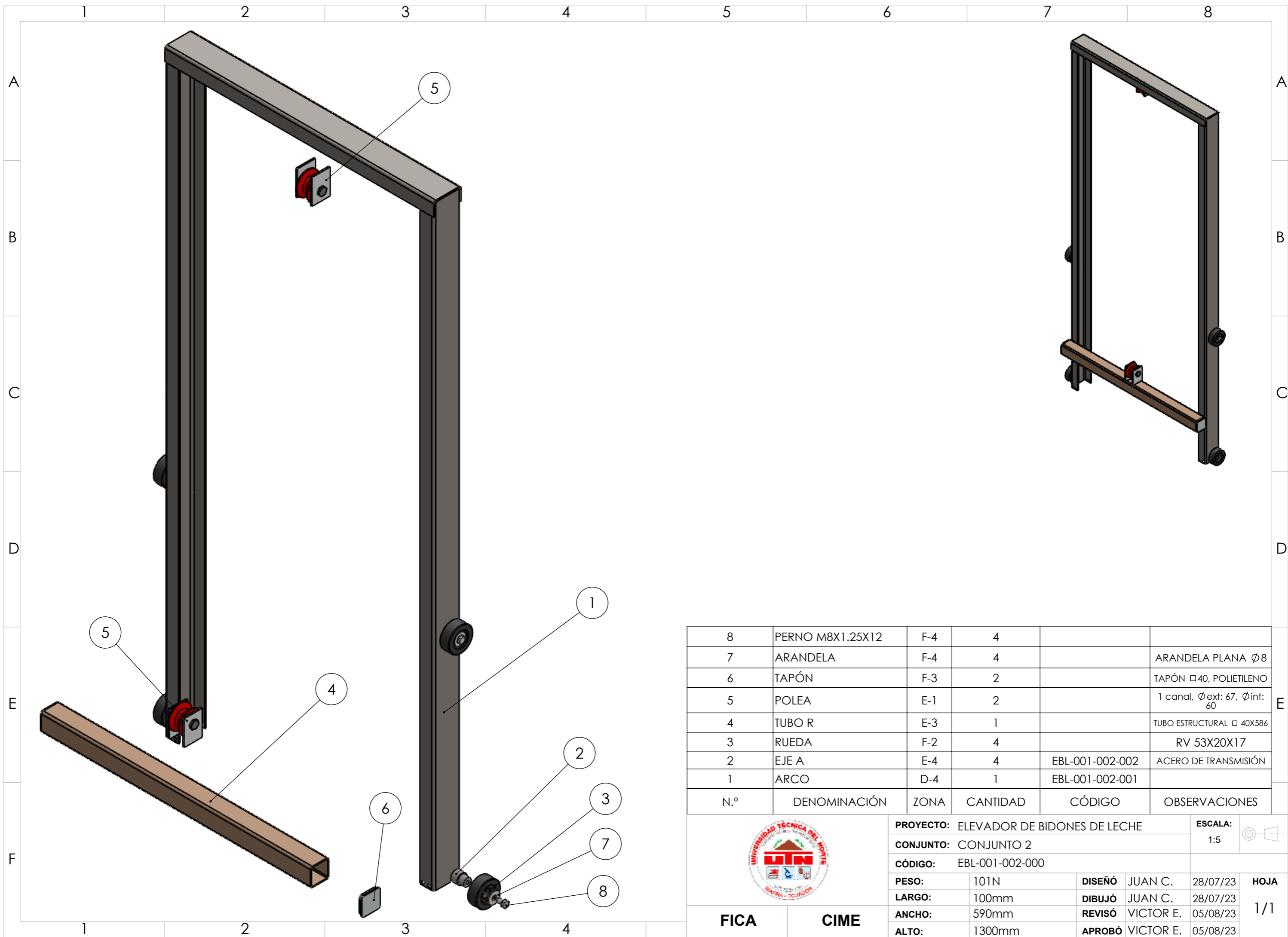

N.º	DENOMINACIÓN	ZONA	CANTIDAD	CÓDIGO	OBSERVACIONES
8	PERNO M8X1.25X12	F-4	4		
7	ARANDELA	F-4	4		ARANDELA PLANA Ø8
6	TAPÓN	F-3	2		TAPÓN □40, POLIETILENO
5	POLEA	E-1	2		1 canal, Øext: 67, Øint: 60
4	TUBO R	E-3	1		TUBO ESTRUCTURAL □ 40X586
3	RUEDA	F-2	4		RV 53X20X17
2	EJE A	E-4	4	EBL-001-002-002	ACERO DE TRANSMISIÓN
1	ARCO	D-4	1	EBL-001-002-001	



PROYECTO: ELEVADOR DE BIDONES DE LECHE				ESCALA: 1:5	
CONJUNTO: CONJUNTO 2					
CÓDIGO: EBL-001-002-000					
PESO:	101N	DISEÑO:	JUAN C.	28/07/23	HOJA 1/1
LARGO:	100mm	DIBUJÓ:	JUAN C.	28/07/23	
ANCHO:	590mm	REVISÓ:	VICTOR E.	05/08/23	
ALTO:	1300mm	APROBÓ:	VICTOR E.	05/08/23	

FICA **CIME**

1

2

3

4

A

B

C

D

E

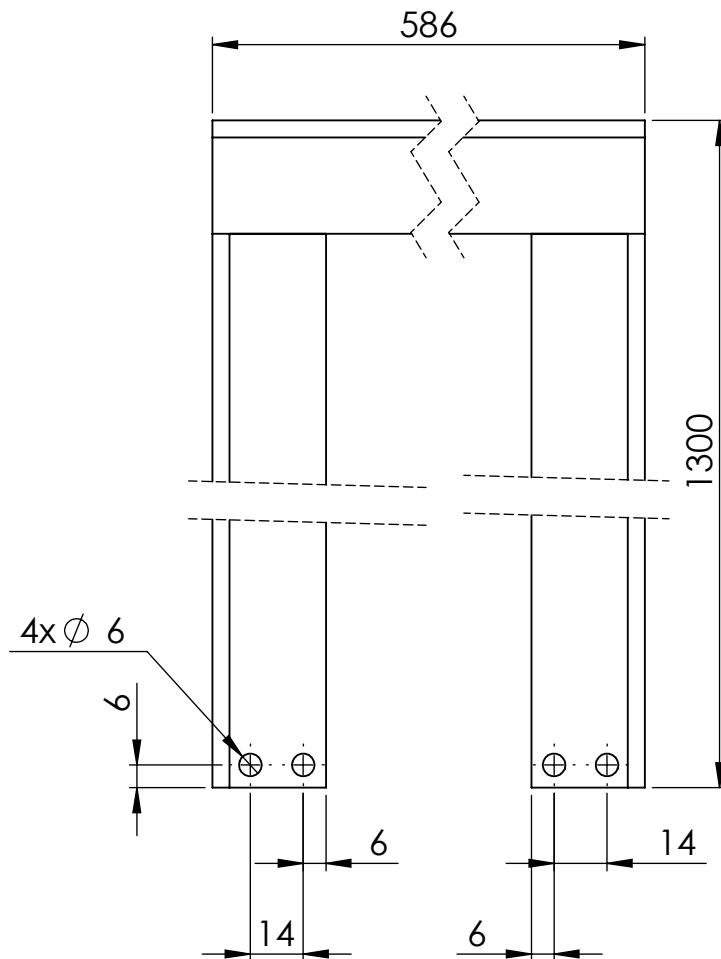

PERFIL TIPO U 60X30X3



PROYECTO: ELEVADOR DE BIDONES DE LECHE

ESCALA:



CONJUNTO: ARCO

1:2

CÓDIGO: EBL-001-002-001

PESO: 83N

DISEÑO

JUAN C.

28/07/23

HOJA

LARGO: 1300mm

DIBUJÓ

JUAN C.

28/07/23

1/1

ANCHO: 586mm

REVISÓ

VICTOR E.

05/08/23

FICA

CIME

ALTO: 60mm

APROBÓ

VICTOR E.

05/08/23

1

2

3

4

A

B

C

D

E

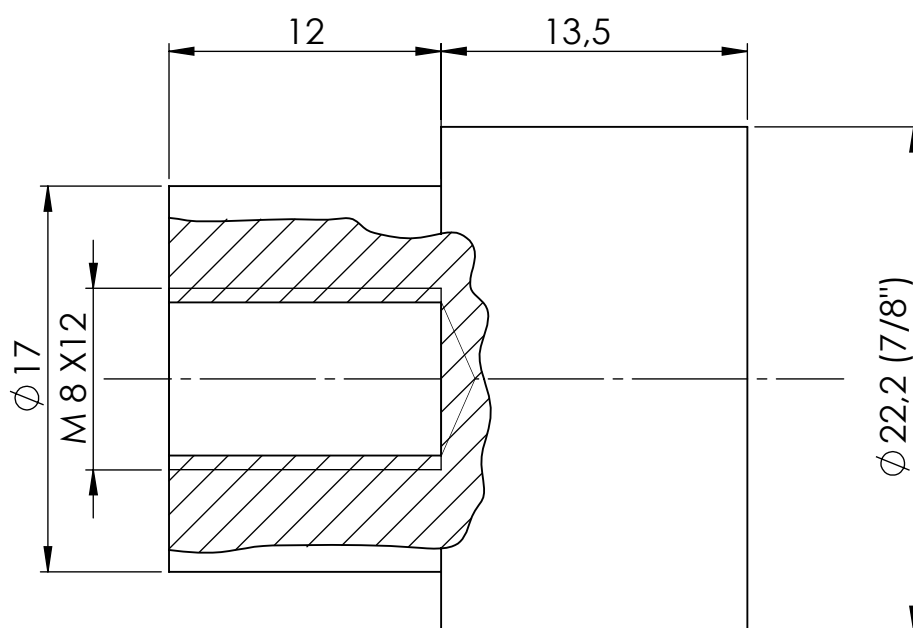

PROYECTO: ELEVADOR DE BIDONES DE LECHE

ESCALA:

3:1



CONJUNTO: EJE A

CÓDIGO: EBL-001-002-002

PESO: 0.6N

DISEÑO JUAN C.

28/05/23

LARGO: 25.5mm

DIBUJÓ JUAN C.

28/05/23

ANCHO: 22.2mm

REVISÓ VICTOR E.

05/08/23

ALTO: 22.2mm

APROBÓ VICTOR E.

05/08/23

FICA

CIME

HOJA

1/1

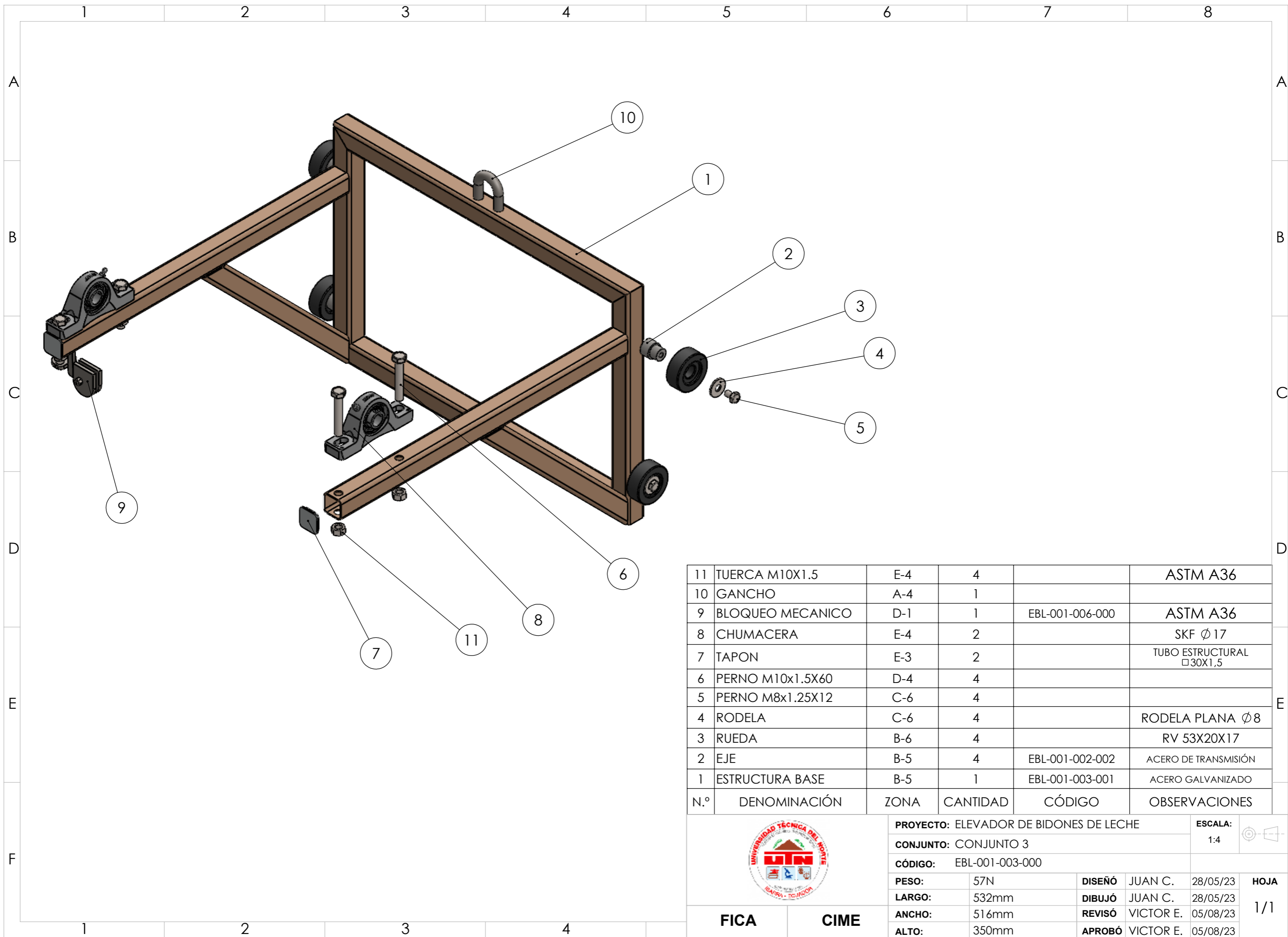

11	TUERCA M10X1.5	E-4	4		ASTM A36
10	GANCHO	A-4	1		
9	BLOQUEO MECANICO	D-1	1	EBL-001-006-000	ASTM A36
8	CHUMACERA	E-4	2		SKF ϕ 17
7	TAPON	E-3	2		TUBO ESTRUCTURAL \square 30X1,5
6	PERNO M10x1.5X60	D-4	4		
5	PERNO M8x1.25X12	C-6	4		
4	RODELA	C-6	4		RODELA PLANA ϕ 8
3	RUEDA	B-6	4		RV 53X20X17
2	EJE	B-5	4	EBL-001-002-002	ACERO DE TRANSMISIÓN
1	ESTRUCTURA BASE	B-5	1	EBL-001-003-001	ACERO GALVANIZADO
N.º	DENOMINACIÓN	ZONA	CANTIDAD	CÓDIGO	OBSERVACIONES



PROYECTO: ELEVADOR DE BIDONES DE LECHE				ESCALA: 1:4	
CONJUNTO: CONJUNTO 3					
CÓDIGO: EBL-001-003-000					
PESO:	57N	DISEÑO	JUAN C.	28/05/23	HOJA 1/1
LARGO:	532mm	DIBUJÓ	JUAN C.	28/05/23	
ANCHO:	516mm	REVISÓ	VICTOR E.	05/08/23	
ALTO:	350mm	APROBÓ	VICTOR E.	05/08/23	

FICA

CIME

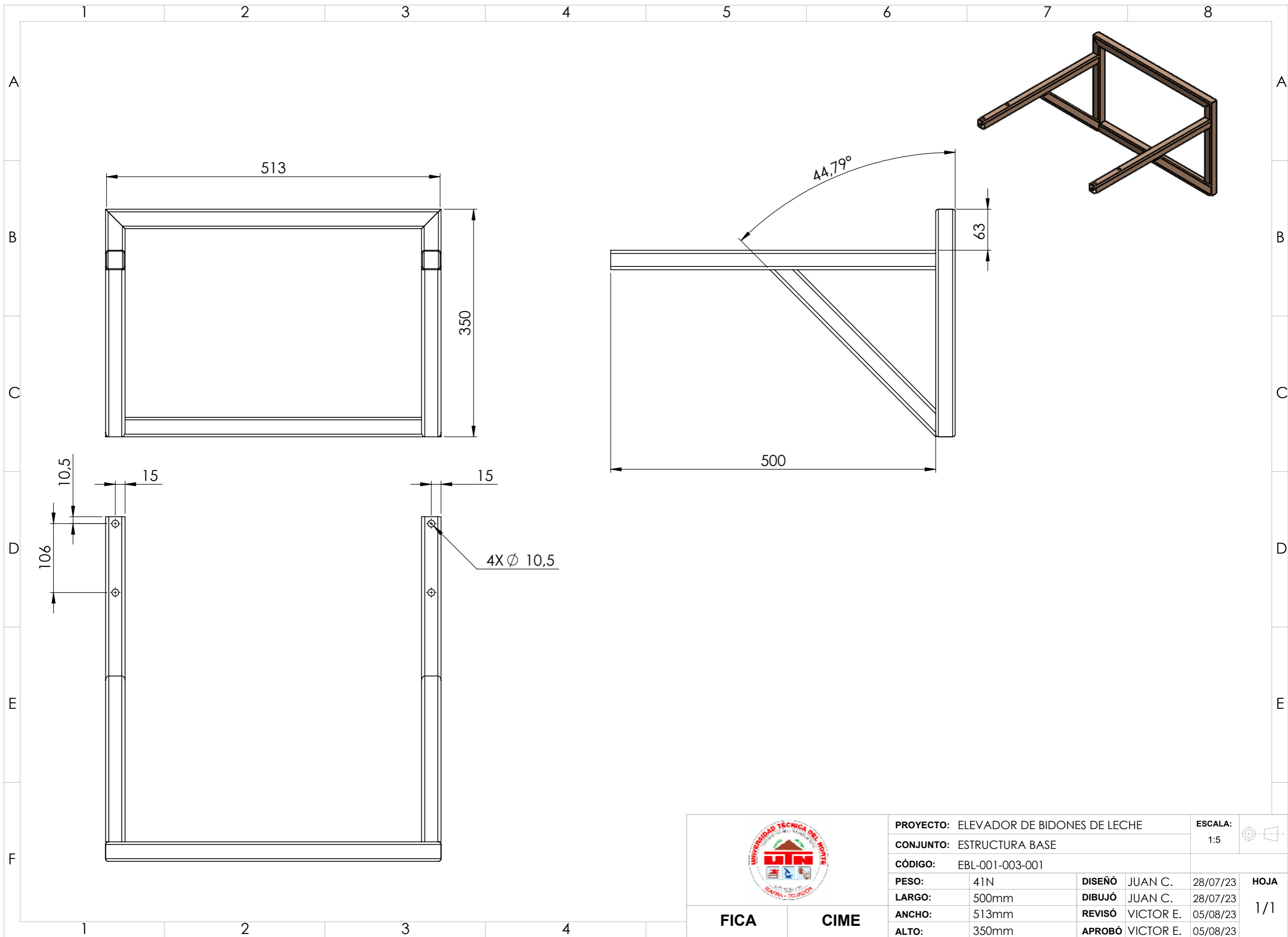

	PROYECTO: ELEVADOR DE BIDONES DE LECHE			ESCALA:	
	CONJUNTO: ESTRUCTURA BASE			1:5	
CÓDIGO: EBL-001-003-001					
PESO:	41N	DISEÑO	JUAN C.	28/07/23	HOJA 1/1
LARGO:	500mm	DIBUJÓ	JUAN C.	28/07/23	
ANCHO:	513mm	REVISÓ	VICTOR E.	05/08/23	
ALTO:	350mm	APROBÓ	VICTOR E.	05/08/23	
FICA	CIME				

1

2

3

4

A

B

C

D

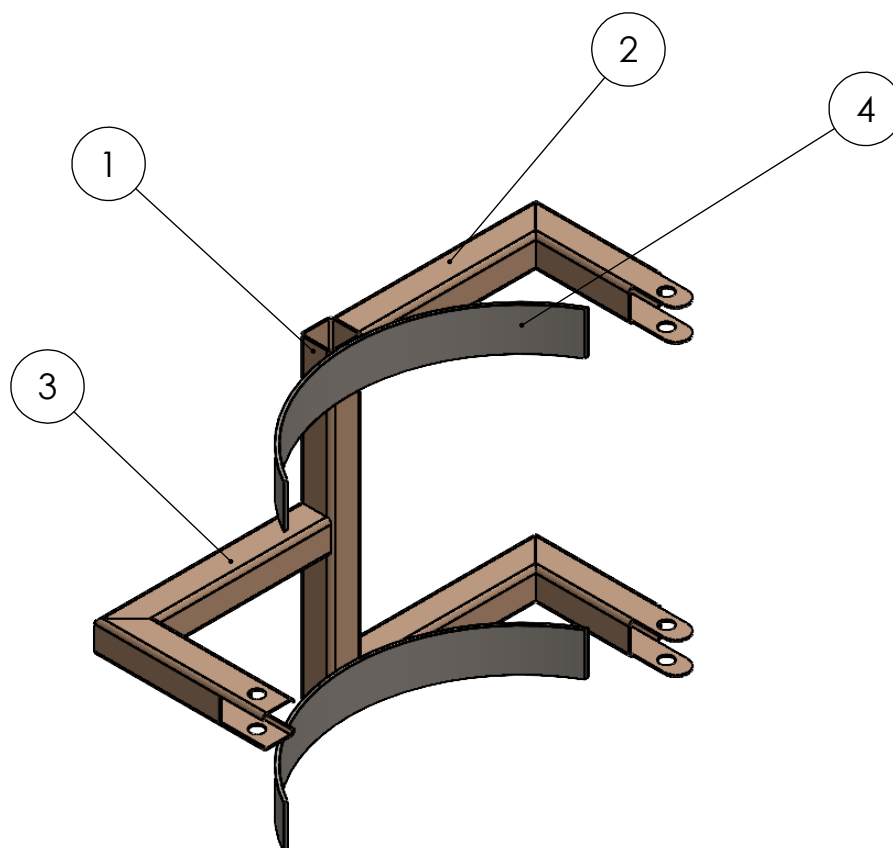

E

4	PLACA B	B-4	2	EBL-001-004-003	ASTM A36
3	TUBO P	C-1	1	EBL-001-004-002	TUBO ESTRUCTURAL □ 30X1.5
2	TUBO O	B-3	2	EBL-001-004-001	TUBO ESTRUCTURAL □ 30X1.5
1	TUBO M	B-1	1		TUBO ESTRUCTURAL □ 30X300X1.5
N.º	DENOMINACIÓN	ZONA	CANTIDAD	CÓDIGO	OBSERVACIÓN



PROYECTO: ELEVADOR DE BIDONES DE LECHE

ESCALA:

1:5



CONJUNTO: CONJUNTO 4

CÓDIGO: EBL-001-004-000

PESO: 21N

DISEÑO: JUAN C. 28/07/23

LARGO: 300mm

DIBUJÓ: JUAN C. 28/07/23

ANCHO: 412mm

REVISÓ: VICTOR E. 05/08/23

ALTO: 160mm

APROBÓ: VICTOR E. 05/08/23

FICA

CIME

1/1

1

2

3

4

A

B

C

D

E

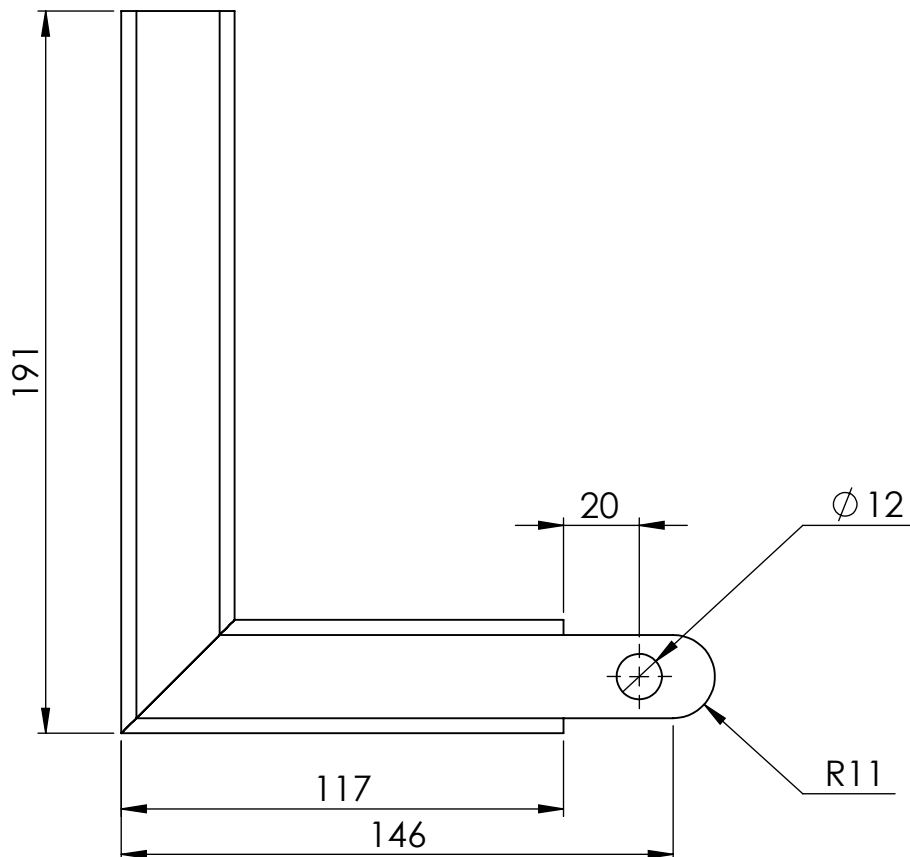

TUBO ESTRUCTURAL □ 30 ESPESOR 1,5 mm



PROYECTO: ELEVADOR DE BIDONES DE LECHE

ESCALA:



CONJUNTO: TUBO O

1:2

CÓDIGO: EBL-001-004-001

PESO: 3.6N

DISEÑO JUAN C. 28/07/23

LARGO: 191mm

DIBUJÓ JUAN C. 28/07/23

ANCHO: 146mm

REVISÓ VICTOR E. 05/08/23

ALTO: 30mm

APROBÓ VICTOR E. 05/08/23

FICA

CIME

HOJA

1/1

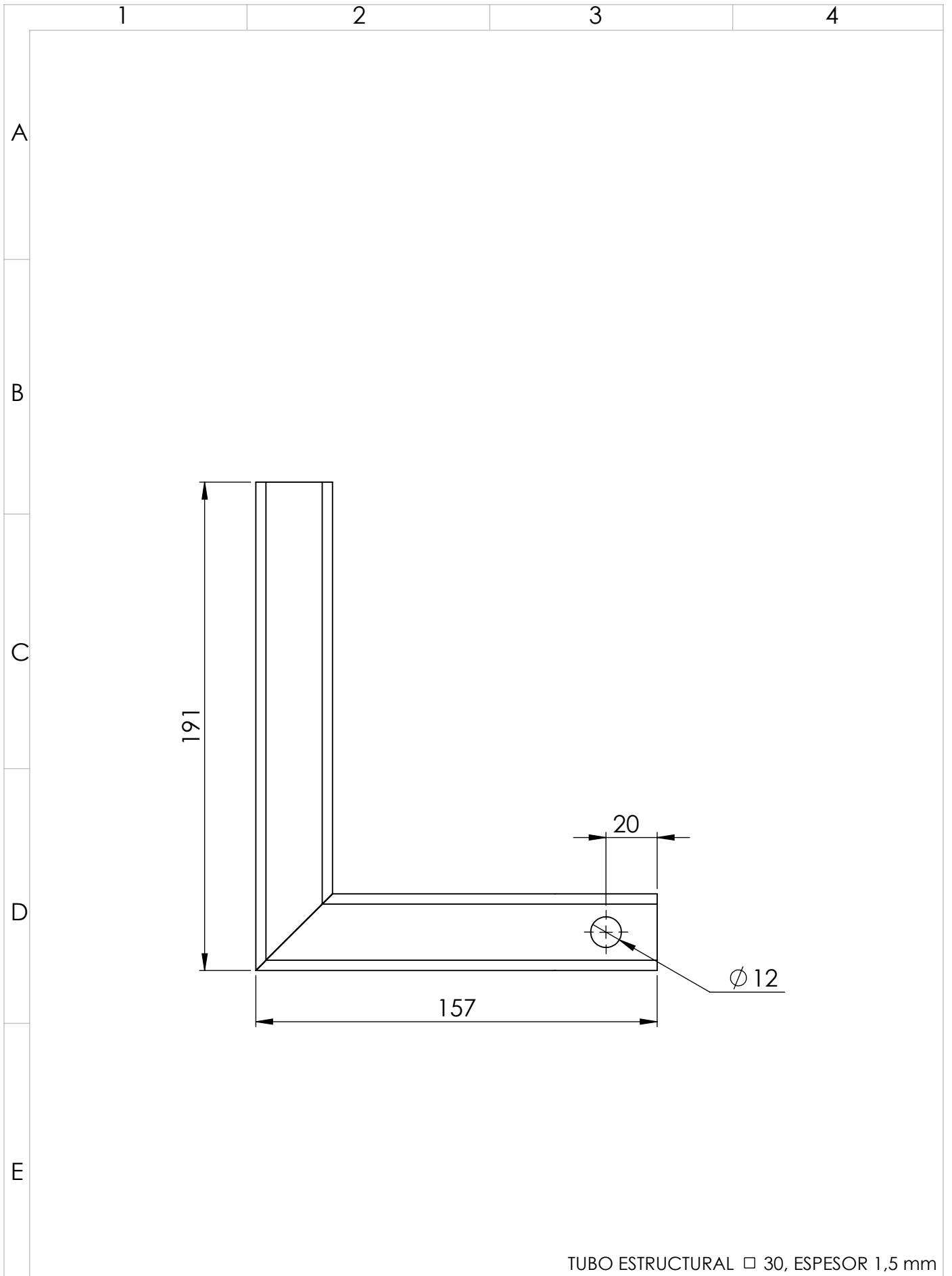

TUBO ESTRUCTURAL □ 30, ESPESOR 1,5 mm



PROYECTO: ELEVADOR DE BIDONES DE LECHE		ESCALA: 1:2			
CONJUNTO: TUBO P					
CÓDIGO: EBL-001-004-002					
PESO:	3.7N	DISEÑO	JUAN C.	28/07/23	HOJA 1/1
LARGO:	191mm	DIBUJÓ	JUAN C.	28/07/23	
ANCHO:	157mm	REVISÓ	VICTOR E.	05/08/23	
ALTO:	30mm	APROBÓ	VICTOR E.	05/08/23	

FICA

CIME

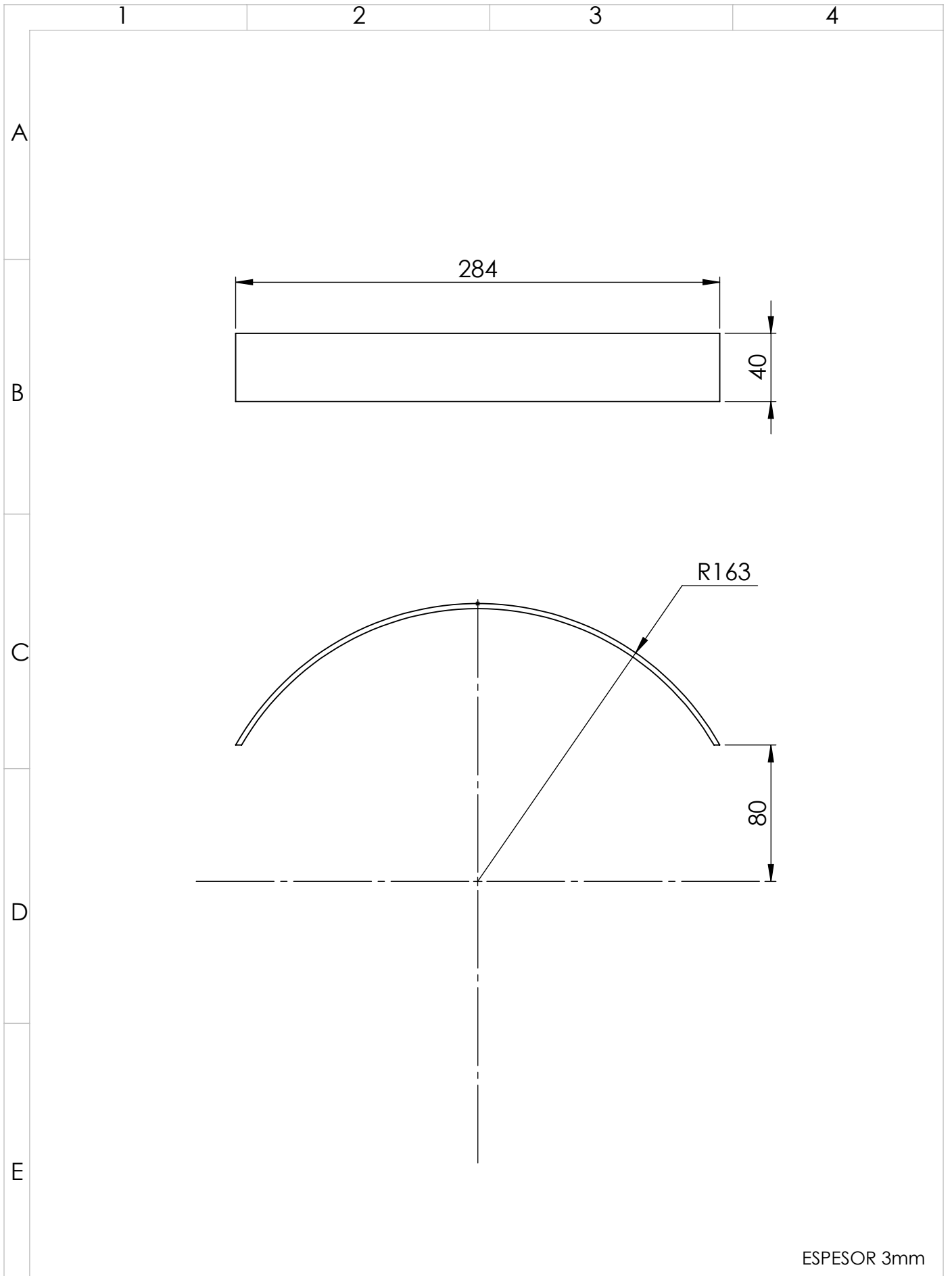

ESPESOR 3mm



PROYECTO: ELEVADOR DE BIDONES DE LECHE

ESCALA:



CONJUNTO: PLACA B

1:3

CÓDIGO: EBL-001-004-003

PESO: 3.1N

DISEÑO: JUAN C.

28/07/23

HOJA

LARGO: 284mm

DIBUJÓ: JUAN C.

28/07/23

1/1

ANCHO: 40mm

REVISÓ: VICTOR E.

05/08/23

FICA

CIME

ALTO: 83mm

APROBÓ: VICTOR E.

05/08/23

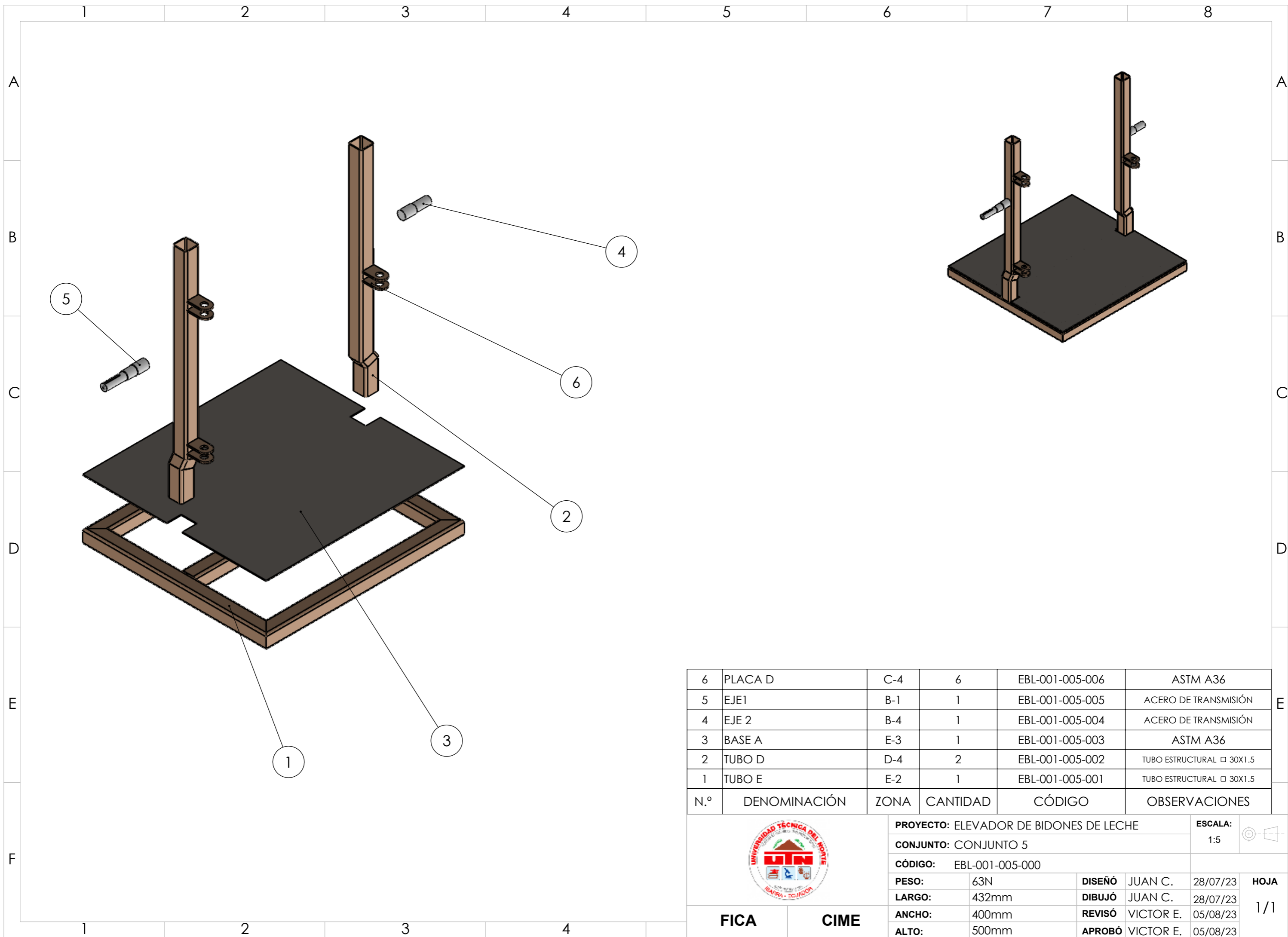

6	PLACA D	C-4	6	EBL-001-005-006	ASTM A36
5	EJE1	B-1	1	EBL-001-005-005	ACERO DE TRANSMISIÓN
4	EJE 2	B-4	1	EBL-001-005-004	ACERO DE TRANSMISIÓN
3	BASE A	E-3	1	EBL-001-005-003	ASTM A36
2	TUBO D	D-4	2	EBL-001-005-002	TUBO ESTRUCTURAL □ 30X1.5
1	TUBO E	E-2	1	EBL-001-005-001	TUBO ESTRUCTURAL □ 30X1.5
N.º	DENOMINACIÓN	ZONA	CANTIDAD	CÓDIGO	OBSERVACIONES



PROYECTO: ELEVADOR DE BIDONES DE LECHE				ESCALA: 1:5	
CONJUNTO: CONJUNTO 5					
CÓDIGO: EBL-001-005-000					
PESO:	63N	DISEÑO	JUAN C.	28/07/23	HOJA 1/1
LARGO:	432mm	DIBUJÓ	JUAN C.	28/07/23	
ANCHO:	400mm	REVISÓ	VICTOR E.	05/08/23	
ALTO:	500mm	APROBÓ	VICTOR E.	05/08/23	

FICA

CIME

1

2

3

4

A

B

C

D

E

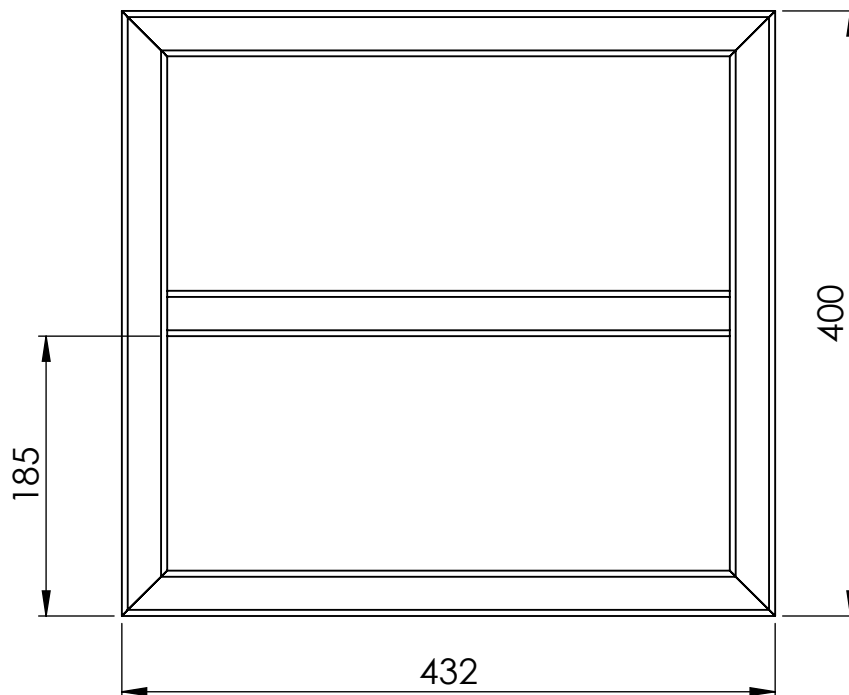

TUBO ESTRUCTURAL □ 30X1.5

**PROYECTO:** ELEVADOR DE BIDONES DE LECHE**ESCALA:****CONJUNTO:** TUBO E

1:5

CÓDIGO: EBL-001-005-001**PESO:** 24N**DISEÑO**

JUAN C.

28/07/23

HOJA**LARGO:** 432mm**DIBUJÓ**

JUAN C.

28/07/23

1/1

ANCHO: 400mm**REVISÓ**

VICTOR E.

05/08/23

FICA**CIME****ALTO:** 30mm**APROBÓ**

VICTOR E.

05/08/23

1

2

3

4

A

B

C

D

E

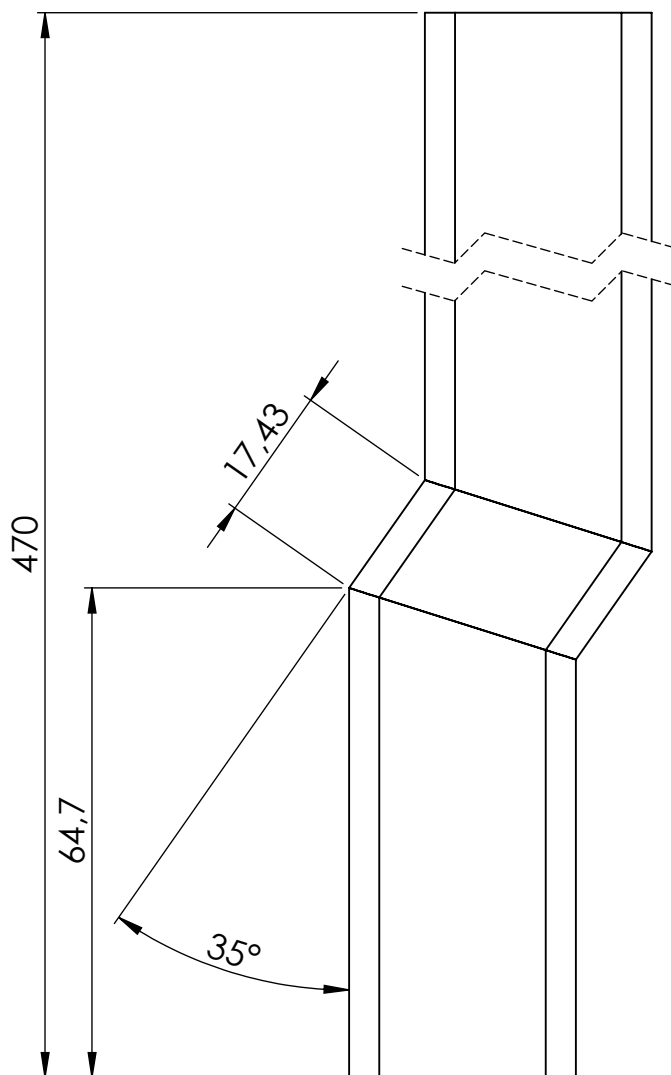

TUBO ESTRUCTURAL □ 30X1.5



PROYECTO: ELEVADOR DE BIDONES DE LECHE

ESCALA:



CONJUNTO: TUBO D

1:1

CÓDIGO: EBL-001-005-002

PESO: 6N

DISEÑO: JUAN C.

28/07/23

HOJA

LARGO: 470mm

DIBUJÓ: JUAN C.

28/07/23

ANCHO: 40mm

REVISÓ: VICTOR E.

05/08/23

1/1

FICA

CIME

ALTO: 30mm

APROBÓ: VICTOR E.

05/08/23

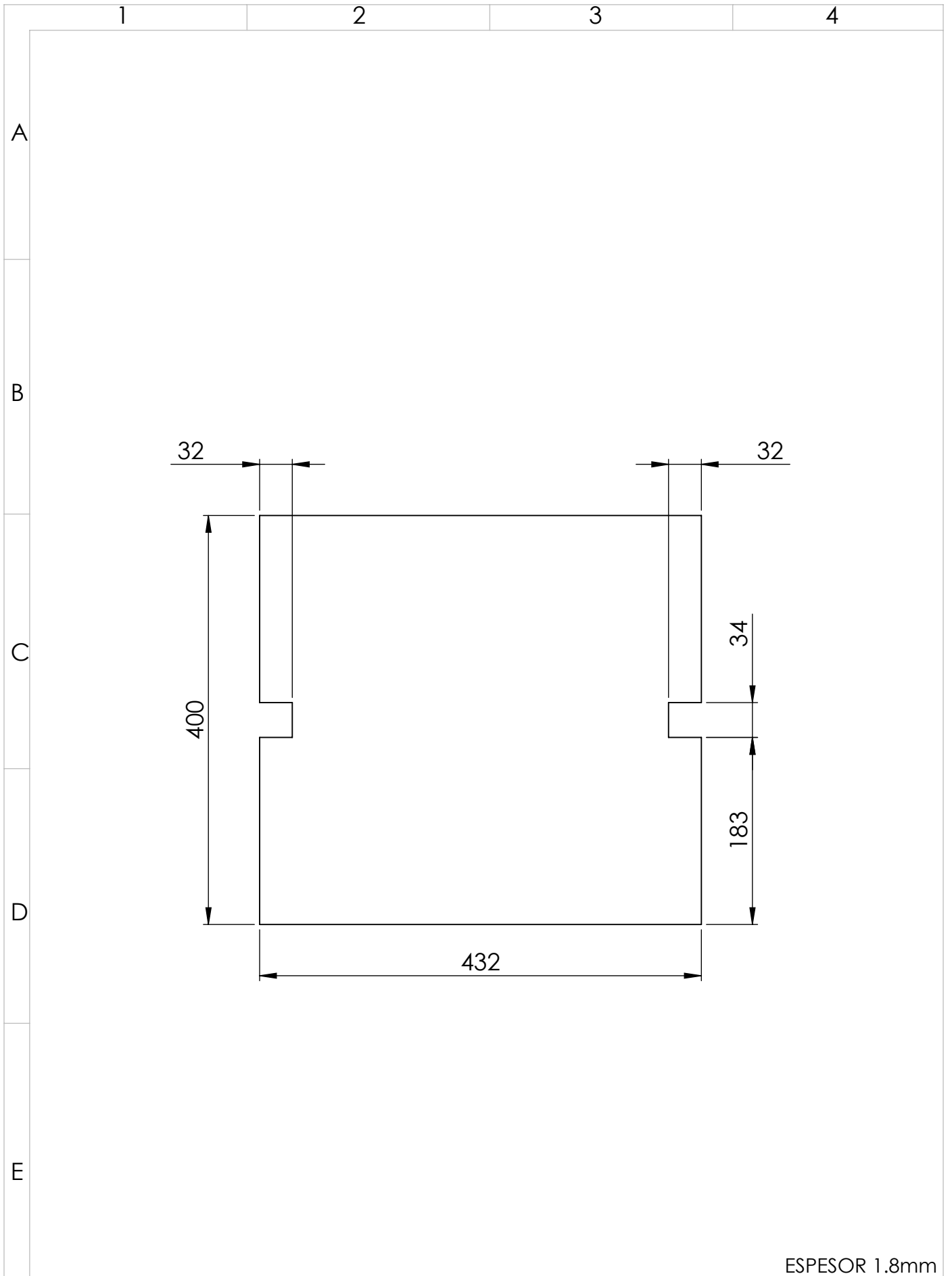

ESPESOR 1.8mm



PROYECTO: ELEVADOR DE BIDONES DE LECHE

ESCALA:

CONJUNTO: BASE A

1:5



CÓDIGO: EBL-001-005-003

PESO:	23.6N	DISEÑO	JUAN C.	28/07/23	HOJA 1/1
LARGO:	432mm	DIBUJÓ	JUAN C.	28/07/23	
ANCHO:	400mm	REVISÓ	VICTOR E.	05/08/23	
ALTO:	1.8mm	APROBÓ	VICTOR E.	05/08/23	

FICA

CIME

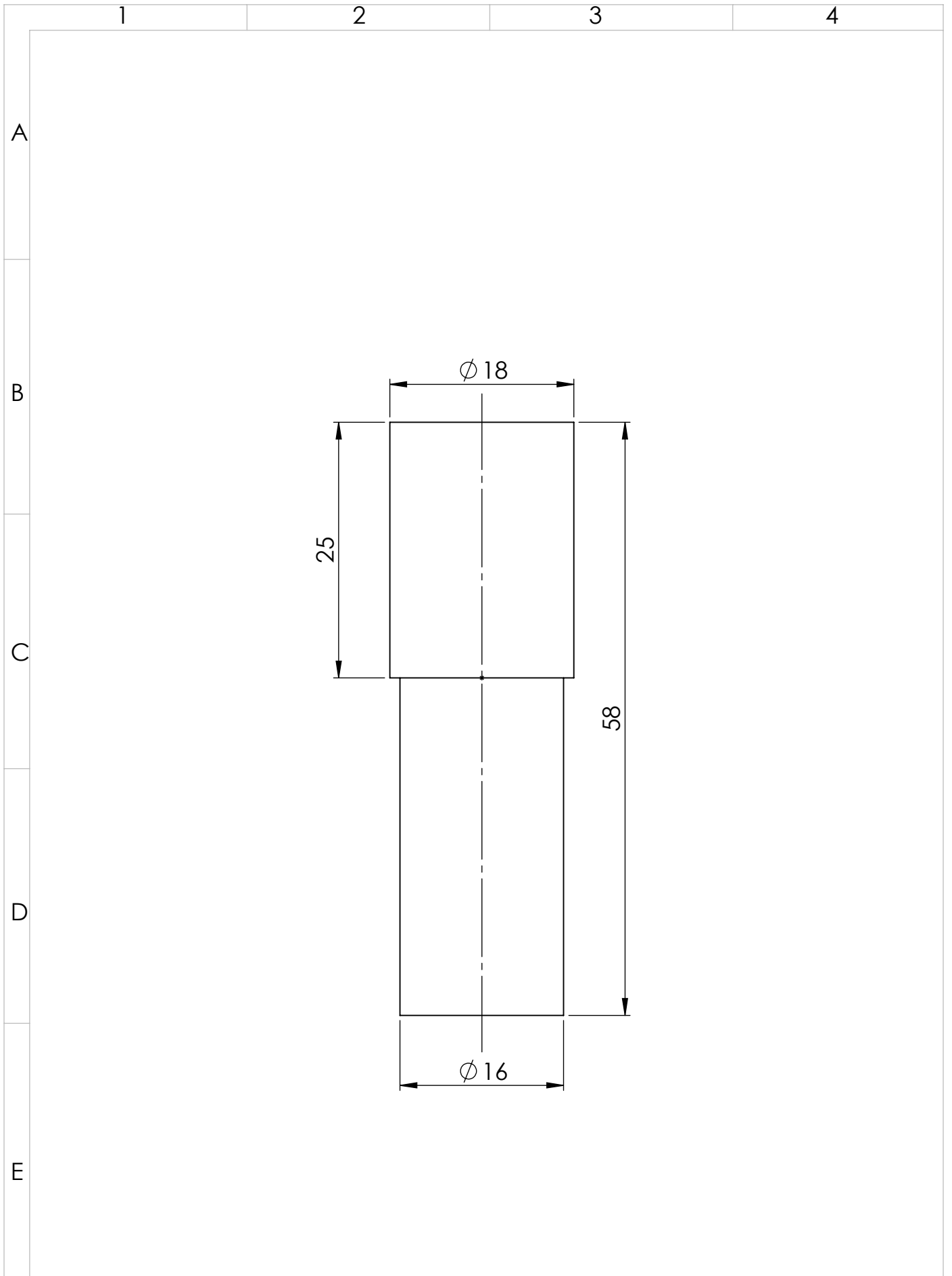

PROYECTO: ELEVADOR DE BIDONES DE LECHE

ESCALA:

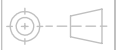

CONJUNTO: EJE 2

2:1

CÓDIGO: EBL-001-005-004

PESO: 1.6N

DISEÑO: JUAN C.

28/07/23

HOJA

LARGO: 58mm

DIBUJÓ: JUAN C.

28/07/23

1/1

ANCHO: 18mm

REVISÓ: VICTOR E.

05/08/23

ALTO: 18mm

APROBÓ: VICTOR E.

05/08/23

FICA

CIME

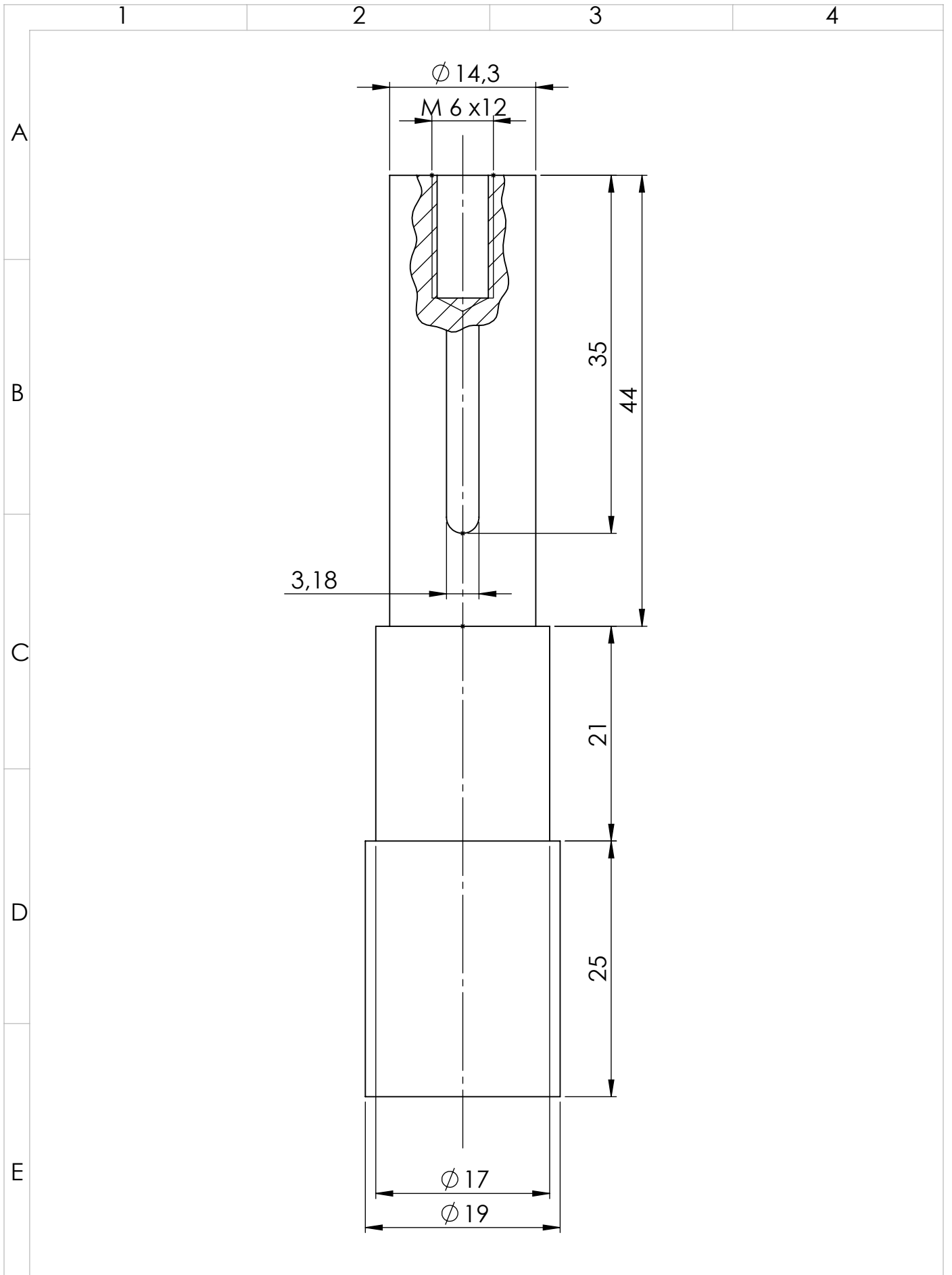

PROYECTO: ELEVADOR DE BIDONES DE LECHE

ESCALA:

CONJUNTO: EJE 1

2:1

CÓDIGO: EBL-001-005-005

PESO:

1.4N

DISEÑO

JUAN C.

28/07/23

LARGO:

90mm

DIBUJÓ

JUAN C.

28/07/23

ANCHO:

19mm

REVISÓ

VICTOR E.

05/08/23

ALTO:

19mm

APROBÓ

VICTOR E.

05/08/23

FICA

CIME



HOJA

1/1

1

2

3

4

A

B

C

D

E

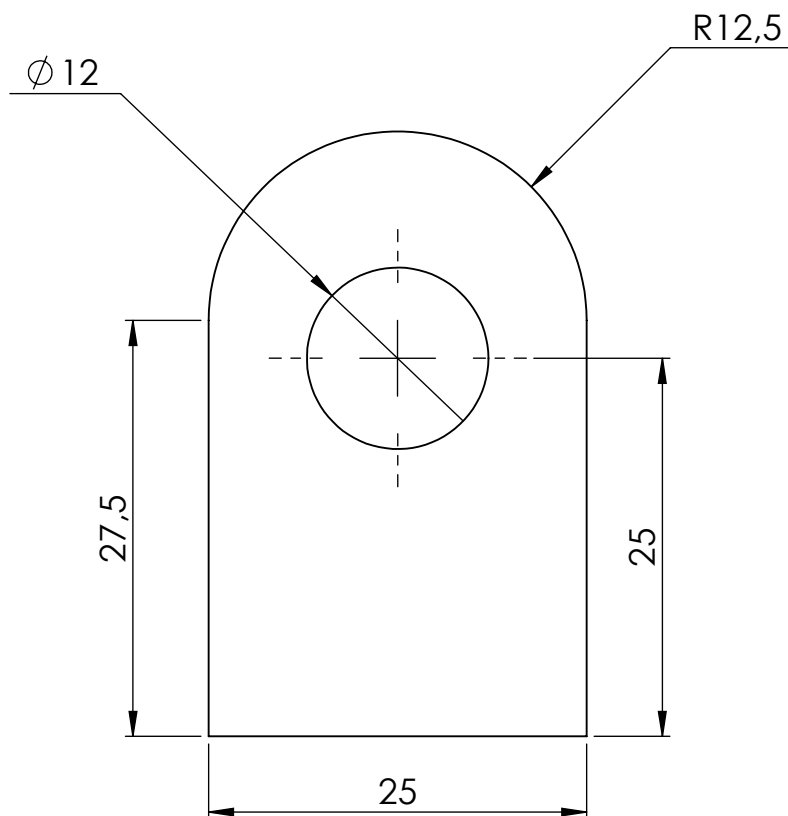

ESPESOR 3mm



PROYECTO: ELEVADOR DE BIDONES DE LECHE

ESCALA:

2:1



CONJUNTO: PLACA D

CÓDIGO: EBL-001-005-006

PESO: 0.2N

DISEÑO: JUAN C.

28/07/23

HOJA

LARGO: 40mm

DIBUJÓ: JUAN C.

28/07/23

ANCHO: 25mm

REVISÓ: VICTOR E.

05/08/23

1/1

FICA

CIME

ALTO: 3mm

APROBÓ: VICTOR E.

05/08/23

1

2

3

4

A

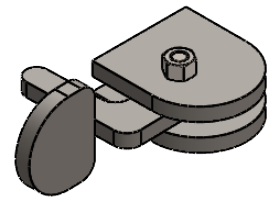

B

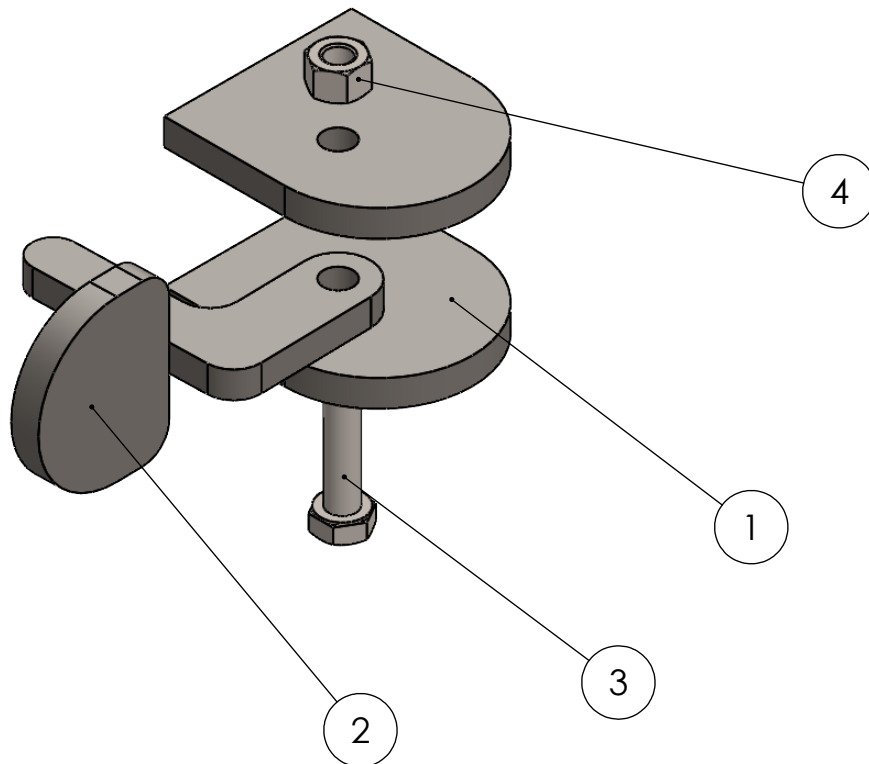

C

D

E

4	TUERCA M5X0.8	B-4	1		
3	PERNO M5X0.8X20	D-3	1		
2	PIEZA B	D-2	1	EBL-001-006-002	ASTM A36
1	PIEZA A	C-3	2	EBL-001-006-001	ASTM A36
N.º	DENOMINACIÓN	ZONA	CANTIDAD	CÓDIGO	OBSERVACIÓN



PROYECTO: ELEVADOR DE BIDONES DE LECHE

ESCALA:

1:1



CONJUNTO: BLOQUEO MECÁNICO

CÓDIGO: EBL-001-006-000

PESO:

1.43N

DISEÑO

JUAN C.

28/07/23

HOJA

LARGO:

74mm

DIBUJÓ

JUAN C.

28/07/23

1/1

ANCHO:

24mm

REVISÓ

VICTOR E.

05/08/23

ALTO:

40mm

APROBÓ

VICTOR E.

05/08/23

FICA

CIME

1

2

3

4

A

B

C

D

E

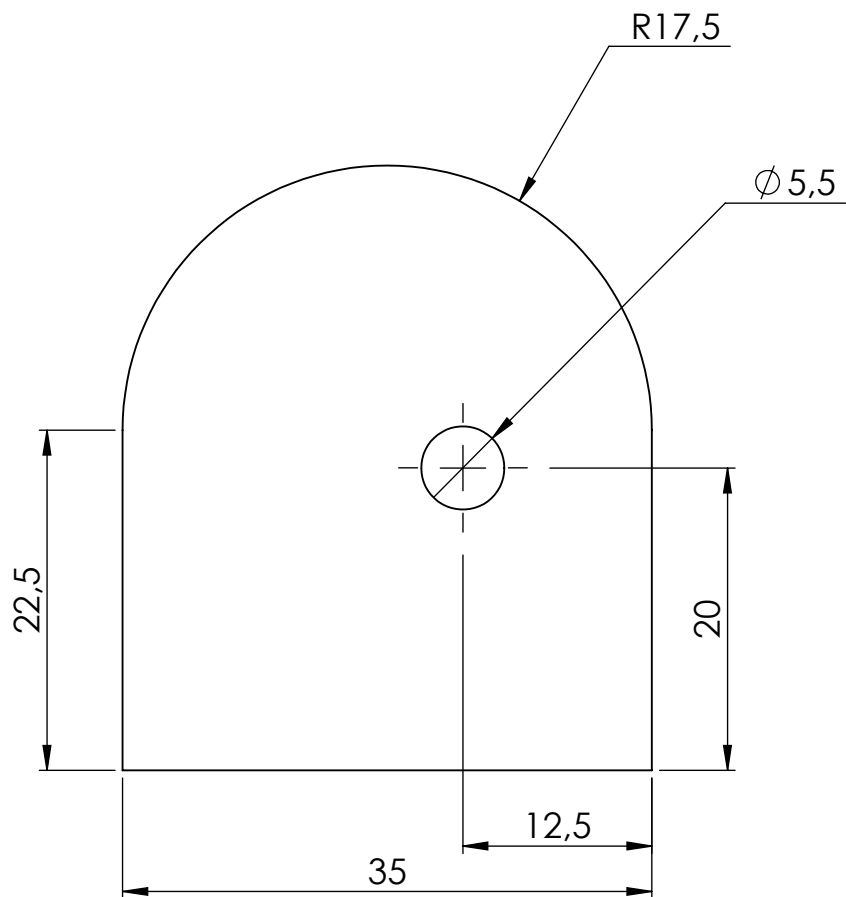

ESPESOR 5mm



PROYECTO: ELEVADOR DE BIDONES DE LECHE

ESCALA:



CONJUNTO: PIEZA A

2:1

CÓDIGO: EBL-001-006-001

PESO: 0.5N

DISEÑO

JUAN C.

28/05/23

HOJA

LARGO: 40mm

DIBUJÓ

JUAN C.

28/05/23

1/1

ANCHO: 35mm

REVISÓ

VICTOR E.

05/08/23

FICA

CIME

ALTO: 5mm

APROBÓ

VICTOR E.

05/08/23

1

2

3

4

A

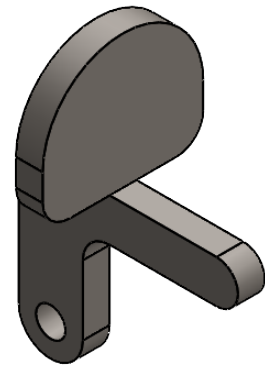

B

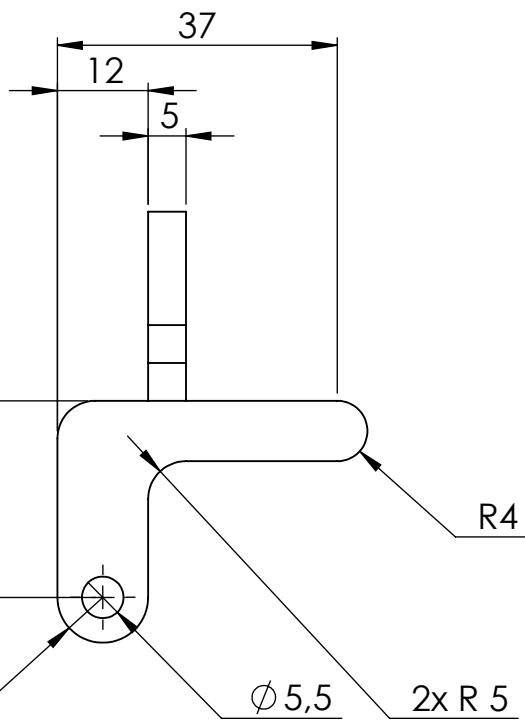

C

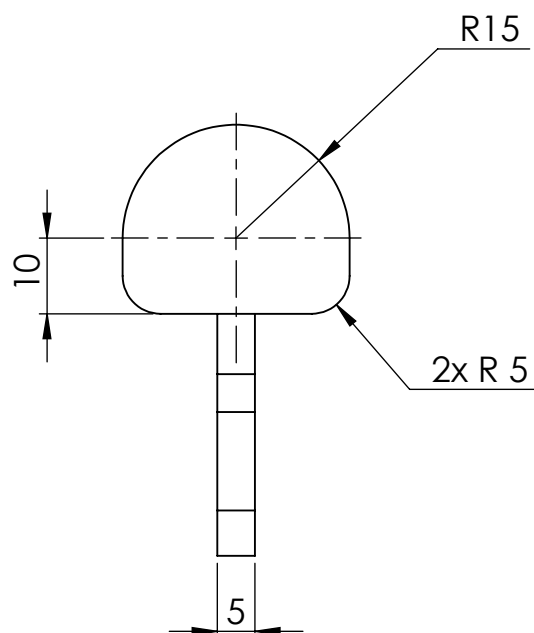

D

E



PROYECTO: ELEVADOR DE BIDONES DE LECHE

ESCALA:

CONJUNTO: PIEZA B

1:1

CÓDIGO: EBL-001-006-002

PESO: 0.5N

DISEÑO JUAN C.

28/07/23

LARGO: 37mm

DIBUJÓ JUAN C.

28/07/23

ANCHO: 30mm

REVISÓ VICTOR E.

05/08/23

ALTO: 57mm

APROBÓ VICTOR E.

05/08/23

FICA

CIME

HOJA

1/1

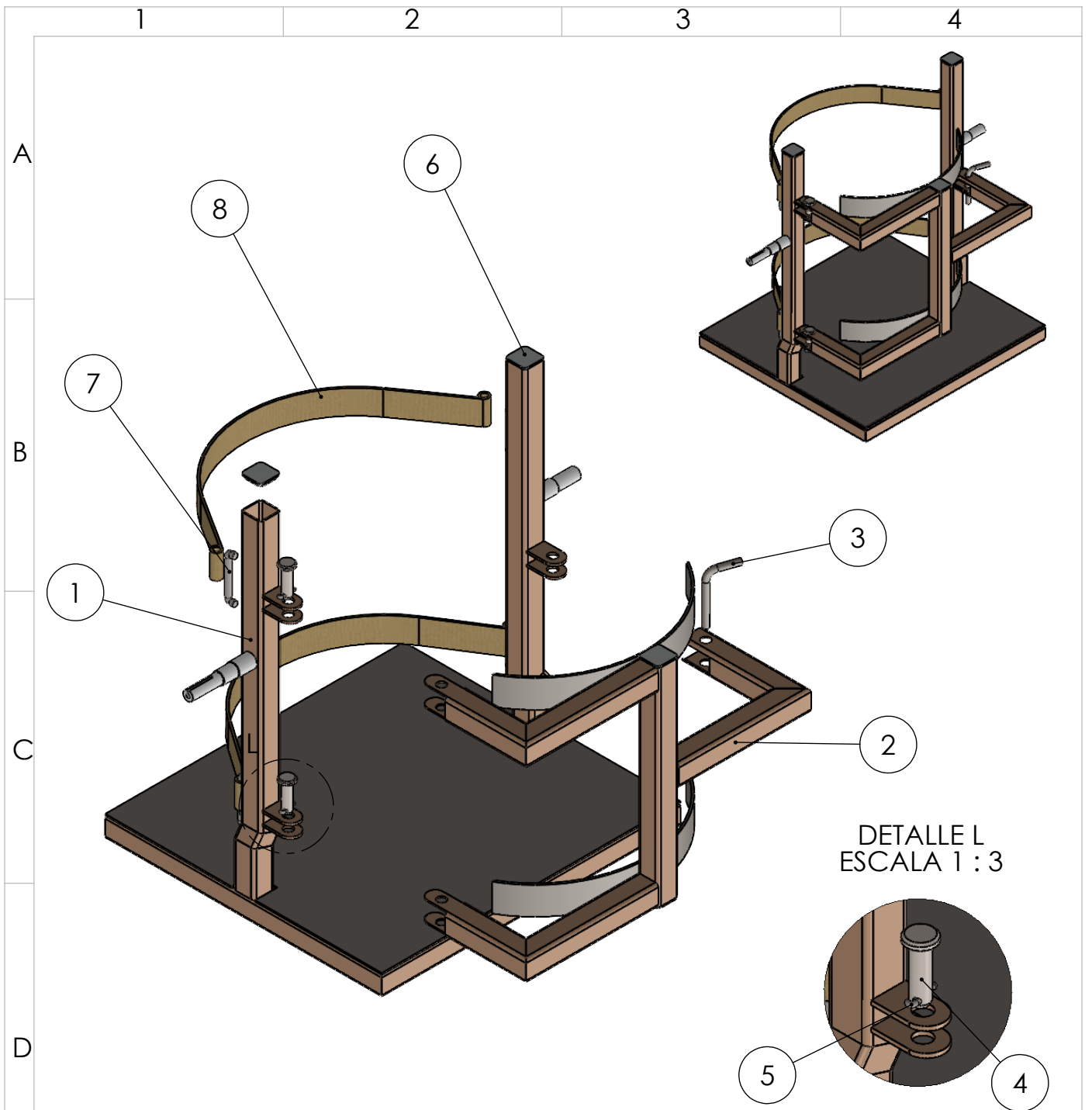

DETALLE L
ESCALA 1 : 3

8	CINTA DE AMARRE		2		ANCHO 50mm, CARGA 600-1200daN
7	GANCHO		4	EBL-001-007-002	
6	TAPON	E-3	4		TUBO CUADRADO ESTRUCTURAL □30X1.5
5	PIN 1		2		∅3.2
4	PASADOR 1		2		PASADOR CON HORQUILLA 12X40X3.2
3	PIN L		1	EBL-001-007-001	
2	SOPORTE		1	EBL-001-004-000	
1	ASIENTO		1	EBL-001-005-000	
N.º	DENOMINACIÓN	ZONA	CANTIDAD	CÓDIGO	OBSERVACIÓN



PROYECTO: ELEVADOR DE BIDONES DE LECHE

ESCALA:

CONJUNTO: CONJUNTO 7

1:6

CÓDIGO: EBL-001-007-000

PESO:

87.4N

DISEÑO

JUAN C.

28/07/23

HOJA

LARGO:

400mm

DIBUJÓ

JUAN C.

28/07/23

ANCHO:

432mm

REVISÓ

VICTOR E.

05/08/23

1/1

ALTO:

500mm

APROBÓ

VICTOR E.

05/08/23

FICA

CIME