



**UNIVERSIDAD TÉCNICA DEL NORTE**

**FACULTAD DE INGENIERÍA EN CIENCIAS APLICADAS**

**CARRERA DE INGENIERÍA EN MECATRÓNICA**

**“CARD OF CONDITIONING TO KNEE PROSTHESIS POWERED BY SIGNS  
ELECTROMYOGRAPHIC”**

**TECHNICAL REPORT**

**AUTHOR:**

Franklin Santiago Cadena Meneses

**DIRECTOR:**

Ing. Gabriela Verdezoto

**Ibarra – Ecuador**

**2015**

# CARD OF CONDITIONING TO KNEE PROSTHESIS POWERED BY SIGNS ELECTROMYOGRAPHIC

Franklin Santiago Cadena Meneses  
Carrera de Ingeniería en Mecatrónica, Universidad Técnica del Norte  
Ibarra, Ecuador

franklin.scm@gmail.com

**Abstract.** *The present work describes the development of a card to acquisition and conditioning of electromyographic (EMG) signals to control a knee prosthesis. The research aims to build an endogenous device easily accessible for people with physical disabilities, specifically in people with transfemoral amputations. Currently people with physical disabilities in their lower limbs have access to aesthetic prosthetics or other types medical accessories allowing mobility, however functionality of these is almost null or proves too uncomfortable, reason for which in the present work is pretended build a card to conditioning the myoelectric signals generated by the muscles to implement autonomous prosthetics directly controlled by the upper leg muscles. The electronics components implemented in the different circuits the stages of EMG signal conditioning were purchased locally and the design and simulation of circuits were performed in the software NI Multisim of National Instruments. The result of this work was the construction of a card conditioning EMG signals of low cost, with an output signal suitable for implement a prosthetic control system, activated by myoelectric pulses generated by muscle.*

**Keywords:** *Electromyography, knee prosthesis, acquisition, conditioning, circuits, myoelectric signal, muscles, muscle activity.*

## I. INTRODUCTION

The study of electromyography (EMG) is initially in the field of medicine, specifically in the treatment of muscle fatigue and diagnosis to neuromuscular diseases. However, several researchers have conducted a number of studies in order to exploit and interpret the myoelectric signals from the muscles to develop orthotics and prosthetics to improve the lifestyle of people. In Ecuador, according to the Ministerio de Salud [1] the number of amputations is alarming, as a result of several factors; among the main causes to amputations are car accidents and diabetes mellitus, despite the implementation of preventive measures and permanent campaigns conducted by several state organizations, these statistics continue to increase in our country [2].

The most common prosthesis developed in our country for different types of amputations in upper and lower limbs,

are prostheses passive (cosmetic or aesthetic) [2]. However these prosthesis cause problems mobility in people who use them, resulting in the long term not very functionals.

Therefore in this project it is proposed the construction of a card to acquisition and refurbishment of electromyographic signals to control a knee prosthesis (in transfemoral amputations), allowing the implementation of a myoelectric prosthesis (active or functional prosthesis).

## ELECTROMYOGRAPHY

Electromyography is the discipline that deals with the detection, analysis and use of electrical signal emitted by the muscles contracting. This signal is known as EMG.

The signal represent the current generated by the ion flux through the membrane of muscle fibers that propagates through the tissues involved to reach the detection surface of an electrode in the environment. This is a complex signal that is affected by the anatomical and physiological properties of muscles and the control scheme of the nervous system, and the characteristics of the instruments used for detection and analysis [3].

Features EMG signal.

- It is well established that the amplitude of the EMG signal is stochastic in nature (random) and can be represented reasonably by a Gaussian distribution function [4] [5].
- The amplitude of the signal can vary from a few [ $\mu$ V] to 10 [mV] (peak to peak) or from a few [ $\mu$ V] to 1,5 [mV] (rms) [4] [5].
- Usable energy of the signal is limited to the frequency range between 1 to 500 [Hz] [4] [5].
- The dominant energy of the EMG signal is in the range of 50 to 150[Hz] [4] [5].

An example of the frequency spectrum of the EMG signal depicted below (see Fig. 1):

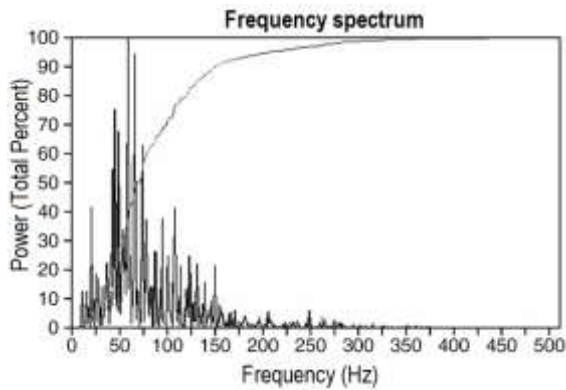

Fig. 1. Frequency spectrum of an electromyographic signal, obtained by the Fourier transform. [4].

## ELECTRODOS

The measurements of biopotentials are made using different types of specialized electrodes. The function of the electrodes is to coupling the ionic potential generated within the muscle to an electronic instrument [6]. The main types of electrodes used to detect the EMG signal are: non invasive (skin surface) and invasive (wire or needle) [3].

For the development of this project were used non-invasive electrodes with the following characteristics:

- The material is silver (Ag) and silver (AgCl) chloride containing a conductive paste or gel between the electrode and skin that adhere to the skin (see Fig. 2).

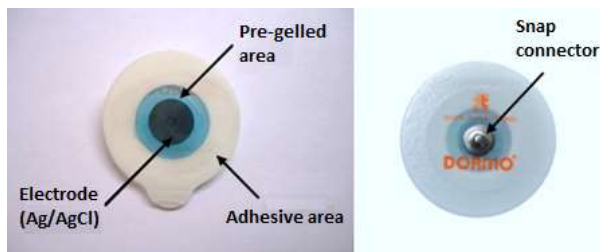

Fig. 2. Electrode structure.

- The shape of the electrodes according to the SENIAM (Surface Electromyography for the Non-Invasive Assessment of Muscles) recommend circular electrodes for records of surface electromyography (SEMG).
- El The size of the electrodes according to the SENIAM for use in SEMG can oscillate from a surface  $1[\text{mm}^2]$  up to a diameter of several [cm]. An European inventory showed who prefer circular electrodes with a diameter of 10 [mm] or an area of  $1[\text{cm}^2]$ .
- The inter-electrode distance (see Fig. 3) recommended by the SENIAM for bipolar electrodes is  $2[\text{cm}]$  [7].

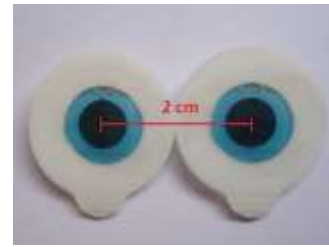

Fig. 3. Inter-electrode distance.

Considerations to take into account in the placement of surface electrodes:

- The shape and size of EMG signal depends of electrical property of the electrodes and the location registration.
- Proper preparation of the skin (non invasive recordings) consists of cleaning the skin with alcohol or the application of a small amount of electrolyte paste, as it helps to minimize the impedance of the skin-electrode interface and improve recorded signal quality [6].
- The chemical imbalance in the electrolyte / metal bonding, may vary with temperature fluctuations, the accumulation of perspiration, changes in the electrolyte concentration of the paste or gel, the relative movement of metal and skin, as well as amount of current flowing into the electrode [3].

## II. DESIGN OF STAGES OF ACQUISITION AND CONDITIONING

For acquiring myoelectric signals is necessary transmitted the signals from electrodes to an instrumentation amplifier, for this it is used a special cable with appropriate connectors at its two ends (see Fig. 4).



Fig. 4. Cable for SEMG electrodes.

The myoelectric signal conditioning consists of several stages: pre amplification, filtering, amplification, rectified and envelope detector.

### PRE AMPLIFICACIÓN

In the pre-amplification an instrumentation amplifier AD620 was used, the function of this amplifier is to detect the signals generated by muscle contractions and amplifying said signal to appropriate levels for filtering.

Typical features of an instrumentation amplifier for EMG are:

- Input impedance: as large as possible (usually  $> 10^{12}[\Omega]$  in parallel with a capacitance  $< 7$  [pF]).
- Common Mode Rejection Ratio (CMRR):  $> 85$  [dB].
- Input bias current: as low as possible (usually  $< 50$  [pA]).
- Noise  $< 5$  [ $\mu$ V] rms.
- Bandwidth (-3 [dB] in corner frequency, 12 [dB] / octave or higher attenuation) [8].

The gain  $G = 124$  used in the instrumentation amplifier (see Fig. 5) was determined using the equation proportioned by the manufacturer [9].

$$G = \frac{49.4k\Omega}{R_G} + 1$$

Equation 1. Instrumentation amplifier gain (AD620) [9].

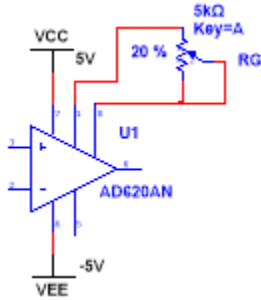

Fig. 5. Instrumentation amplifier gain.

In the differential inputs of instrumentation amplifier AD620 were implemented voltage followers with the integrated LM324N, in order to couple the input impedance and gain greater accuracy in signal inputs of the electrodes (see Fig. 6).

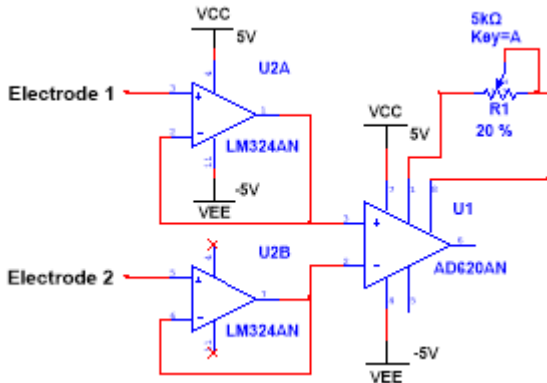

Fig. 6. Seguidores de voltaje.

Additional to the pre-amplification circuit it was designed a protection circuit known as right leg circuit (see Fig. 7). This feedback circuit, besides avoiding unbalanced currents and offset problems common mode noise in the

inputs differential of instrumentation amplifier, protects the patient from electrical damage.

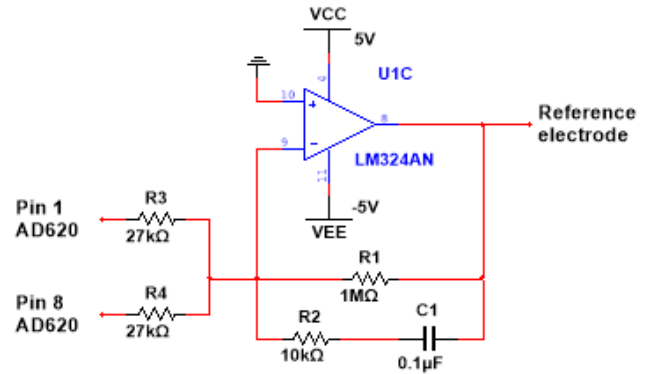

Fig. 7. Right leg circuit.

At the output of the instrumentation amplifier was designed an integrator circuit (see Fig. 8) to minimize the offset voltage at the output of the instrumentation amplifier and prevent the device from going into saturation.

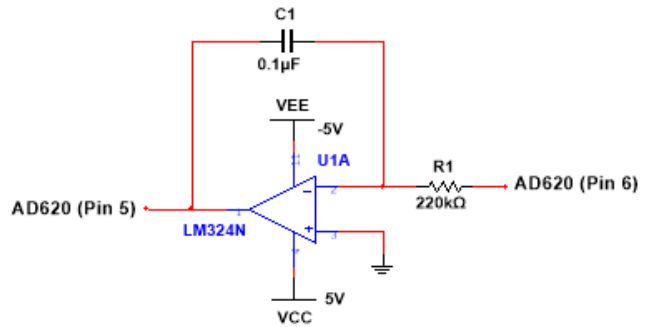

Fig. 8. Integrator circuit.

Finally in stage of pre-amplification was implemented an amplifier circuit in non inverting configuration with a gain of 11 to increase the signal amplitude (see Fig. 9).

$$G = 1 + \frac{R_f}{R}$$

Equation 2. Non-inverting amplifier gain.

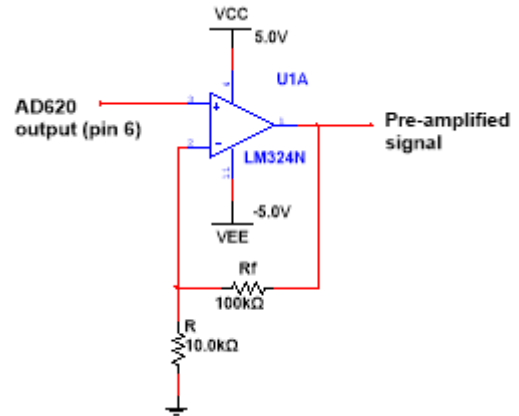

Fig. 9. Non-inverting amplifier.

## FILTERED

In the design of filters to obtain a signal with a low noise and eliminate or attenuate unwanted frequencies in the signal acquisition it is necessary to consider certain characteristics of the EMG signal filtering:

1. The filtering characteristic of the muscle tissues is a function of the distance between active muscle fibers and the detection surface of the electrode.
2. The noise generated by signals from "AC sources" (for example: frequencies of 50 or 60 [Hz], electromagnetic signals that radiate of power cables, sockets and electrical devices) and "DC noise" of signals (for example: polarization potential at the metal-electrolyte junction) with similar amplitudes detected in both sensing surfaces [3].
3. The movement between the detection surface of the electrode and the skin, as well as the movement of the cable connecting the electrodes to the amplifier, generate electrical signals with dominant energy between frequencies of 1 to 20 [Hz]. Due to the unstable nature of these signal components, should be considered as unwanted noise and removed of the signal.
4. The signal-noise ratio can be increased by filtering between 20 to 500 [Hz] with a minimum attenuation of 12 [dB] / octave (strict design features could be considered 400 [Hz] as the higher bandwidth of court. The value 500 [Hz] allows a safety margin in the circuit design) [4].

In considering the characteristics of a myoelectric signal and based on the experimental tests with filters of different orders, for design the circuit, was selected a bandpass filter 20 to 500 [Hz] of fourth order of type Butterworth in sallen key configuration, by good performance at low frequencies and present a maximally flat pass band (ver Fig. 10).

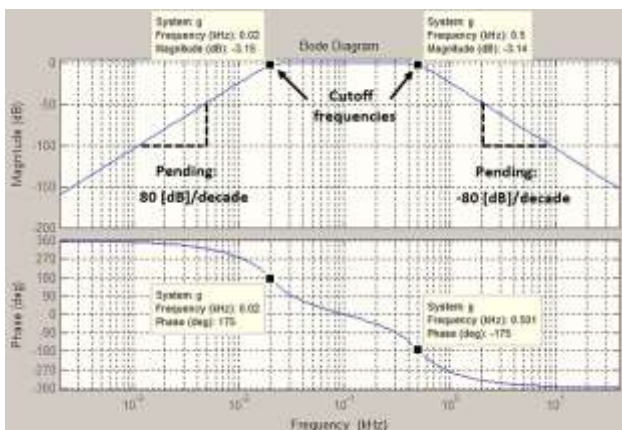

Fig. 10. Bode diagrams of the bandpass filter fourth order Butterworth of 20 to 500 [Hz] in sallen key configuration.

The bandpass filter fourth order is designed cascading, from the union in series of high pass filter to fourth order of 20 [Hz] (see Fig. 11) and a low pass filter to fourth order 500 [Hz] (see Fig. 12).

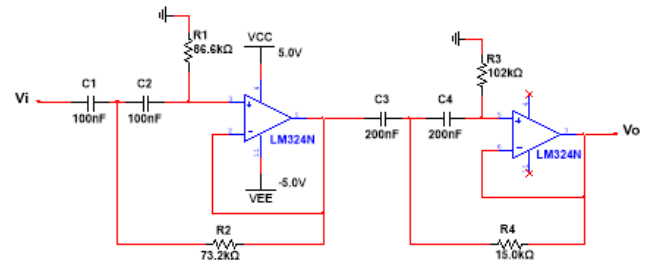

Fig. 11. Butterworth high-pass filter fourth order of 20 [Hz].

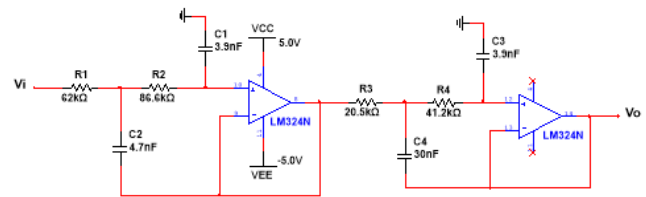

Fig. 12. Butterworth low-pass filter fourth order of 500 [Hz].

To filter the noise generated by signals from "AC sources", it was designed a notch filter or band suppressor of 60 [Hz] narrow band (see Fig. 13).

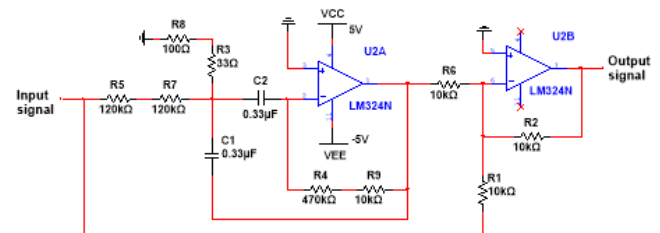

Fig. 13. Notch filter 60[Hz].

## AMPLIFICATION

For the final amplification stage circuit was designed an amplifier in non inverting configuration (see Fig. 14), with a gain of  $G = 20$ , this value is determined based on various experimental tests, because the amplitude of the myoelectric signal filtered have levels low voltage, is necessary to increase the amplitude of the signal to higher levels, so that state changes are evident in the output signal of the card when performing voluntary muscle contractions.

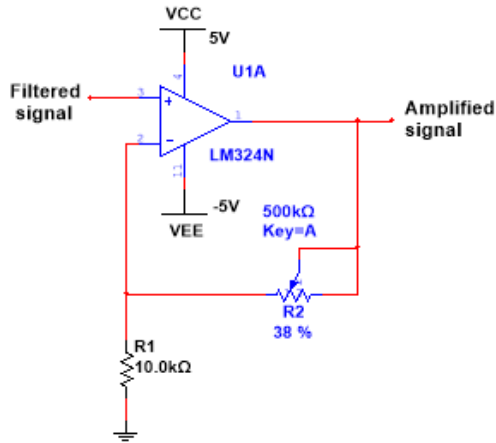

Fig. 14. Final amplification.

### RECTIFIED

For this project, will be used a full wave rectifier precision (see Fig. 15). That is, the two half cycles of an alternating voltage are transmitted, but turning them a single polarity circuit output. With a full wave rectifier precision, are rectified input voltages with amplitudes in the range of millivolts.

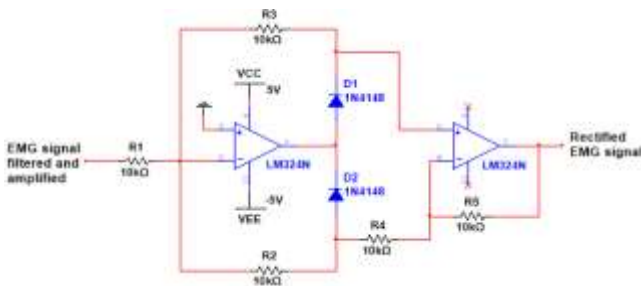

Fig. 15. Rectifier circuit.

### ENVELOPE DETECTOR

This circuit detects the peaks of the rectified signal (see Fig. 16), for which the capacitor stores a voltage equal to the positive peak of the input, while the discharge resistor causes the circuit detected reductions in the magnitude of the positive peak [10].

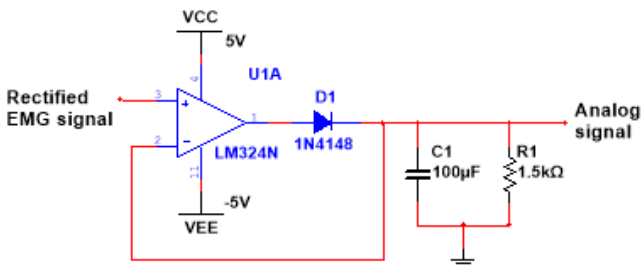

Fig. 16. Envelope detector circuit.

### III. EXPERIMENTAL TESTS AND RESULTS

For the performed tests the acquisition of EMG signals of the main quadriceps muscles was performed (see Fig. 17) and hamstrings (see Fig. 18). The location and orientation of the electrodes in the muscles and the reference electrode (see Fig. 19) were performed following the recommendations developed by the SENIAM.



Fig. 17. Main quadriceps muscles.

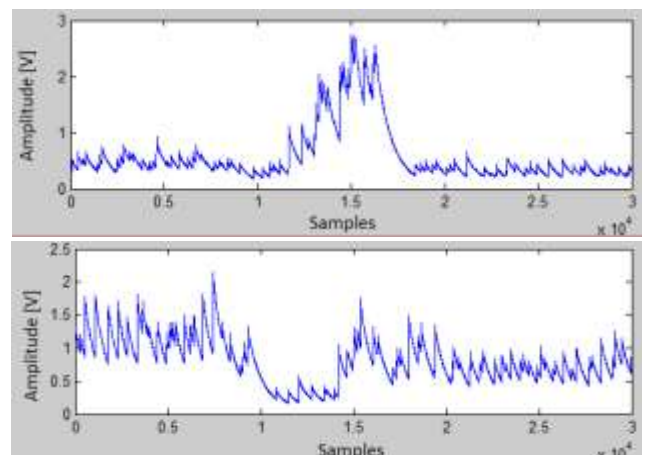

Fig. 18. Main hamstring muscles.



Fig. 19. Reference electrode.

Were performed 5 records (see Fig. 20) for each muscle, was performed an average the maximum amplitude and minimum amplitude of the signal and determining the muscle that present better characteristics to a voluntary muscle contraction during a normal gait cycle.



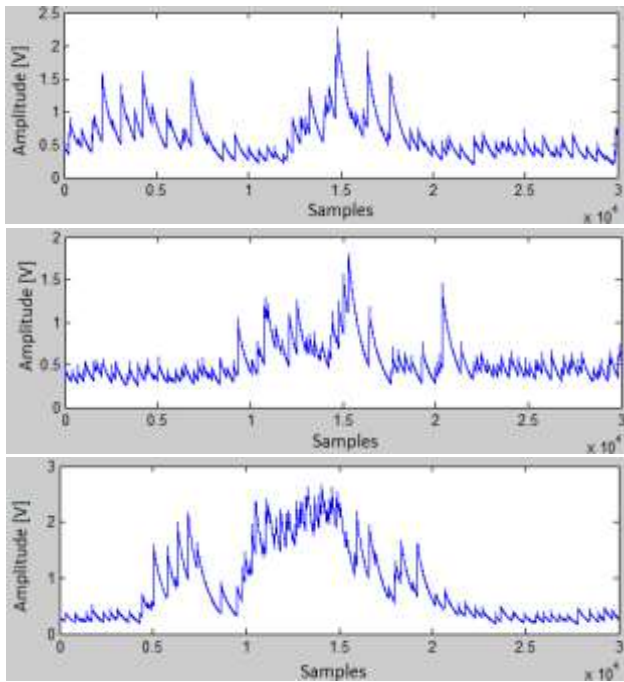

Fig. 20. Records of the top 5 thigh muscles.

The signals analysis was done in the time domain, by determining the maximum and minimum amplitude of the EMG signal emitted by every muscle. This analysis was performed in the envelope detector stage, because such amplitude variation occurs only between positive values because prior to this stage the signal is rectified.

Table 1 shows the average of the five records at different muscles.

Table 1. Signal amplitudes of the main muscles.

Muscle	Maximum amplitude	Minimum amplitude
M. Rectus Femoris	2.70886	0.17302
M. Vastus Lateralis	1.89388	0.1398
M. Vastus Medialis	2.10438	0.17864
M. Femoral biceps	2.23778	0.26496
M. Semitendinosus	2.73898	0.17300

Muscles that have higher variation (see Fig. 21) in amplitude are the rectus femoris and semitendinosus.

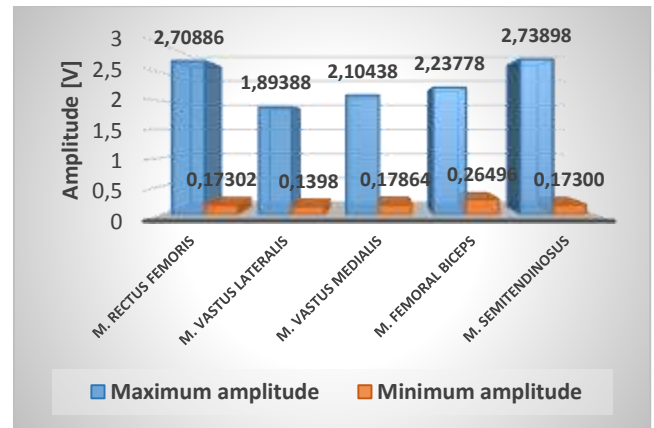

Fig. 20. Records of the top 5 thigh muscles.

However, to control the amplitude variation of the output signal of the card in the normal march cycle, through a muscle, it must be developed prior training process. Therefore the workout would take longer and would be more difficult to realize with the semitendinosus muscle, because the physiological muscular control is not the same as in the case of the rectus femoris. Therefore, the rectus femoris can have voluntary muscle contractions with greater control.

#### IV. CONCLUSIONS

- The analysis of the signals of the muscle groups quadriceps and hamstrings were performed using techniques in the time domain, by determining the maximum and minimum amplitude of the recorded signals of different muscles in a voluntary muscle contraction during normal march cycle.
- The electrodes used were to Ag / AgCl of the DORMO mark, these electrodes are commonly used for electrocardiography in pediatric patients, and by having good biomedical characteristics are compatible and meet the requirements for use in electromyography.
- The cost of the card design of EMG signals developed in this project is significantly reduced, about 72% less compared to the cost of the Muscle Sensor v3 card, available in stores nationwide electronic.
- Electronic components used to build the different circuits of the card, are easily accessible in major electronic stores nationwide.
- In the implementing of the conditioning stages it was necessary designing an integrator circuit at the output of instrumentation amplifier to decrease offset voltage and prevent the device from entering saturation..
- Tests with the card of conditioning developed at work allowed identify the main muscles that influence the movements of flexion and extension of the knee in the normal march cycle, are the rectus femoris and

semitendinosus with maximum amplitudes of 2.7 [V] using a total gain of 27,280.

- The location and the proper orientation of the electrodes determine the amplitude and signal quality, also permitting that the common mode signal may be rejected efficiently by the instrumentation amplifier.

## V. RECOMMENDATIONS

- Experiment with the location of the reference electrode to determine the optimal separation from the electrodes of the differential signal, in the case of people with transfemorals amputations.
- The values of the electronic components should be as close as possible to those resulting from the calculations, especially the components that make up the high pass filters, low pass and notch, since these circuits are most sensitive to the component tolerances and this depend precision the filtering of signal..
- The cable length of the electrodes should be as short as possible, since the interferences in myoelectric signal that transmit the cables to the card, increases the greater the length of the cable.
- In the location of electrodes in the muscles of interest to acquire the myoelectric signal, the skin should be shaved and cleaned with alcohol to reduce fat and skin impedance, this also helps in good adhesion of the electrode avoiding the presence of air between skin and the electrode.
- Do not use excessive profits on the instrumentation amplifier, since excessive of gain generate noise in the signal, affecting the characteristics of the EMG signal and also cause the saturation of the instrumentation amplifier.
- The recording of myoelectric signals should be conducted in an environment free from interference and devices connected to the AC power, as this would distort the acquired signals due to ambient noise.
- The connector cables of the electrodes connected to the input of the card must be the same type, because the use of other types of connectors may damage the device.
- In the manipulation of ferric perchloride acid, take every precaution and necessary safety standards, using: latex gloves, goggles and protective airway, since the risks of direct contact with skin, eyes or ingestion are harmful to health.
- Perform the circuit implementation with Surface Mount Technology (SMT) to optimize the size and quality of the device.

- To improve the conditioning of the myoelectric signals and get better quality signals, one could design a digital filtering with higher order filters to those used in this study.

## VI. ACKNOWLEDGEMENTS

The author is grateful for the help and support provided by PhD. David Ojeda investigator of Project Prometheus, SENESCYT, Ecuador. The Ing. Gabriela Verdezoto, guardian of this work, thanks to the contribution of their knowledge was possible successfully conclude the investigation and also to thank the administrative part of the Mechatronics Research Group at the Universidad Técnica del Norte by making development possible of the same.

## VII. BIBLIOGRAPHIC REFERENCES

- [1] Chan, M. & Zoellick R. B. (2011). World report on disability, WHO. Retrieved December 10, 2014, from: [http://www.who.int/disabilities/world\\_report/2011/en/](http://www.who.int/disabilities/world_report/2011/en/)
- [2] MSP, H. G. (2014). Taller de Órtesis y Prótesis. Loja. Retrieved December 12, 2014, from: [https://www.compraspublicas.gob.ec/ProcesoContratacion/compras/PC/bajarArchivo.cpe?Archivo=32Im4JIZt9JQX21LrlvqO4HyDRtH81mQaneFVVgc\\_hg](https://www.compraspublicas.gob.ec/ProcesoContratacion/compras/PC/bajarArchivo.cpe?Archivo=32Im4JIZt9JQX21LrlvqO4HyDRtH81mQaneFVVgc_hg),
- [3] Webster, J. G. (2006a). Encyclopedia of Medical Devices and Instrumentation (Vol. 3). New Jersey: John Wiley & Sons, Inc.
- [4] De Luca, C. J. (2002). Surface Electromyography: Detection and Recording. Delsys Inc.
- [5] Criswell, E. (2011). Cram's introduction to surface electromyography (Second ed.). United States: Jones & Bartlett Publishers, LLC.
- [6] Enderle, J. D., & Bronzino, J. D. (2012). Introduction to biomedical engineering (Third ed.). United States: Elsevier Inc.
- [7] SENIAM. (2015). Surface Electromyography for the Non-Invasive Assessment of Muscles. Retrieved January 06, 2015, from: <http://www.seniam.org/>
- [8] Basmajian, J. V., & De Luca, C. J. (1985). Muscles Alive (Fifth ed.). Baltimore: Williams and Wilkins.
- [9] Analog Devices, AD620 (1999). Datasheet AD620 Retrieved March 12, 2015, from: [http://www.datasheetcatalog.com/datasheets\\_pdf/A/D/6/2/AD620AN.shtml](http://www.datasheetcatalog.com/datasheets_pdf/A/D/6/2/AD620AN.shtml)
- [10] Sedra, A. S., & Smith, K. C. (2002). Circuitos microelectrónicos (Cuarta ed.). México: Oxford University Press.



## VIII. BIOGRAPHY OF THE AUTHOR

### Franklin Santiago Cadena Meneses



Born in the city of El Angel - Espejo Canton - Province of Carchi Ecuador, on March 25, 1992. Their secondary studies were conducted at the Instituto Tecnológico 17 de Julio, specializing in automotive mechanic, where he earned the medal for being the best student of the institution. He participated in the National Interuniversity Competition LOGO! - SIEMENS. He was a speaker at the International Congress APCASE 2015 by the IEEE in Quito with the journal article "Acquisition and Conditioning of electromyographic Signals for Prosthetics Legs". Currently he is a graduate of the Universidad Técnica del Norte – Ibarra in the Mechatronics Engineering in 2015. Areas of interest: Biomechatronics, mechatronics.