

A-A (1 : 10)

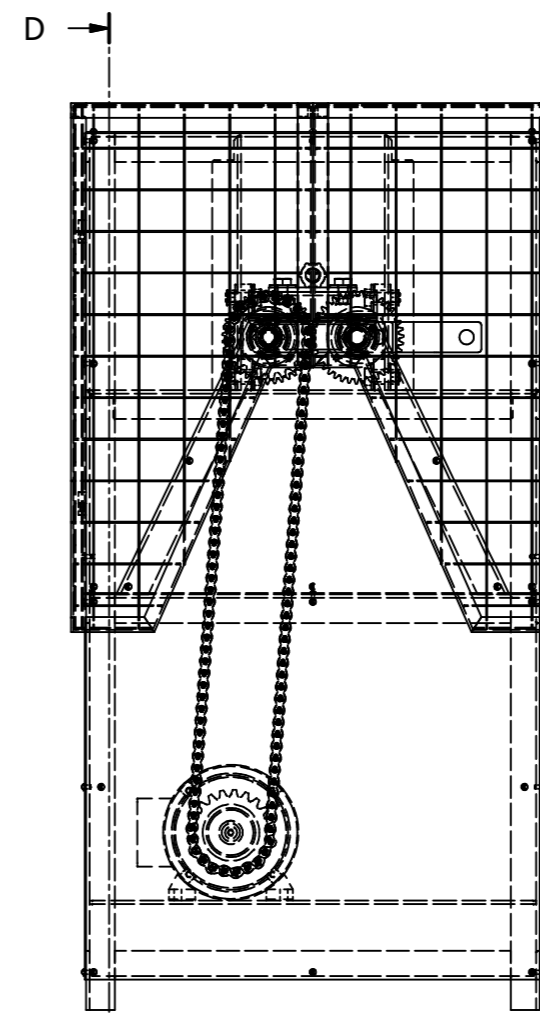

D-D (1 : 10)

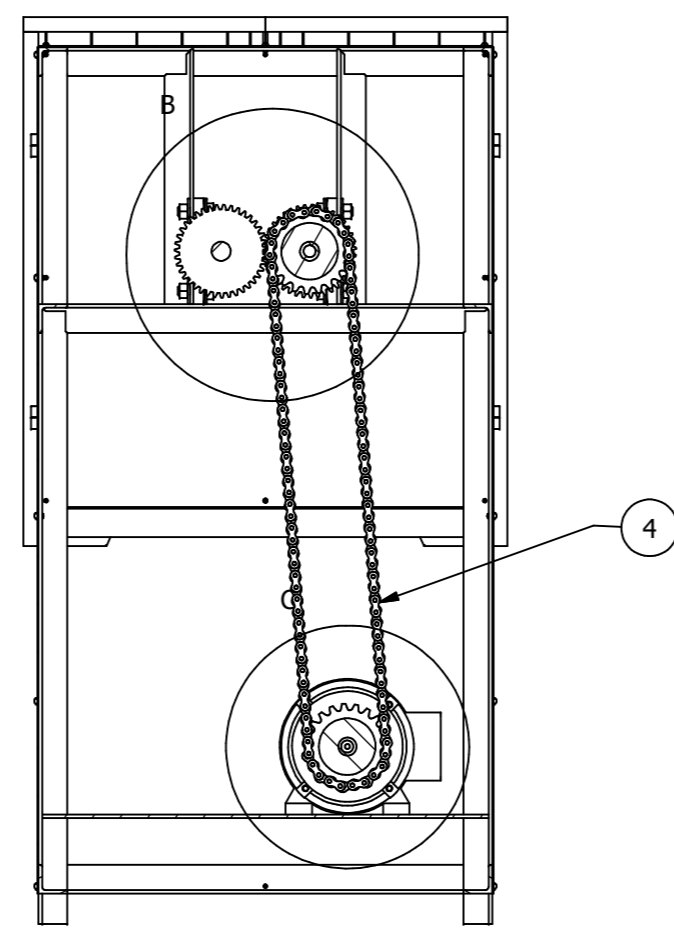
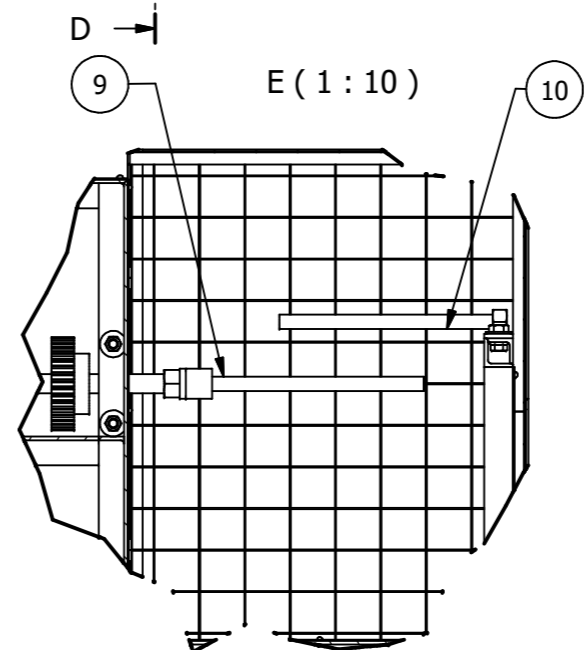
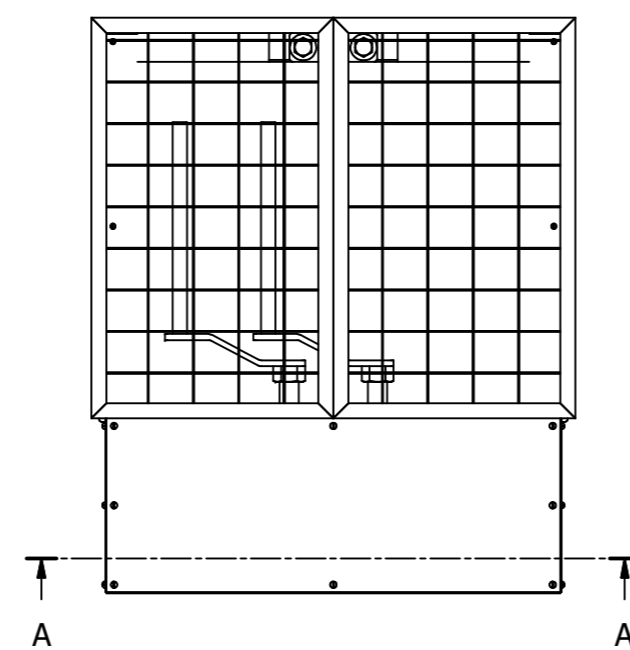
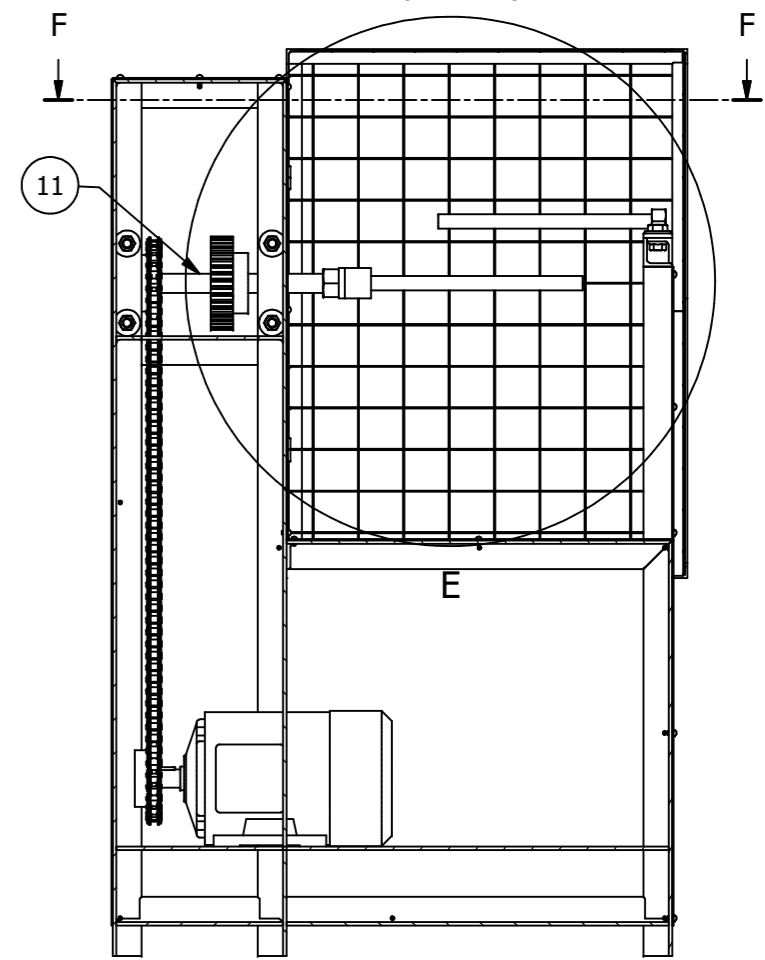

E (1 : 10)

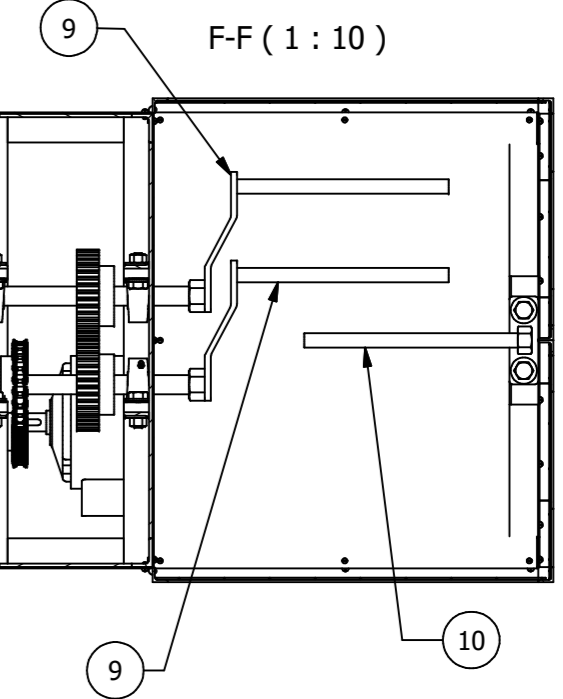

F-F (1 : 10)

C (1 : 4)

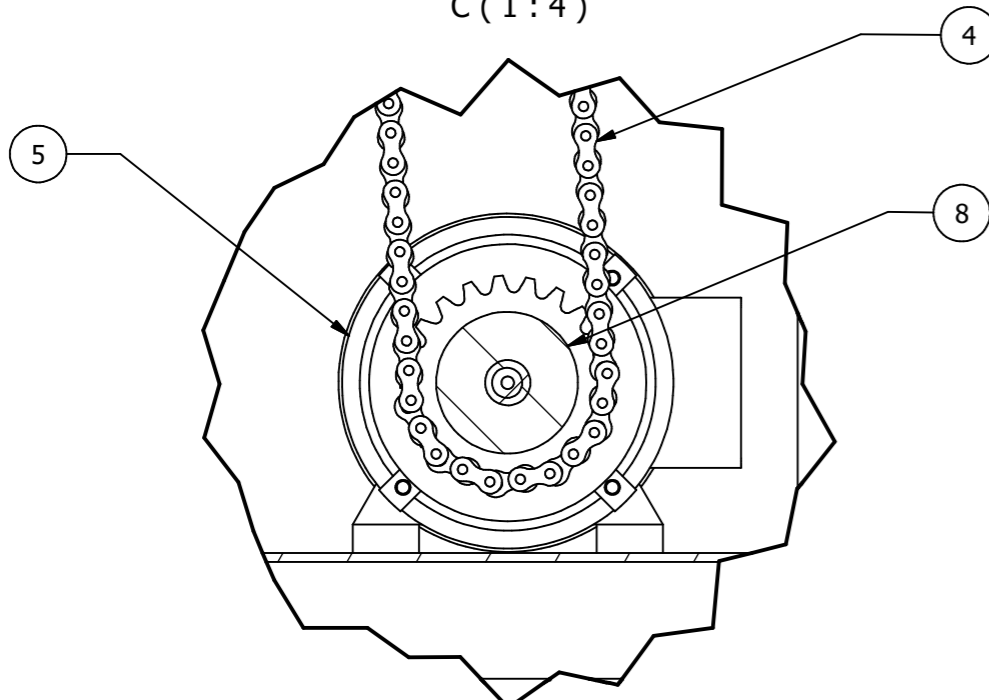

B (1 : 5)

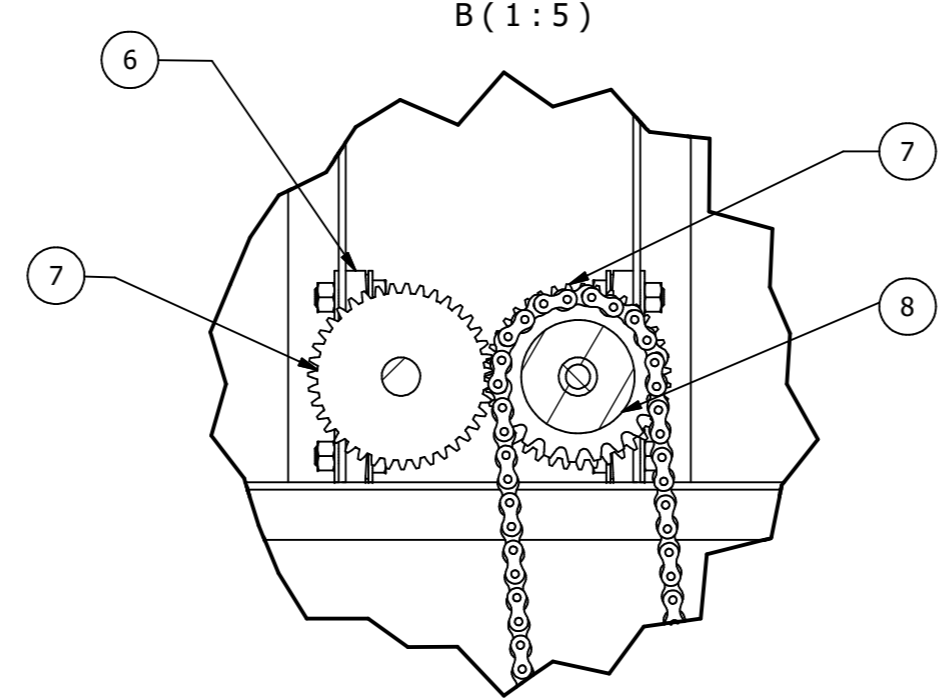

Nº	DENOMINACIÓN	MATERIAL	ZONA	CANTIDAD	CODIGO	OBSERVACION
1	MALLA	ACERO AL CARBONO	A1	1	ASTM A-500	
2	REJILLA DE PROTECCIÓN	ACERO AL CARBONO	A2	1	ASTM A-500	
3	ESTRUCTURA	ACERO AL CARBONO	A3	1	ASTM A-500	
4	CADENA ANSI 50	ACERO AL CARBONO	D2	1	ASTM A-500	
5	MOTOR 2HP		E2	1		
6	CHUMACERA P206	ACERO AL CARBONO	D2	2	ASTM A-500	
7	ENGRANE DE ACERO 33 DIENTES - 20°	ACERO AL CARBONO	E2	2	ASTM A-500	
8	PIÑÓN CADENA SIMPLE PASO 15 MM	ACERO AL CARBONO	F4	2	ASTM A-500	
9	BRAZO AMASADOR	ACERO INOXIDABLE	A7	2	AISI 304	
10	EJE FIJO	ACERO INOXIDABLE	A8	1	AISI 304	
11	EJE DE TRANSMISIÓN	ACERO AL CARBONO	A5	2	ASTM A-500	

Tolerancia: 0.01		Masa: 108,139 kg		Materiales: CONJUNTO TOTAL	
Fecha: 07/07/2017		Nombre: LÓPEZ B.		Denominación: MÁQUINA ESTIRADORA DE MELCOCHAS CON CAPACIDAD PARA 25 LIBRAS DE MASA	
Rev.: 10/07/2017		VALENCIA F.		Escala: 1 : 8	
Apro.: 10/07/2017		VALENCIA F.		Registro:	
Firma:		Número del dibujo: CIME-LB-0001		Sustitución:	
Edición	Modificación	Fecha	Nombre		