

UNIVERSIDAD TÉCNICA DEL NORTE

FACULTAD DE INGENIERÍA EN CIENCIAS APLICADAS

CARRERA DE INGENIERÍA EN ELECTRÓNICA Y REDES DE
COMUNICACIÓN



INFORME CIENTÍFICO EN INGLES

TEMA:

“SISTEMA DE MONITOREO DEL NIVEL DE AGUA DE UNA
LOCOMOTORA A VAPOR MEDIANTE TECNOLOGÍA GPRS EN EL
RECORRIDO IBARRA – OTAVALO PARA LA ESTACIÓN DE
FERROCARRILES DE LA CIUDAD DE IBARRA”

AUTOR: EDISON SANTIAGO LUCERO LUCERO

DIRECTOR: ING. DANIEL JARAMILLO

IBARRA - ECUADOR

ABRIL 2016

MONITORING SYSTEM WATER LEVEL OF A STEAM LOCOMOTIVE GPRS TECHNOLOGY BY TRAVEL IBARRA - OTAVALO FOR RAILWAY STATION CITY IBARRA

Edison S. Lucero L.

lcrstag@gmail.com

Ingeniería en Electrónica y redes de Comunicación, Universidad Técnica del Norte, Ibarra - Ecuador

Abstract- This project is based on the design and implementation of a system to monitor the water level in the TENDER or tank of a steam locomotive, this stems in learning the basics of monitoring systems, electronics and communications in addition to the wireless inquiry bibliographic resources to deepen the knowledge with which an interface is generated to extract and visualize data water level in a web application using a internet hosting storage.

Index Terms-Monitoring, GPRS, Database, Hosting.

I. INTRODUCTION

Since its inception steam locomotives come with the desire to communicate cities with transportation of both people and heavy cargo and over time these have become almost obsolete. In recent years and with the help of the National Government of Ecuador these machines have undergone rehabilitation to circulate can return to but this time for tourism.

These locomotives operate based water vapour, the water is stored in tanks which through pipes are heated to produce said steam causes the locomotive, a fault in this element does not move the locomotive stops operating causing accidents the road or simply the cessation of travel. To prevent inconvenience a technological solution that meets this need is required.

II. THEORETICAL FUNDAMENT

A. MONITORING SYSTEM

A monitoring system is based on a process of collecting information from one or more sources are these temperature, humidity, water level, etc., at certain intervals of time, which results are obtained for evaluation and achieve planning using the data obtained.

B. OPERATION OF STEAM LOCOMOTIVE

Basically the main component of a steam locomotive is water, this must enter a boiler through ducts or pipes from the TENDER or storage tank.

When the water reaches the boiler is heated reaching its boiling point based on the combustion generated by some materials such as wood or coal, and steam is generated.

Now, the steam generated is directed towards the cylinders of the engine, unable to free itself generate a strong pressure makes it possible to move the locomotive.

Water levels that have the locomotive TENDER ranging from 1 to 40.9 inches or its equivalent in gallons of 66.08 to 2705.64 gallons.

It performs measurements for a table in which values converted to gallons inches as shown in Figure 1 is was reflected.



Fig. 1: Measure plates Water and Fuel

C. WIRELESS COMMUNICATION SYSTEMS

Wireless communication systems work through waves traveling through space, wireless technology uses radio frequency wave's low power and a specific band, these bands can be private or public.

1) *No Licensed Wireless Systems*

Systems operating in licensed bands are not an option for the use of a low-cost wireless communication. Unfortunately as it mentioned limiting the scope.

2) *Satellite System*

Satellite systems are a great choice in the field of wireless communications, its biggest advantage is the scope and covering all the earth. But the downside is the cost for dedicated links.

D. WIRELESS TECHNOLOGIES

Broadcasting: A more restricted than that of radio, wireless radio frequency waves or concept as it Relates Solely Intended to transmissions to be received by a group of listeners.

1) *WI-FI*

It is a mechanism for connecting electronic devices wirelessly, such devices can connect to the Internet through an access point wireless network.

2) *EDGE (ENHANCED DATA RATES FOR GSM OF EVOLUTION)*

EDGE is considered an evolution of GPRS (General Packet Radio Service). This technology works with GSM networks. Although EDGE works with any GSM GPRS have implemented, the operator must implement the necessary updates, plus not all mobile phones support this technology.

3) *UMTS (UNIVERSAL MOBILE TELECOMMUNICATIONS SYSTEM) o 3G*

The third generation mobile systems (3G). It allows connection speeds of up to 2 Mbps, but in good condition. The speed varies depending on the coverage and speed that allows you phone provider.

4) *HSDPA - HIGH SPEED DOWNLINK PACKET ACCESS*

It is a technology based on 3G network that can support speeds up to 7.2 Mbps. It has a top speed of about 3 Mbps, but this is useful for mobile TV streaming and other data transmissions high end.

5) *4G NETWORKS*

4G networks refers to the fourth generation mobile phone technologies. Is the successor of 2G and 3G technologies, and has maximum data transmission speed of 100 Mbit / s for high mobility and 1 Gbit / s for low mobility; like other technologies, how much better the coverage and proximity of the antenna that gives service, the better the rate.

6) *GPS SYSTEMS*

The (General Packet Radio Service) GPRS systems are a good way to meet the needs of data transmission using the cellular network, these systems are based on (GLOBAL MOBILE COMMUNICATION SYSTEM FOR) GSM systems. In addition these systems unify the cellular network with the Internet which has the ability to transmit data packets from one end to another.

E. COMPARISON OF TECHNOLOGIES

The following table wireless technologies with their respective average speed is shown, but each of these responds to applications that are used, it must be remembered how many resources are to be used to access any of these technologies.

Table 1

Comparing technologies in terms of transmission speed.

Tecnología	Velocidad promedio de bajada	Velocidad promedio de subida
WIFI	100 y 600 Mbit/s	
GSM (2G)	1.8 kB/s	1.8 kB/s
GPRS (2.5G)	7.2 kB/s	3.6 kB/s
EDGE (2.75G)	29.6 kB/s	29.6 kB/s
UMTS 3G	48 kB/s	48 kB/s
HSDPA (3.5G)	3,6 MB/s	384 kB/s
LTE	40.750 MB/s	10.750 MB/s

Note: Table speed of each technology.

In addition to Table 1 is the comparison in terms of coverage and / or scope.

Table 2.

Comparing technologies in scope and frequency of operation

Tecnología	Alcance	Frecuencia de Operación
WIFI	0,01 – 0,1 Km	2,4 GHz y 5 GHz
GSM (2G)	30 Km	380, 410, 850, 900, 1800, 1900 MHz
GPRS (2.5G)	35 Km	850, 900, 1800, 1900 MHz
EDGE (2.75G)	30 Km	850, 1900 MHz
UMTS 3G	Mayor a 35 Km	1900, 2000, 2100 y 2200 MHz
HSDPA (3.5G)	Mayor a 35 Km	850, 1900 MHz
LTE	Mayor a 35 Km	1700, 2100, 2600 MHz

Note: The comparison table is having in scope

F. CHOICE OF TECHNOLOGIES AND ATTENDANT

Regarding distance, based on the table above technologies theoretically surpass the second generation have a sufficient range (about 30 km) to maintain a connection with the cellular network. Thus, most from 2G technologies can be applied to the project.

As for coverage, under ideal conditions, all technologies have their geographic area covered by a base station. But in practice, in some sectors of the geography of Ecuador there are low levels of signal strength.

As for the application, most technologies have tried to meet the demand for transmission rate for applications on mobile devices, taking into account this background the monitoring system does not need a high transmission rate, rather a media access or regulate internet.

Regarding costs involving the project, GPRS systems technology development that are cheaper on the market, compared with technologies which have high transmission speeds.

G. SOFTWARE AND HARDWARE ELEMENTS

The hardware and software are useful tools in combination can generate large projects and solve many problems in everyday life. Some components are defined below in order to assess their advantages and disadvantages for use in the monitoring system.

1) PIC microcontrollers

The PIC is a family of RISC microcontrollers made by Microchip Technology and derivatives PIC1650, originally developed by the microelectronics division of General Instrument.

The current name is not an acronym. In fact, the full name is PICmicro, although generally used as Peripheral Interface Controller (Peripheral Interface Controller).

- SOFTWARE PIC

One software that is easy to use and high level is called PIC C COMPILER and its characteristics according to the official website of CCS COMPILER:

- When compiling generates very compact and efficient machine code.
- It Integrates perfectly with MPLAB and other simulators / emulators like PROTEUS for the debugging process.

2) AVR Microcontrollers

The AVR is a family of RISC microcontrollers ATMEL US manufacturer. It has enough fans because of its simple design and ease of programming.

The following types exist:

- ATxmega
- ATmega
- ATtiny
- AT90USB
- AT90CAN

- PROGRAMMING SOFTWARE

One of the programs for AVR compiler called AVR codevision and is a program that has gained popularity among various circles of development with ATMEL microcontrollers.

3) DEFINITION OF ARDUINO

ARDUINO a hardware platform is open source, based on a simple plate with inputs and outputs, analog and digital, in a development environment that is based on the Processing programming language. It is a device that connects the physical world with the virtual world, or the analog and digital worlds.

a. ARDUINO HARDWARE

The use of pins on ARDUINO is very simple because it has a distribution useful enough according to the utility to be given for any application required.

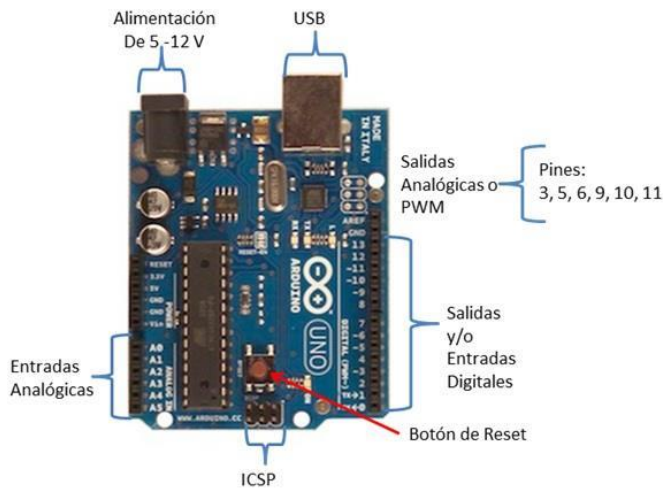

Fig. 2. ARDUINO peripherals

b. SOFTWARE ARDUINO

To write a program on an Arduino board must be installed in a computer programming environment that contains an editor, a compiler for translating the program interpretable language microcontroller and communication software for loading the program into memory through a USB port.

- Parts of a program made in ARDUINO
 - a. Block to declare variables and libraries
 - b. VOID block configuration SETUP ()
 - The operation mode is described PINs
 - Serial communication, etc.
 - c. VOID execution block LOOP ()
 - i. It is described as infinite loop execution

c. MODULE GSM / GPRS SIM900 SHIELD

Electronic systems have mostly evolved to try to have many more tools to use in their embedded systems, which is a great advantage, since it is not necessary to use various materials but acquire a system that meets our needs and dock another to multitask.

This module works based on a chip from an operator of cellular network operators with which the module works listed below.

- CONECEL S.A., CLARO
- OTECEL S.A., TELEFÓNICA
- CORPORACIÓN NACIONAL DE TELECOMUNICACIONES, CNT.



Fig. 3. SHIELD GSM/GPRS SIM900

d. APPLICATIONS

- Applications M2M (Machine 2 Machine) - To transfer control data via SMS or GPRS between two remote machines.
- Remote control devices - Send SMS while in your office to turn on or off equipment at home.
- Remote Weather Station or Wireless Sensor Network - create a sensor node capable of transferring data from sensors (such as a weather station - temperature, humidity etc.) to a web server.

e. SIM900 AT COMMANDS

To use AT commands in this module should incorporate the SHIELD GSM / GPRS module to the Arduino board as shown in the following figure and add an algorithm to use.



Fig. 4. ARDUINO MODULE connection with GSM / GPRS SIM900 - UART

The code then performs communication between GSM / GPRS and ARDUINO module via serial interface.

```

Sin título: Bloc de notas
Archivo Edición Formato Ver Ayuda
Se añaden las librerías necesarias para que exista la comunicación entre Modulo y placa ARDUINO
#include <SoftwareSerial.h>
Se procede a escoger los pines que servirán de vía para la comunicación serial
SoftwareSerial GPRS(7, 8);
Se declara un vector para recibir los datos sobre el puerto serial
unsigned char buffer[64];

Se declara un contador para el llenado del vector
int count=0;
Esta es la función que se encargará de la configuración de BAUD RATE para que exista la comunicaci
void setup() {
  GPRS.begin(9600);
  Serial.begin(9600); }
Esta función realiza una lectura de los comandos que se ingresan por comunicación serial
void loop() {
  if (GPRS.available()) {
    while(GPRS.available()) {
      buffer[count++]=GPRS.read();
      if(count == 64)break; }
    Serial.write(buffer,count);
    clearBufferArray();
    count = 0; }
  if (Serial.available())
    GPRS.write(Serial.read()); }
void clearBufferArray() {
  for (int i=0; i<count;i++) {
    buffer[i]=NULL; } }

```

Fig. 5. Serial Communication Configuration ARDUINO

The basic commands between the Arduino board and GSM / GPRS module are:

Table 3.
Basic AT commands SIM900

Comandos	Respuesta	Descripción
AT	OK	Respuesta Confirmación SIM900
ATD	OK	Realizar Llamada
ATH	OK	Colgar Llamada
ATA	OK	Responder Llamada
AT+CMGR	OK	Envía Mensaje de Texto
AT+CMGL	OK	Lista Mensajes de Texto

Note: the basic commands used in serial communication are presented.

4) CHOICE OF HARDWARE AND SOFTWARE

For the choice of hardware and software based take into account the flexibility, cost and usage characteristics.

Table 4.
Comparison Hardware and Software

hardware	PIC	AVR	ARDUINO
Tipo Micro	Microchip	ATmega	ATmega
Modelos	PIC16, PIC18, PIC12	ATmega8, ATmega16	ATmega328, ATmega168
Oscilador	Interno y Externo	Interno y Externo	Externo
Lenguaje	Básico C, ensamblador	C	C
Licencia Software	Pago	Pago	Libre

Note: Analysis for comparing the software and hardware components for the project.

a. Software licenses

As shown in the above table, the issue is a limiting license in compilers both PIC and ATMEL, such compilers need a license fee to use all the features of the program.

b. Flexibility

Another limitation is that it could not be scalable to add other tasks to the same system, ie if an electronic board in which only serial communication and a pair of pin input / output intervene, the plate itself is designed could not It is adapted to perform other tasks.

Po its characteristics was chosen ARDUINO as a tool to use the project as it is not limited to use license, in addition to being a type trainer plate is a scalable tool, ie, if needed add other features to the system, simply designate more jobs input / output for different uses.

5) CHOICE OF HARDWARE AND SOFTWARE

Sensors are devices that can translate the physical variables such as temperature, humidity, water level, etc., to values that can be understood by people.

a. TYPES OF WATER LEVEL SENSORS

There are a number of sensors to measure level in the market, but each of these has certain characteristics depending on their application and use. Sensor types that exist below.

- *Capacitive Level Sensors Type*

This type of sensor is useful in most solid and liquid, and its operation is based on a capacitance electrode to be introduced into the tank. If you change the capacitance changes the water level.



Fig. 6. Capacitive level sensor

- *Conductive Level Sensors Type*

This type of sensor electrodes installed in a water tank are based for measurement of level, its limitation is that it can only warn against high or low water levels as the electrodes used.



Fig. 7. Conductive Level Sensor

- Photoelectric sensors Level Type

This sensor is based on the change of refraction of a quartz light conductor when immersed in water. Its operation is based on the reception of light or dispersion thereof by the photoreceptor.



Fig. 8. Photoelectric sensor

- Hc-SR04 Ultrasonic Sensor

The HC-SR04 ultrasonic sensor measures distances and has the ability to detect objects and estimate the distance that is in a range of 2 cm to 4 meters.

The operation is not affected by sunlight or black material such as optical rangefinders (although acoustically soft materials such as fabrics can be difficult to detect)



Fig. 9. HC – SR04 Sensor

6) CHOICE OF SENSOR

For the choice of sensor is used to the characteristics of each of these, the scope, power consumption and also keep in mind that the structure of TENDER or tank locomotive from damage.

Table 5

Compare Sensors

Sensores	Energía	Alcance	Daño Estructura
Tipo Capacitivo	200 mA	5 cm - 25 cm	Si
Tipo Conductivo	20 mA	10 cm - 8 m	Si
Fotoeléctrico	35 mA	5 cm – 15 m	Si
Ultrasónico	15 mA	2 cm – 4 m	No

Note: The comparison of these sensors through the energy they consume, its scope and structural design is performed.

As shown in the above table, the power consumption is proportional to the scope, ie more far-reaching is the energy required in addition to the installation of each of these sensors (except the ultrasonic sensor) is necessary to make changes structure which was not allowed by the company.

7) BATTERY

A key part in electronics is the use of batteries for systems to have utility without dependence always be connected to an electrical outlet, based on this principle the need for a battery to remain in operation for at least a whole day of work are batteries LI-PO.

a. LIPO BATTERY

These batteries are a differentiation of lithium ion batteries (Li-ion). These allow greater energy density and a higher rate of discharge.

- Capacity (mAh)

It is the time amperage supplied to a load. In theory it says that a 1300 mAh battery will last for one hour if it works nonstop.

- Charge (C)

The amount of energy that the battery can generate is called Download followed by a C, measure the maximum discharge current for a period of time the battery can receive.

Assuming that the project would result consumes 1A (1 / 1.6 = 0.625), rounded, 1C, as the battery supports 20 - 30C no problems.

- Source (S)

Some of LIPO batteries have a nominal voltage of 3.7 V per cell, giving 4.2V when fully charged and there must never lose 3V when discharged.

Now, two-cell batteries have a voltage of 7.4V which is more than enough to feed a circuit like Arduino and its components.

8) WEB TOOLS

Use tools in the cloud they have made anyone connected to the Internet has access to all resources of the same. At the same time each administrator is able to access each utility in the same cloud.

There are several examples of applications such as:

- WEBMAILS

It is a way to access email through a browser, without installing or configuring any software on the computer from which you access the mail. (Child, 2010)

Mail applications are varied but they have something in common because they use servers which provide these services to users simply access them.

- WIKIS

These applications are pages in which a user is able to access and edit information through web browsers.

- WEBLOGS

They are websites created by a person, they are very diverse and often modifies also is easily accessible through a web browser.

- Online stores, etc.

Online stores are one of the most useful ways to buy things over the Internet. Its use is based on web applications or web pages which interact with providing services and other users.

- *HOSTING*

A "Hosting" is practically a PC in which all the information on a page, mail, databases, etc. is stored and has a connection to the Internet to download and display the information, this PC is called Server, as it provides an internal or external information, and a computer to access these services is called the client, receiving the information.

Types of Hosting

- Free
- Private or Payment

a. *Free hosting*

A free hosting is a server that stores information remotely, the user to access this service simply register your details on any of these hosting servers without any payment.

b. *Hosting Payment*

A paid hosting is a server that allows certain level of storage as the margin payment is given to the service that you have full control of the site.

- *LANGUAGE PHP and HTML*

The programming language is the form of interaction between an application and the ones and zeros that this represents. There are several programming languages used to develop web applications, among which are:

- PHP
- Java, with its technologies Java Servlets y JavaServer Pages (JSP)
- Javascript
- Perl
- Ruby
- Python
- C# y Visual Basic with its technologies ASP/ASP.NET

- *MYSQL*

It is a management system databases to relational databases. Whether MySQL is an application that allows the management of files called databases.

- *DATABASES*

A database is a set, collection or storage of data stored in a computer shortcut.

III. DESARROLLO DEL SOFTWARE Y HARDWARE

In the project a solution in terms of monitoring and data collection based on a web platform, for it is part of the dimensions of the steam locomotive to carry it arises, then proceed to an election system mails that can be adapted according to the needs, consequently will have a system design and final will proceed to build the web platform on which an interface intuitive enough will have and which monitoring is displayed on the course.

A) DIMENSIONS OF TENSION STEAM LOCOMOTIVE

The tender has a height of about 1 meter, this point was taken from the base to the ceiling where is the tank lid.

Tender width is about 2.6 meters and a length of 2.5 meters. Now, the measure or requirement is taken into account for the use of a sensor is height.

B) BLOCK DIAGRAM SYSTEM OPERATION

The block in which the locomotive is observed showing the place where the electronic system is 10 cm after water inlet gate and performs the task of sensing the water level in the same stands.

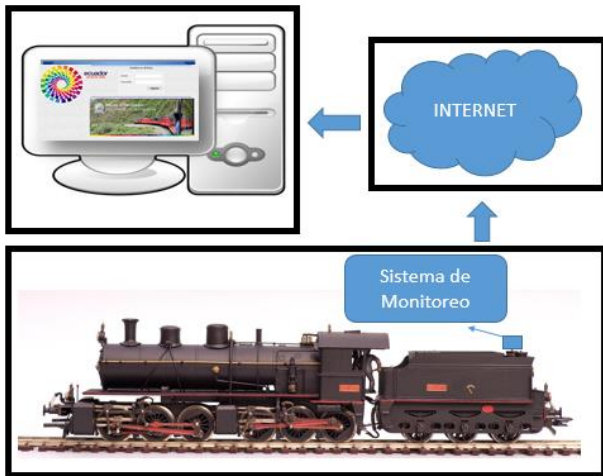

Fig. 10. Operating diagram of the entire system

The operation of the entire system is simple, the electronic system is responsible for measuring the water level in the tender of the steam locomotive, then this data is sent over the GPRS network to a server or hosting on the Internet.

Data sent through the GPRS network are stored on a server or hosting for later analysis. This data is displayed using a web application and can be accessed from any computer either at the central station or any device with internet access.

C) SYSTEM REQUIREMENTS

As the requirements shown in the above block diagram for the system to work are:

- 1) Company
 - Having a computer or mobile device with a web browser
 - Access to the Internet or data
- 2) Electronic System
 - GSM / GPRS system with data access or available balance

Internet access should not be a bandwidth as high as downloading information or data monitoring system is not very high.

D) ELECTRONIC SYSTEM DESIGN

The state of the arrows in the figure below shows how the communication is unidirectional, this is because the device will measure the water level simply transmits the data to the electronic block and electronic block sends this data via GPRS to a server or hosting on the Internet.

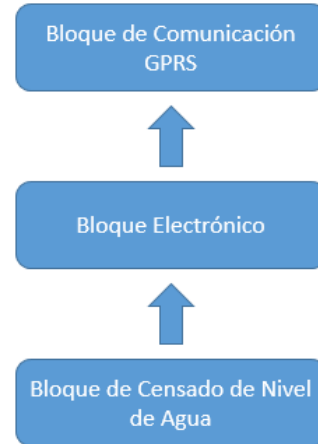

Fig. 11: Blocks Electronic System

E) ENERGY SYSTEM REQUIREMENTS

The system has a battery which is incorporated in the electronic system based on energy considerations for each device.

Table 6
Power system devices

Dispositivo	Corriente	Voltaje
ARDUINO	120 mA	7 a 12 V
MODULO GSM/GPRS	250 mA	3.2 a 4.8 V
Sensor Ultrasonico	15 mA	4.5 a 5.5 V
TOTAL	375 mA	

Note: For power consumption ARDUINO took into account the current flowing in each digital pin I / S (input / output) that is 40 mA, the two pins I / use S is considered 80mA also consumption pins ARDIUNO and communication between the module and IED warning GPRS approximately 120 mA is used and corresponds to a power consumption of 0.6 watts.

1) ELECTRICAL CIRCUIT DESIGN

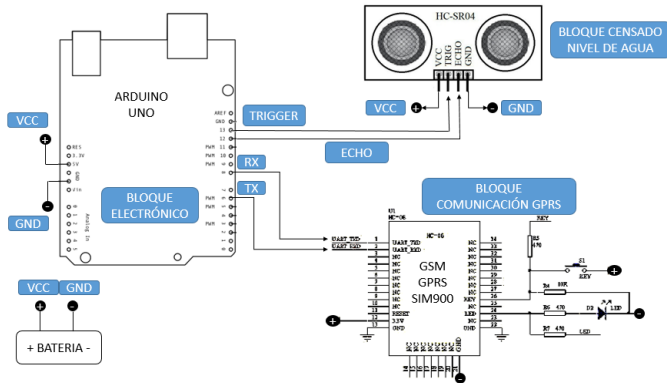

Fig. 12: Electrical circuit System

The electrical circuit which consists of the same above but now in the form of electrical diagrams, components also will show what the pins used in the project are presented.

As noted, Arduino pins Transmission and Reception for serial communication is used, in addition to the use of pins 12 and 13 ARDUINO for ultrasonic sensor.

F) ALGORITHM OF ELECTRONIC SYSTEM

The system should work as follows or based on the following sequence of instructions:

- The system Lights
- The sensor measures the water level in the tank periodically.
- The Arduino board performs the calculation time and distance based to water in the tank.
- Conversion of these values to inches and gallons.
- If the measure is below the level requested. an alert message is sent to the operator.
- If the measure is considered acceptable level sensing continues.
- After sensing the water level, the GPRS connection by the GSM / GPRS module starts.
- Sending is performed measuring the level of water through GPRS.
- The GPRS connection is closed.
- Cycle continuous level monitoring.

G) WEB SITE DEVELOPMENT DATA ACQUISITION

The language used for data acquisition is PHP and HTML, as previously mentioned when using pure programming language further development of the instructions in the hosting is achieved.

PHP orientation was to acquire data from the GPRS, and SQL queries using variables to store them in the database we need.

1) FLOWCHART OF THE WEB APPLICATION - HOME

The algorithm using the home page is very simple and is detailed in a few instructions described below.

- The home page of the web application opens.
- The parameters username and password are entered.
- If the user or password are correct and exist in the database into the system
- If the username and password are incorrect or does not exist in the database does not enter the system.



Fig. 13: Working diagram INDEX PHP File

Once the user accesses the system should display options such as:

- Current Monitoring
- Save Monitoring
- Searching for a Record
- Get out of the system

Every action is needed to access the database requires a connection to it.

- To monitor accessed data sent by GPRS that are stored in the database.
- To save the current monitoring an SQL query is performed to create a point at which the current data are stored by date.
- To search for a record, an SQL query is performed to search by date stored records.
- To exit the system simply the session that began in the LOGIN or access to the system is closed.

2) FLOW CHART OF WEB APPLICATION -Monitoring

Once access to the monitoring system was obtained, several buttons which have an independent action of each other will be presented. The process is simple, it is true that each button performs a single task but there is an order in the monitoring process and therefore there is also an order in the use of the monitoring system of the web application.

- Being in the monitoring window
- Monitoring button is pressed to start it if necessary.
- If I press the button a screen monitoring status monitoring and a chart showing the monitored data is displayed.
- After the save button is pressed to store the data
- In the store window to save a calendar by date is displayed.
- If you want to search the data you press search.
- If the Logout button is pressed you exit monitoring system.

For the diagram file MONITORING PHP a selection of options showing the window and each of these performs a process is performed.

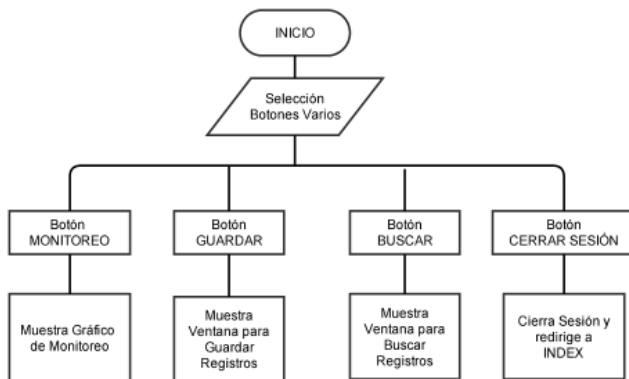

Fig. 14: Working diagram MONITORING PHP File

3) FLOWCHART OF WEB APPLICATION - SEARCH

To find a record need be pressed SEARCH button which displays a screen which allows you to search based on a record date.

The search process is as follows.

- While in the Search window
- The date on which it was stored is chosen
- If there is, records show
- If not, a link will be displayed to return and make a new search.

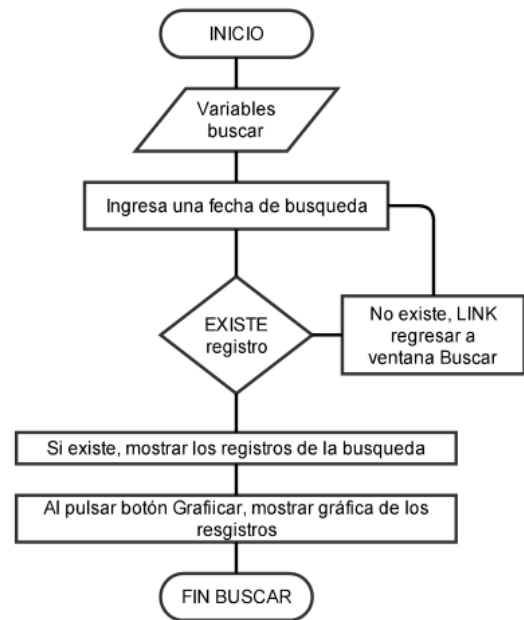

Fig. 15: Working Diagram Window SEARCH

4) FLOW CHART OF THE WEB APPLICATION - SAVE

In the GUARDAR As window simply the data is stored, whether just steps would be:

- While in the GUARDAR Window
- Choose date monitoring storage
- Press GUARDAR Log
- Wait for the window to close automatically.

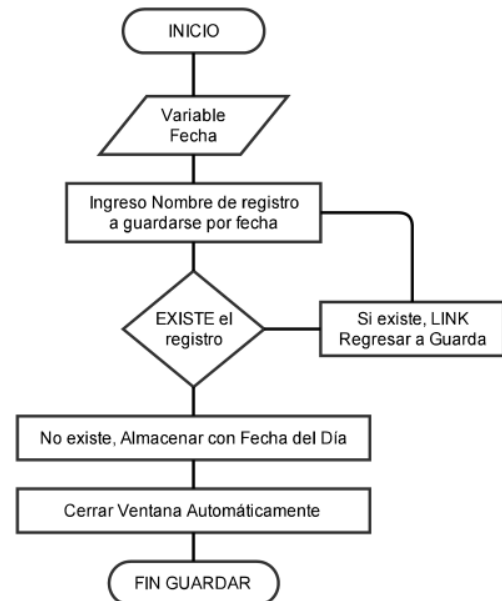

Fig. 16: Working Diagram Window GUARDAR

5) FLOW CHART OF THE WEB APPLICATION - LOGOUT

The process to follow to log is as follows:

- Located in the monitoring window
- The log and leaves the monitoring system button is pressed.
- The main window is presented.



Fig. 17: Working diagram Close Session

H) DISPLAYING THE WEB PAGE

The initial page or INDEX is "ferrocarriles.byethost4.com", so in the browser address <http://ferrocarriles.byethost4.com/> you type and displays the following start window.



Fig. 18: Monitoring system

The web application is divided into two parts, user part and the part managed.

User Part is where monitoring may be performed, store monitoring data and search such records



Fig. 19: Monitoring System for User

When registering as a user a window in which some buttons are observed, each with a consecutive function displays.



Fig. 20: Monitoring system for user

The steps for monitoring are detailed below for a better understanding of the practical system.

1. First, monitoring is initiated by pressing the button monitoring.



Fig. 21: Ongoing Monitoring

In this window you must select the monitoring mode, and will continue monitoring a past or current monitoring perform, it should be emphasized that this window is emerging and has a time of 15 seconds to close automatically.

- When choosing any option of monitoring the next window in which variables are monitoring the water level can be seen, the time and date that monitoring is performed is shown.



Fig. 22: Input Monitoring Interface

The fact of choosing the option "continue monitoring" makes the above monitored data are retained, and select the "new monitoring" the monitoring is deployed without any stored value, ie, monitoring starts from scratch.

Now, on the right side it is a link that says "Show", pressing on the link graphical monitoring interface opens, ie, in this place is observed graphically the values of the water level coming.



Fig. 23: GUI water level status

Having monitored can exit this window and continue with the procedure.

- In the main window is the Save button is pressed and stored choosing the date on which the monitoring was carried out.

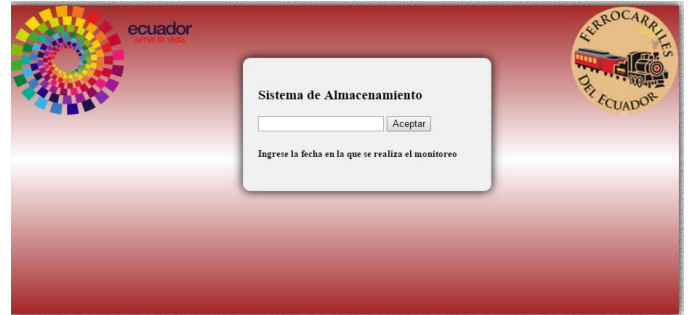

Fig. 24: Storing a monitoring conducted

- In the case of any registration require monitoring, press the button search and proceeds to retrieve a stored record or view previously writing the date was monitored.



Fig. 25: Log Search previous monitoring

- To exit the system, simply press the button and we log out of the system.



Fig. 26: Sign off

IV. IMPLEMENTATION AND VERIFICATION TESTS

In this chapter the implementation of the monitoring system described, the development of evidence thereof in order to have favorable results with the running system with the operating system, plus a description of the implementation and maintenance costs will be taken.

A) SYSTEM IMPLEMENTATION

The locomotive itself has a tank (TENDER) which provides both water and diesel for operation, as the dimensions of the TENDER (1 meter high, 2.6 meters wide and 2.5 meters long)

is known then the distance you have to measure the water level is based on height.

In the top two gates tender for filling water and diesel are present, has the greatest interest at this time is the gate at the back of the TENDER which is where water is supplied

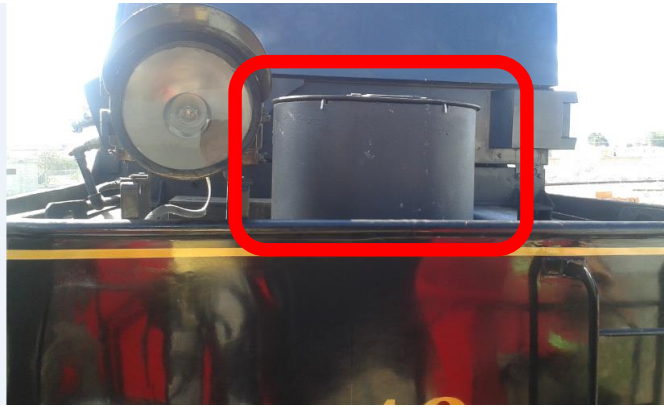

Fig. 27: Sluice Water Supply TENDER steam locomotive

The following figure shows where installation of water level probe located on the inside of the gate filled with water as the drilling system must be in contact with water by ultrasound was performed.



Fig. 28: Installation of water level survey

B) WEB MONITORING SYSTEM

For monitoring should have access to the Internet and the GSM / GPRS module sends the data to the internet, for which the web access system monitoring was performed.

For a better appreciation of the web monitoring system below a diagram which shows navigational access windows and some characteristics of each.

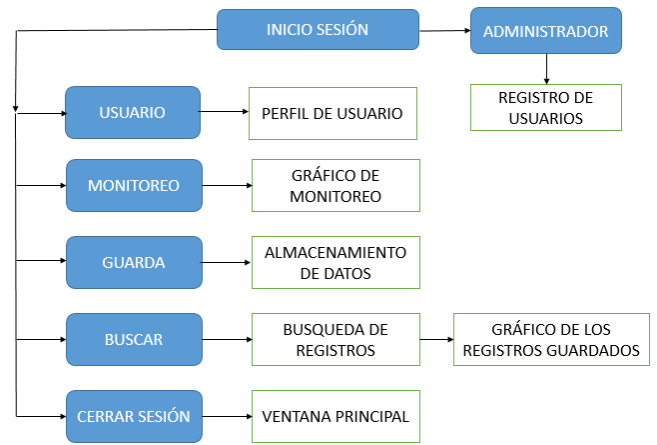

Fig. 29: WEB Navigation Diagram

In the diagram shown above can be seen that the first picture is the logon, this is first sense to choose between access modes are: user mode and administrator mode. In the first instance a person is responsible for access in administrator mode to create users who are authorized to perform monitoring.

C) TESTS AND RESULTS

To show tests the monitoring system was left installed on the locomotive and the usual procedure which was the annotation data of water levels in a data sheet was conducted. In the figure the departure of the steam engine in which the monitoring system is installed is shown. In the enclosed portion red it is where the system was installed.



Fig. 30: Exit locomotive monitoring system

Now, in the central railway station shown Ibarra engineering personnel responsible for monitoring the steam locomotive. Station personnel will be trained to use the system and monitoring tools (hardware) through user guides.



Fig. 31: Monitoring water levels in the steam locomotive.

In the figure above the water level monitored at that time, now these data do not exceed 1800 gallons of water according to the monitoring system installed is shown.

If these values are compared with the values recorded in the data sheet by taking manual values, the values are between 1750 and 1800 gallons. That is, the values obtained by the monitoring system at least gallons vary due to fluctuations of the locomotive in the path.

This is reflected in the data sheet shown in the following image, as shown in the part marked in red, two values are recorded water levels departure station and arrival to it.

Fig. 32: Registry values in data sheet Company

D) COST-BENEFIT ANALYSIS

To evaluate the usefulness of a project A cost-benefit analysis is used, it must take into account the social costs and benefits that the project has not only focus on the economic costs.

In addition the costs of maintenance and operation need the monitoring system was analyzed, this in order to ensure proper operation.

1) COSTS OF IMPLEMENTATION

Table 7

Cost Monitoring System		
Material	Cantidad	Costo
ARDUINO UNO kit	1	35 \$
MÓDULO GSM/GPRS	1	70 \$
SENSOR ULTRASONICO	1	10 \$
Batería de LIPO	1	25 \$
Cables, leds, baquelita, estructura, etc.	VARIOS	30 \$
TOTAL		170 \$

Note: Costs associated with the implementation of the monitoring system regarding electronic components are detailed in Table 7

These costs associated with data upload to hosting are reflected in the following table.

Table 8

Cost data transmitted for monitoring			
Datos	Unidad	C/U	TOTAL
Datos enviados	720	0,5 \$ x MB	0,50 \$
Mensajes alerta	2 por día	0,07 \$	0,14 \$
TOTAL			0,64 \$

Note: It takes into account an estimate of bytes transmitted in the worst case to make the aforementioned value.

Maintenance costs are reduced to circuit damage, operation, inspection and cleaning of the plates. Each of these costs is shown below.

For damage to the circuitry and operation, these damages are due to the misuse of electronic systems, also voltage fault for not providing enough power to the system. Considering that the Arduino and GSM / GPRS plates are created by microelectronics and complexly repairable it is advisable to always buy a new plate and when you check your fault and can continue no longer working.

Table 9

Estimated Annual Maintenance Hardware			
Mantenimiento	Componentes	C/U	TOTAL
Daño Hardware y Operatividad	ARDUINO	30 \$	30 \$
	PLACAS	5 \$	5 \$
	VARIAS		
	GSM/GPRS	70 \$	70 \$
TOTAL			105 \$

Note: This is an estimate of annual maintenance of the circuit.

For inspection and cleaning, this has more to do with the aspect of preventive maintenance in terms of cleaning dust and debris that may enter the system in the way.

Table 10

Estimate of Annual Maintenance Review			
Mantenimiento	Componentes	C/U	TOTAL
Revisión y Limpieza	ARDUINO	5 \$	5 \$
	PLACAS	5 \$	5 \$
	VARIAS		
	GSM/GPRS	5 \$	5 \$
TOTAL			15 \$

Note: Estimated maintenance as to annual review and cleaning system.

Software maintenance, this applies to possible future monitorios as other variables, that is, if scalability to add other variables such as temperature monitoring, accuracy, etc.

Table 10

Estimated Annual Software Maintenance			
Mantenimiento	Componentes	C/U	TOTAL
Mantenimiento Software	PROGRAMACIÓN	25 \$	25 \$
	ARDUINO		
	PROGRAMACIÓN	25 \$	25 \$
	WEB		
TOTAL			50 \$

Note: Annual maintenance based software in case of system errors or add code.

2) BENEFITS

As a public institution does not have economic benefits as the proceeds are for the state and to promote tourism but has social benefits which allow operators have increased productivity, since the implementation of the system has the following advantages.

- The water level data are displayed graphically without the need to resort to the old system of manual data collection.
- All data are accessible from any computer or device with internet access because they are stored in a database.
- At the end of each stroke of the locomotive you have to travel a statistical record by serving for both operators and for those responsible for the station and thus control the use of the vital liquid.
- One of the biggest benefits is avoid unnecessary spending of sheets of paper that operators used for each output of the locomotive, although registration is performed it every week but still a waste of this resource.

V. CONCLUSIONS

Wireless electronic systems currently provide great benefits in terms of mobility, but when added to these systems other tools, these electronic systems can play an endless task. For monitoring it is an example of the ways in which electronic and wireless systems exist to form new more complex systems capable of probing tasks and data transmission.

The monitoring system water level became a functional tool, easy to use thanks to electronic and easily accessible thanks to the Web and Internet tools. This trend of cloud storage makes data accessible from anywhere in the world to have an internet domain. In addition, these records are useful for Central Railway in Quito since they determine the outputs of trains in Ibarra and make available resources, in this case water and diesel in order to make way for the route Ibarra railway station.

The operators of the station will not have to be checking the water levels of the locomotive in motion manually along the way as this is a risk to their integrity, in addition, the system has helped operators can take their while in other equally important activities, this leads to improved productivity in the company.

The project is accomplished promote free software tools and hardware as an alternative for generating low cost projects and energy consumption also meet the expectations of the company.

Have reduced the estimated time of departure of the locomotive, ie, above, had to check water levels manually with a bar half inches, transforming a gallon and record sheets, these takes a couple of minutes . Now, this task is no longer necessary, simply turn on your computer and viewed from a computer with internet access and graphically these levels, and it takes several seconds whereupon the scheduled departure time from the station will be fulfilled without delay.

The monitoring system has proven to be functional, collect the data from time to time and send them to the Internet, besides being displayed by a web browser with Internet access. The most important thing is that these data are stored and will be accessible when required and that was one of the observations that this project was carried out.

REFERENCES

- [1] ACCUDICY. (31 de Marzo de 2015). http://www.accudiy.com/download/HCSR04_Manual.pdf. Obtenido de ELECTRONILAB: http://www.accudiy.com/download/HCSR04_Manual.pdf
- [2] Andersson, C. (s.f.). *GPRS y Aplicaciones Inalambricas 3G*. New York: Wiley Computer Publishing.
- [3] arduino.cc. (22 de Marzo de 2015). <http://www.arduino.cc/en/Main/arduinoBoardUno>. Obtenido de <http://www.arduino.cc/en/Main/arduinoBoardUno>: <http://www.arduino.cc/en/Main/arduinoBoardUno>
- [4] Atelin, P. (2006). *Redes Informáticas: Conceptos Fundamentales*. Barcelona: Recusros Informáticos.
- [5] Bolivar, U. S. (17 de Junio de 2015). *Redes de Computadoras II*. Obtenido de <http://ldc.usb.ve/~poc/RedesII/Grupos/G2/>
- [6] ByetHost. (30 de Abril de 2015). *Hosting*. Obtenido de <https://byethost.com/index.php/free-hosting>
- [7] Caivano, R. (2009). *Utilización de la WEB 2.0 para aplicaciones educativas*. EDUVIN.
- [8] Castañeda, Y. (8 de Julio de 2015). *SLIDESHARE - EL SONIDO*. Obtenido de <http://es.slideshare.net/profmat58/el-sonido-14>
- [9] Cobo, A., Gomez, P., & Perez, D. (2005). *PHP y MYSQL: Tecnologías para el desarrollo de aplicaciones web*. España: Díaz de Santos.
- [10] electronilab. (31 de Marzo de 2015). <http://electronilab.co/tienda/sensor-de-distancia-de-ultrasonido-hc-sr04/>. Obtenido de electronilab: <http://electronilab.co/tienda/sensor-de-distancia-de-ultrasonido-hc-sr04/>
- [11] España, M. (2003). *Servicios Avanzados de Telecomunicaciones*. España: Diaz de Santos.
- [12] FerrocarrilesEcuador. (8 de Abril de 2015). Dimensiones Locomotora a Vapor. (L.S, Entrevistador)
- [13] Flotante, P. (7 de Junio de 20015). *Mini Core SIM900*. Obtenido de <http://www.puntoflotante.net/MINI-CORE-SIM900-GSM-GPRS-QUAD-BAND.htm>
- [14] FREAKS, E. (5 de Junio de 2015). *Ultrasonic Ranging Module HC-SR04*. Obtenido de <http://www.micropik.com/PDF/HCSR04.pdf>
- [15] Garcia, P., Hidalgo, M., & Muñoz, J. (2013). *Practicas con ARDUINO*. EDUBASICA.
- [16] Harri Holma, A. T. (2006). *HSDPA/HSUPA fo UMTS*. Inglaterra: WILEY.
- [17] Heurtel, O. (2011). *PHP 5.3: Desarrollar un sitio web dinamico e interactivo*. Barcelona - España: ENI.
- [19] Heurtel, O. (2014). *PHP5.5: Desarrollo de un sitio web dinámico e interactivo*. Barcelona: Recursos Informáticos.
- [20] Mora, S. L. (2001). *Programación en Internet: Clientes WEB*. España: Universidad de Alicante.
- [21] Moya, J. M. (2006). *Redes y Servicios de Telecomunicaciones*. Paraninfo.
- [22] Sharma, V. (10 de Junio de 2015). *TCP Connection over GPRS using SIM900 and AT Commands*. Obtenido de TCP Connection over GPRS using SIM900 and AT Commands: <https://vsblogs.wordpress.com/2013/11/28/tcp-connection-over-gprs-using-sim900-and-at-commands/>



Edison S. Lucero L.

He was born in Cayambe, Pichincha province on January 8, 1990. He studied at school, "Nelson Torres" getting the degree in the specialty of Physical Mathematician in the town of Cayambe.

He is currently a graduate of the School of Engineering in Electronics and Communication Networks of the Técnica del Norte University of the city of Ibarra.