

26	2	Soporte tolva	DVTO-0002-01	
25	1	Protección estructura	DVES-0025	
24	1	Eje motor 2	DVEJ-0024	
23	1	Eje motor 1	DVEJ-0023	
22	2	Engranajes eje motor	DVEN-0022	3,5M MT 20PA 15FW
21	2	Engranajes	DVEN-0021	KSB1414-2M-32N1-0A-32
20	4	Rodamiento bocin	DVRO-0020	AFBMA 20,1-23-15-8
19	2	Eje desplazamiento	DVEJ-0019	
18	2	Bocin eje	DVEJ-0018	
17	1	Base mordaza	DVSE-0017	
16	1	Sellado derecha izquierda	DVSE-0016	
15	1	Apoyo derecho/izquierdo	DVSE-0015	
14	1	Guia mordaza	DVSE-0014	
13	1	Base pistón	DVSE-0013	
12	1	Mordaza izquierda	DVSE-0012	
11	1	Mordaza derecha	DVSE-0011	
10	1	Tubo descarga	DVTD-0010	
9	1	Unión tubo boquilla	DVTB-0009	
8	1	Boquilla descarga	DVBD-0008	
7	4	Vaso	DVVA-0007	
6	1	Plato fijo	DVPL-0006	
5	1	Plato porta vasos	DVPL-0005	
4	1	Eje plato dosificador	DVPL-0004	
3	1	Caida tolva	DVTO-0003	
2	1	Tolva	DVTO-0002	
1	1	Estructura	DVES-0001	
No. de orden	No. de pieza	DENOMINACIÓN	N. DE NORMA O DIBUJO	OBSERVACIONES
			Tolerancia	(Peso)
			Fecha	Nombre
		Dib.	08/07/2017	Chuquin C.
		Rev.	08/07/2017	Erazo V.
		Apro.	10/07/2017	Erazo V.
Edi- ción	Modifi- cación	Fecha	Nombre	
				ESCALA
				DOSIFICADORA VOLUMÉTRICA
				1:20
				CIME-0101
				UTN

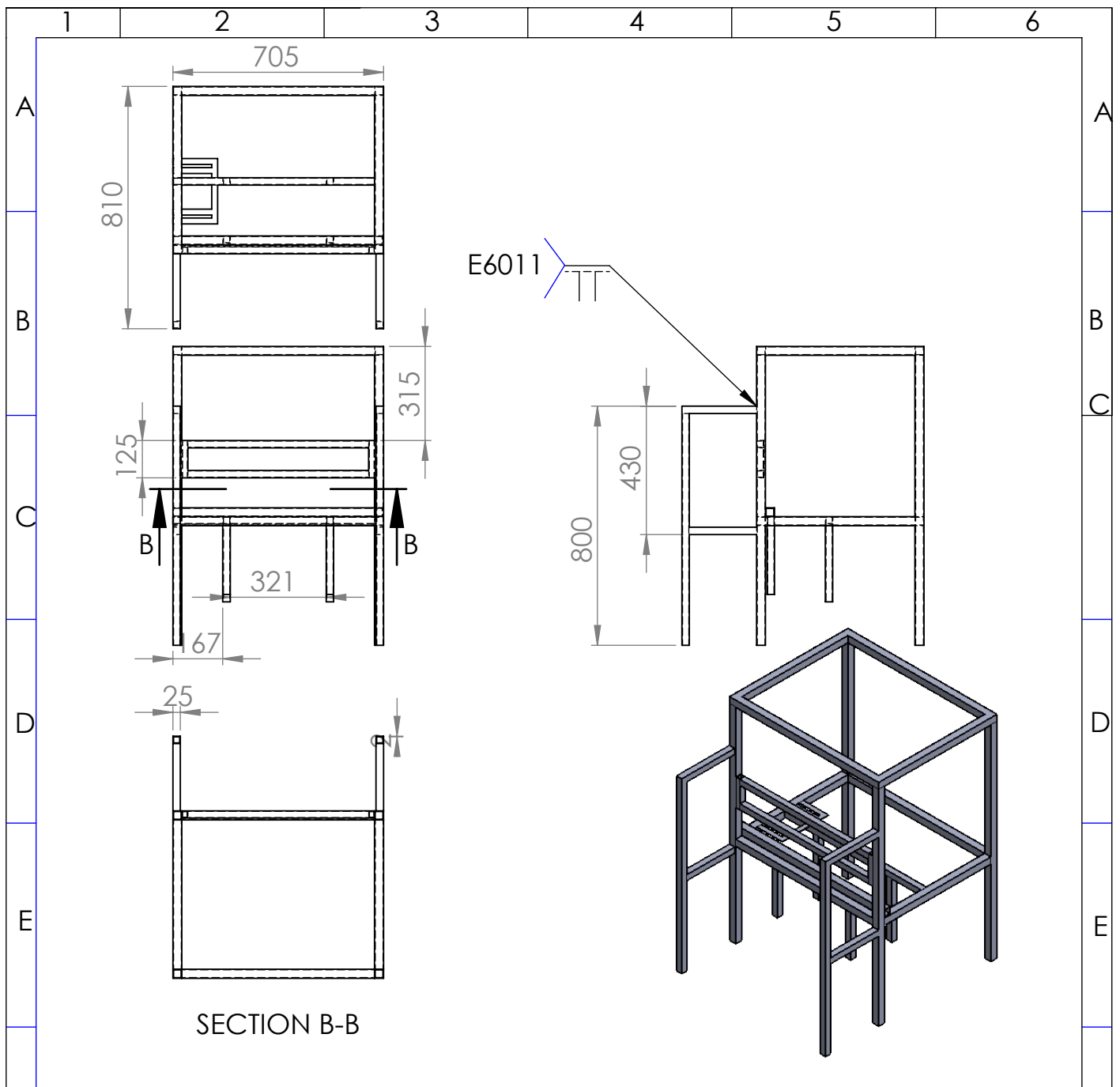

SECTION B-B

	2	TUBO ESTRUCTURAL MECÁNICO	AISI 1020	705X30X2MM
	2	TUBO ESTRUCTURAL MECÁNICO	AISI 1020	560X30X2MM
	4	TUBO ESTRUCTURAL MECÁNICO	AISI 1020	1000X30X2MM
	2	TUBO ESTRUCTURAL MECÁNICO	AISI 1020	500X30X2MM
	6	TUBO ESTRUCTURAL MECÁNICO	AISI 1020	645X30X2MM
	4	TUBO ESTRUCTURAL MECÁNICO	AISI 1020	250X30X2MM
	2	TUBO ESTRUCTURAL MECÁNICO	AISI 1020	800X30X2MM
	4	TUBO ESTRUCTURAL MECÁNICO	AISI 1020	260X30X2MM
	4	PLATINA	AISI 1020	120X20X2MM
	1	PLATINA	AISI 1020	220X20X2MM

No. de orden	No. de pieza	DENOMINACIÓN	N. DE NORMA O DIBUJO	OBSERVACIONES			
			Tolerancia +/-0.5mm	(Peso) 20Kg			
				AISI 1020			
			Dib.	Fecha			
			08/07/2017	Nombre			
			Chuquin C.	ESTRUCTURA	Escala 1:20		
			Rev.			08/07/2017	Erazo V.
			Apro.			10/07/2017	Erazo V.
				DVES-0001	UTN		
Edición	Modificación	Fecha	Nombre				

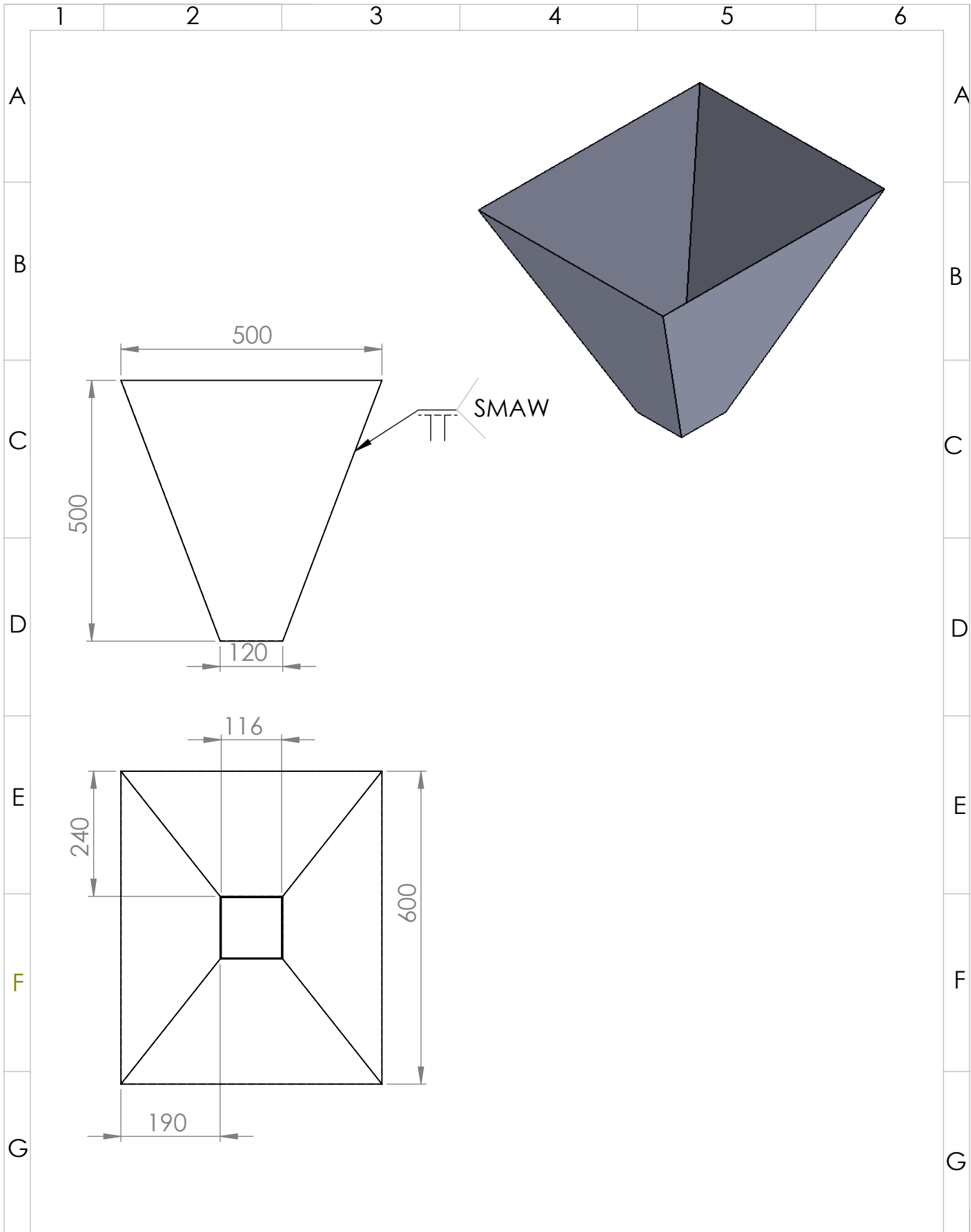

				Tolerancia	(Peso)	AISI 304		
						TOLVA	Escala	
				Dib.	Fecha		Nombre	1:10
				Rev.	08/07/2017		Erazo V.	
				Apro.	10/07/2017		Erazo V.	
Edición	Modificación	Fecha	Nombre				DVTO-0002	UTN

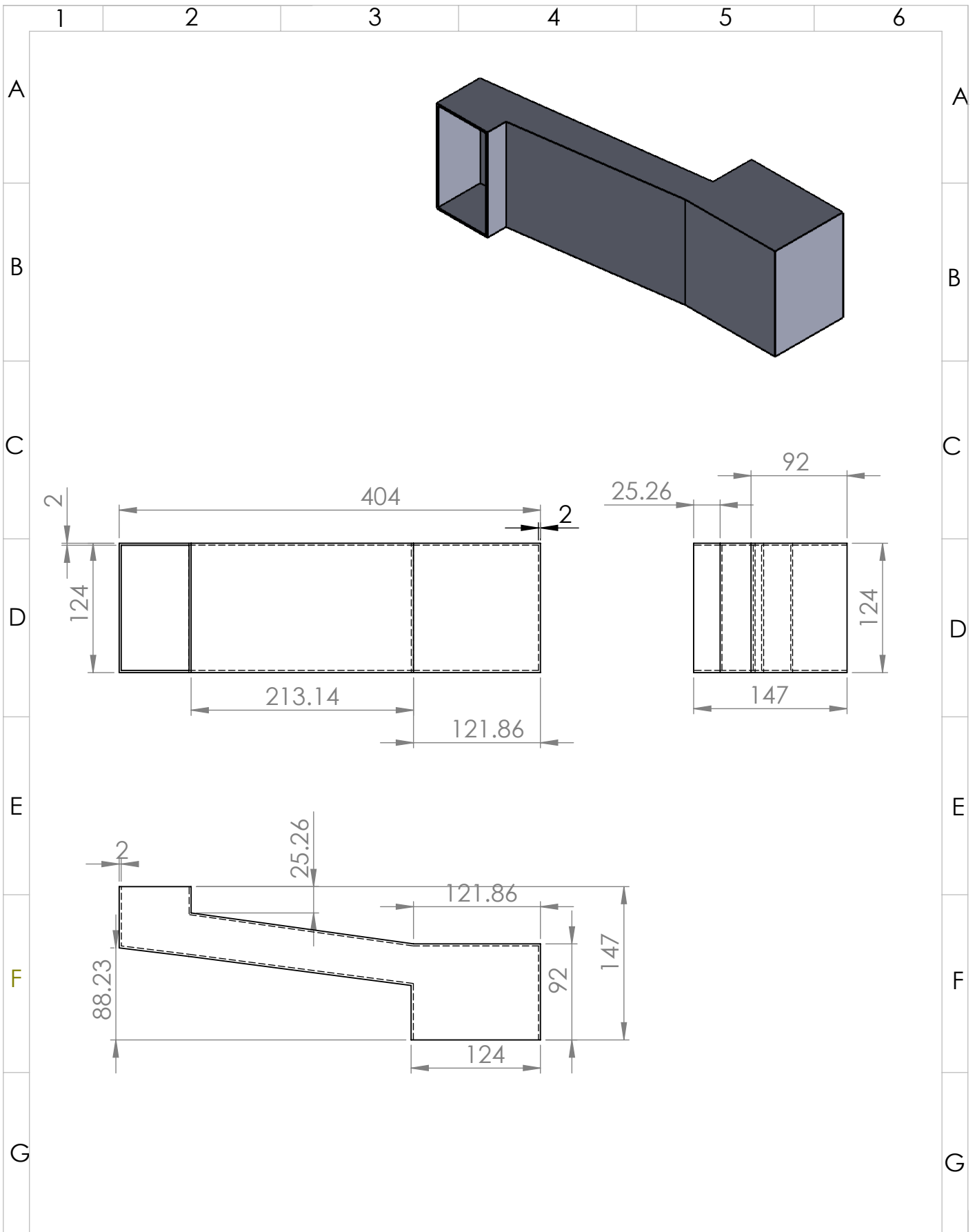

				Tolerancia	(Peso)	AISI 304	
						CAIDA TOLVA	
				Fecha	Nombre	Escala	
				Dib.	08/07/2017	Chuquin C.	1:5
				Rev.	08/07/2017	Erazo V.	
				Apro.	10/07/2017	Erazo V.	
				DVTO-0003			UTN
Edición	Modificación	Fecha	Nombre				

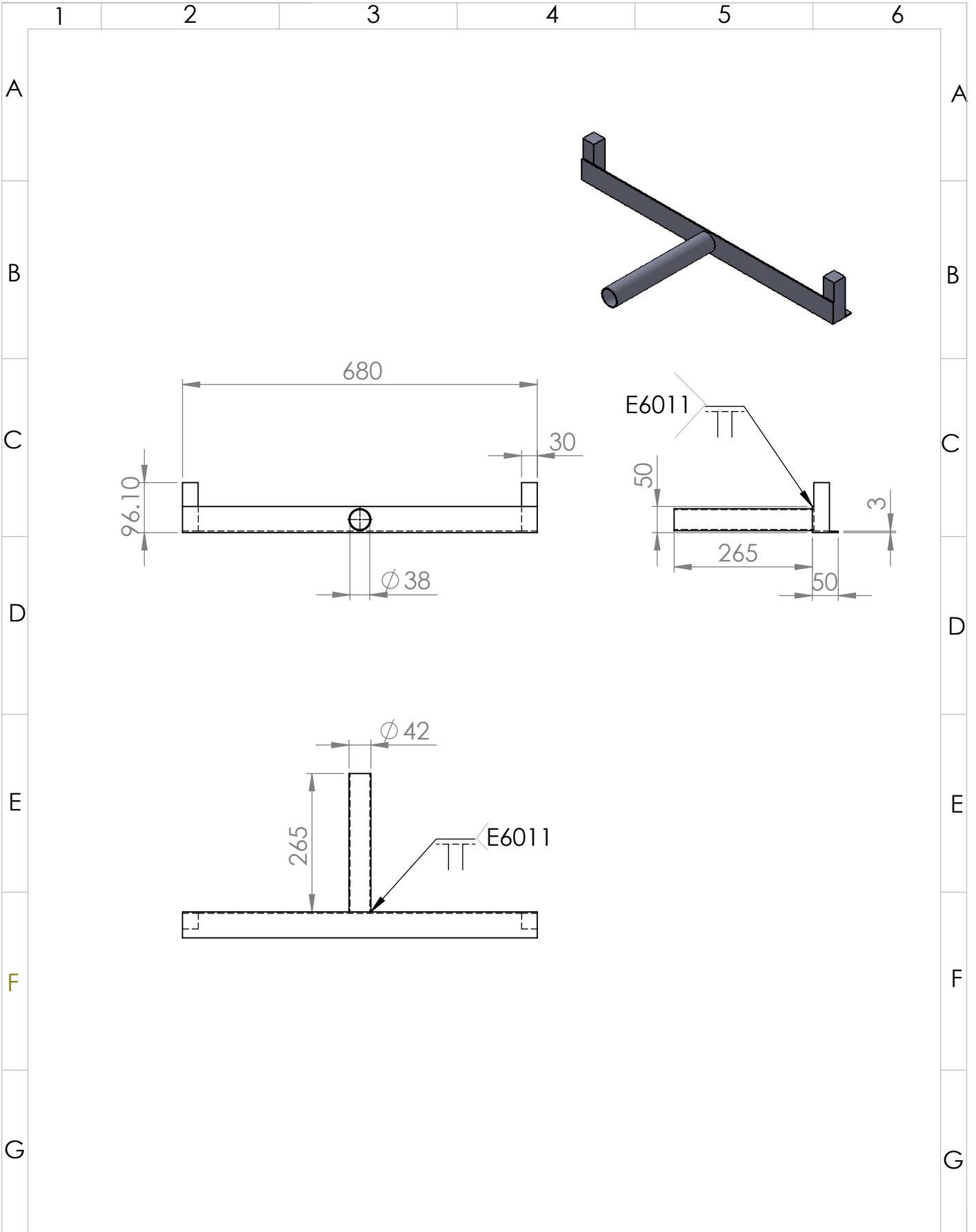

				Tolerancia	(Peso)	AISI 1045		
						Eje plato dosificador	Escala	
				Fecha	Nombre		1:10	
				Dib.	08/07/2017			Chuquin C.
				Rev.	08/07/2017			Eraza V.
				Apro.	10/07/2017	Eraza V.		
				DVPL-0004			UTN	
Edición	Modificación	Fecha	Nombre					

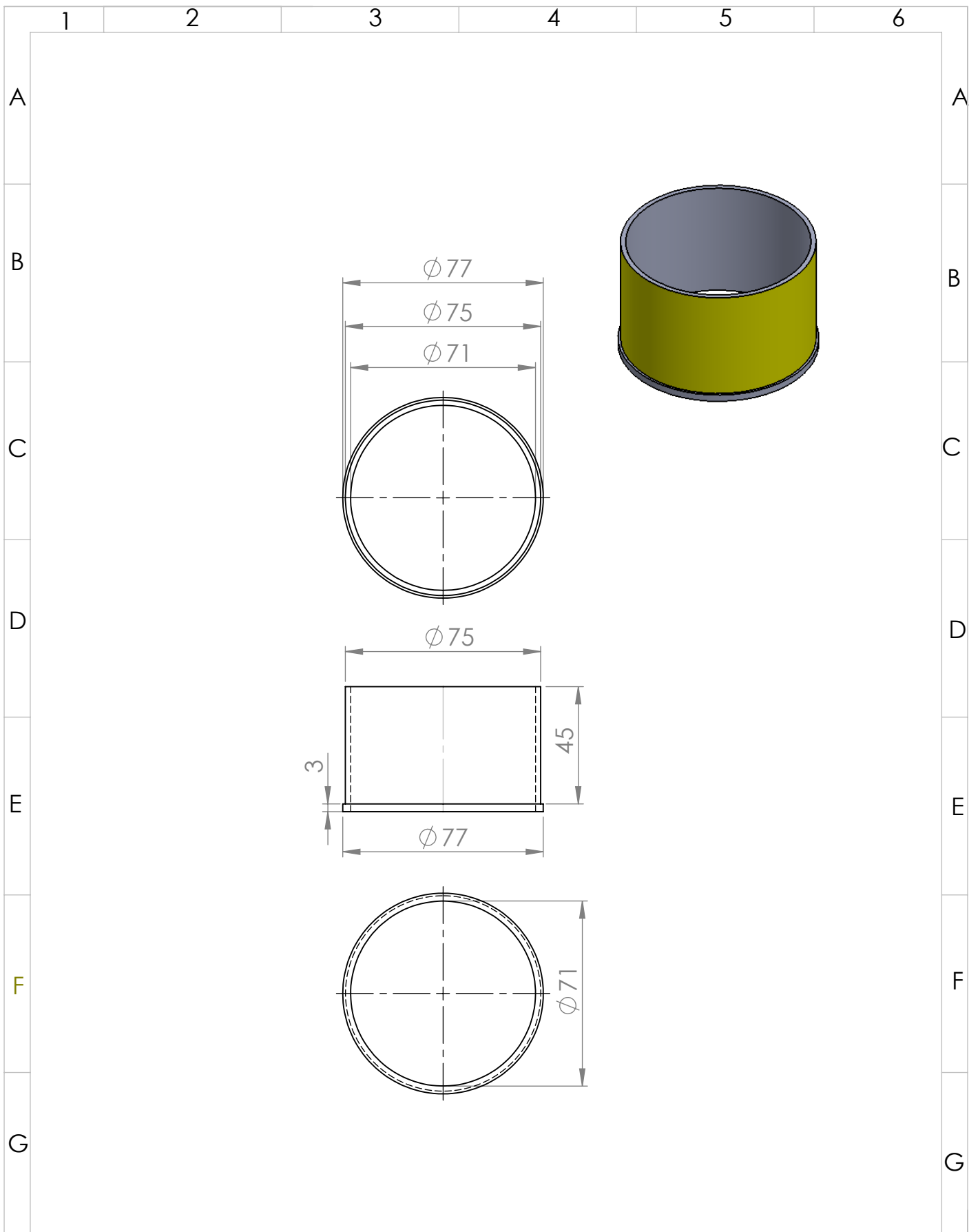

				Tolerancia	(Peso)	NYLON		
						VASO	Escala	
				Dib.	Fecha		Nombre	1:2
				Rev.	08/07/2017		Erazo V.	
				Apro.	10/07/2017		Erazo V.	
						DVVA-0007	UTN	
Edición	Modificación	Fecha	Nombre					

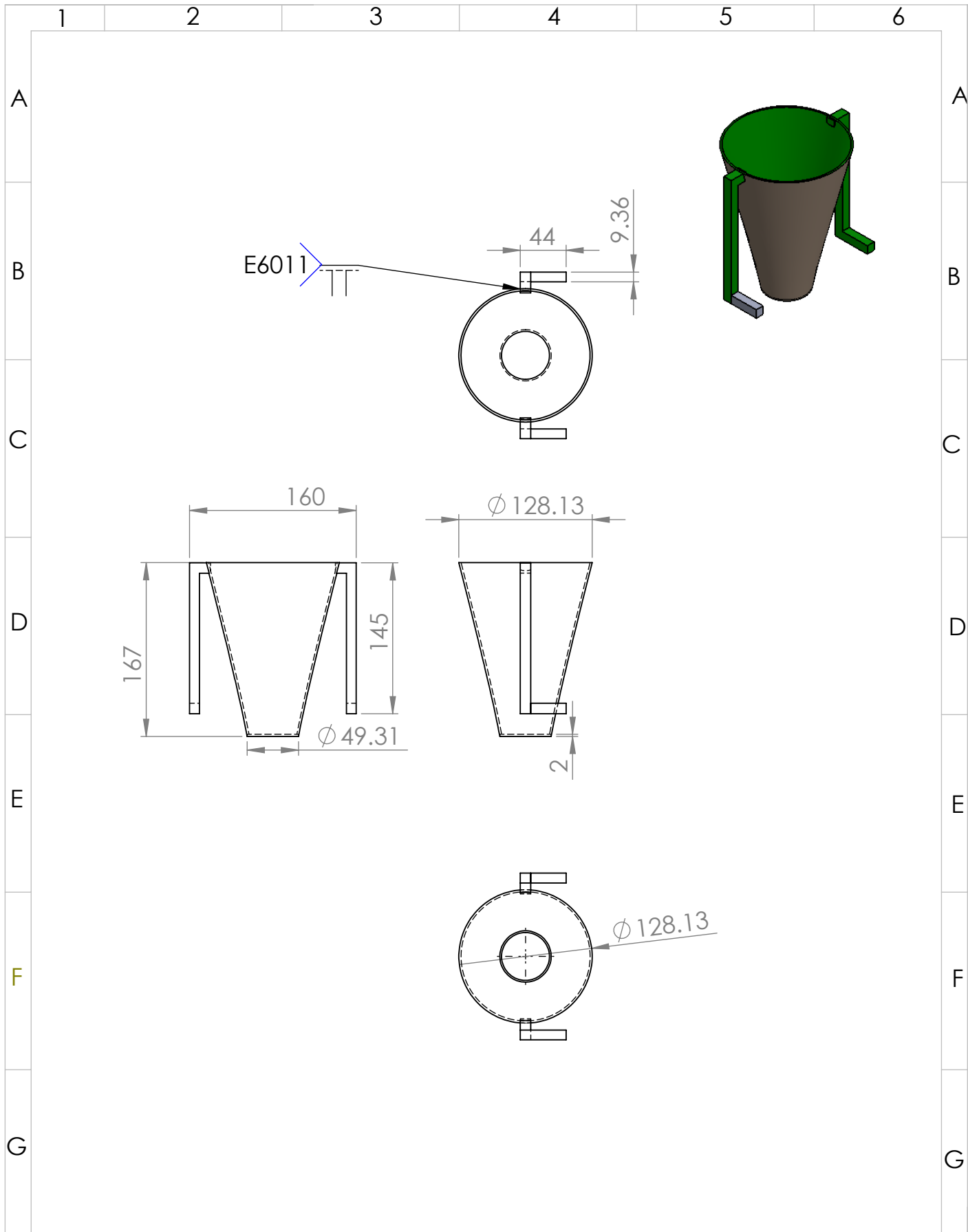

				Tolerancia	(Peso)	AISI 1045	
				Fecha	Nombre	BOQUILLA DESCARGA	
				Dib.	08/07/2017	Chuquin C.	Escala
				Rev.	08/07/2017	Erazo V.	1:5
				Apro.	10/07/2017	Erazo V.	UTN
Edición	Modificación	Fecha	Nombre	DVBD-0008			

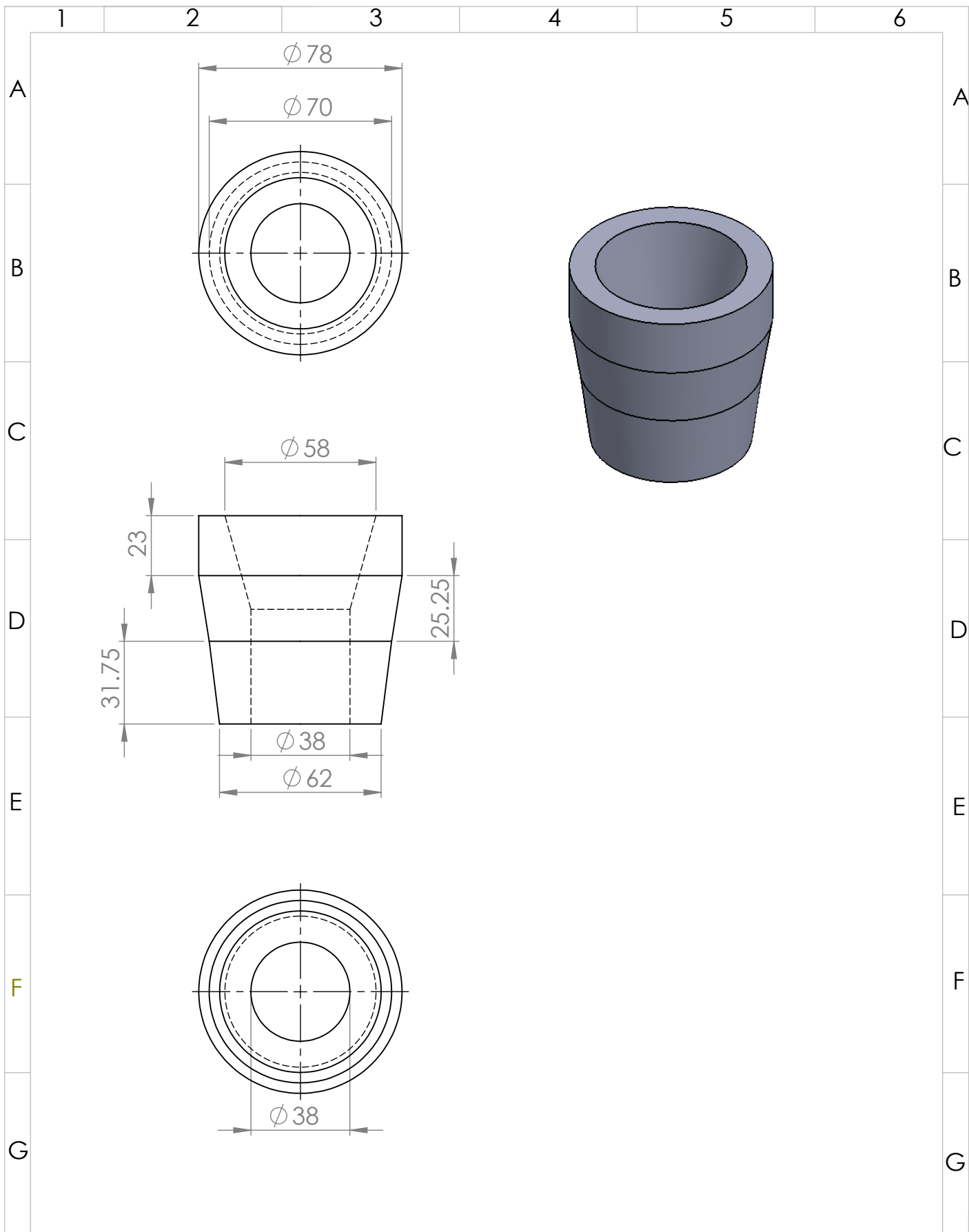

				Tolerancia	(Peso)	NYLON		
						UNIÓN TUBO BOQUILLA	Escala	
							1:5	
							DVTB-009	UTN
Edición	Modificación	Fecha	Nombre					
				Dib.	08/07/2017	Chuquin C.		
				Rev.	08/07/2017	Erazo V.		
				Apro.	10/07/2017	Erazo V.		

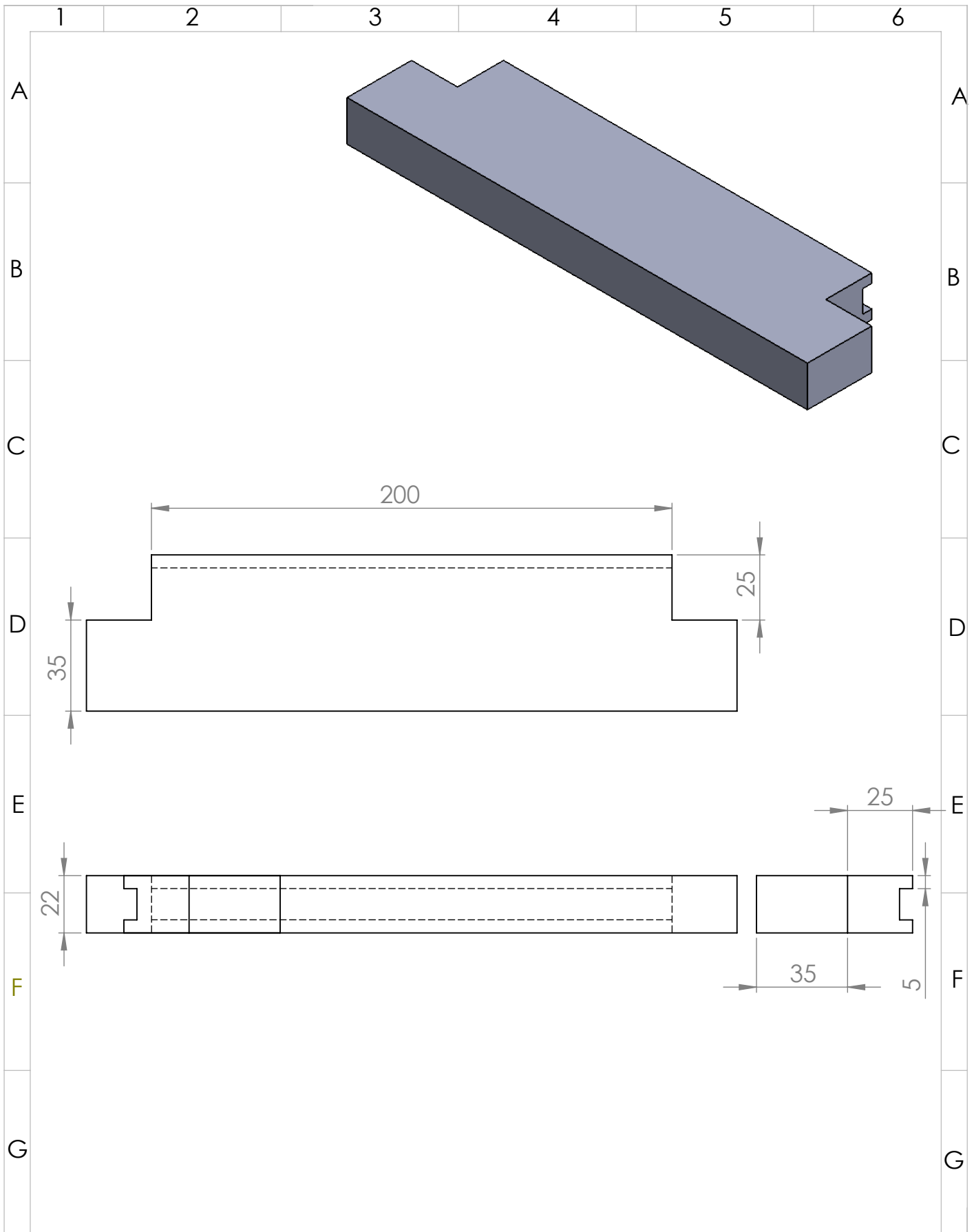

				Tolerancia	(Peso)	ALUMINIO DE FUNDICIÓN		
				Fecha	Nombre	SELLADO DERECHA IZQUIERDA	Escala	
				Dib.	08/07/2017		Chuquin C.	1:2
				Rev.	08/07/2017		Erazo V.	
				Apro.	10/07/2017	Erazo V.	UTN	
Edición	Modificación	Fecha	Nombre	DVSE-0016				

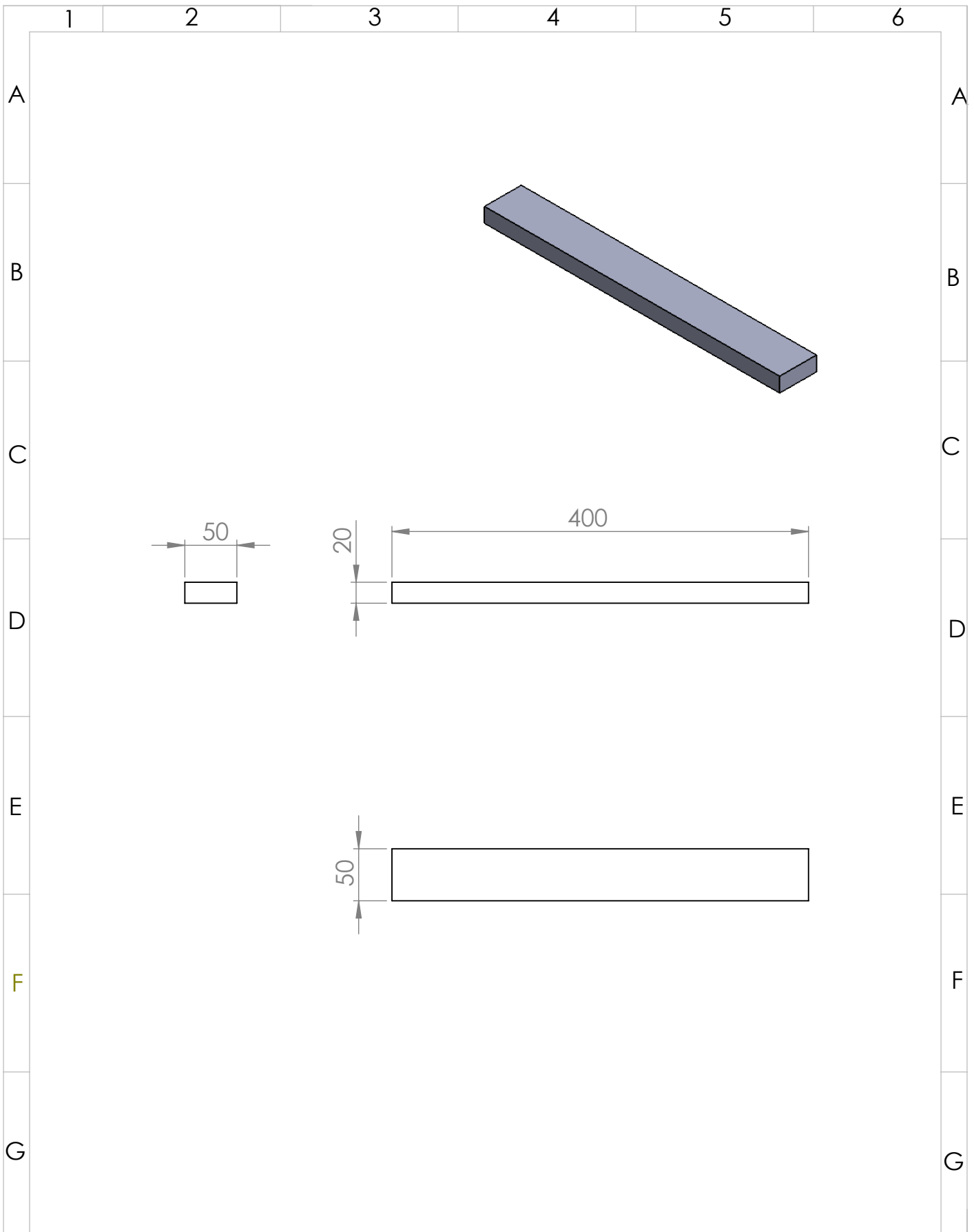

				Tolerancia	(Peso)	ALUMINIO DE FUNDICIÓN		
						Base mordaza	Escala	
				Dib.	Fecha		Nombre	1:5
				Rev.	08/07/2017		Chuquin C.	
				Apro.	10/07/2017	Erazo V.	UTN	
						DVSE-0017		
Edición	Modificación	Fecha	Nombre					

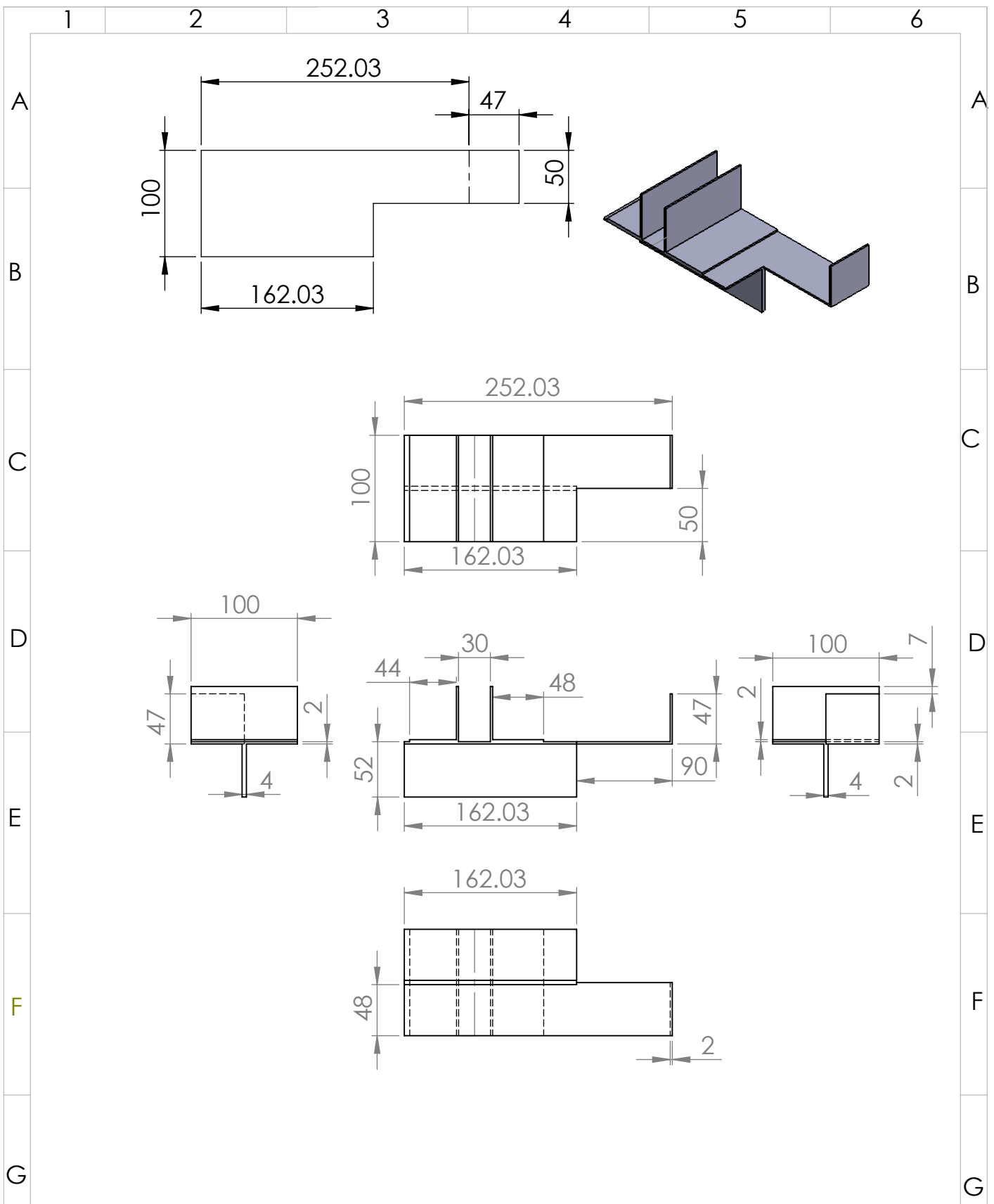

1		AL 40 x 3mm		ASTM A36		AL 40X40X3 mm	
No. de orden	No. de pieza	DENOMINACIÓN		N. DE NORMA O DIBUJO		OBSERVACIONES	
			Tolerancia	(Peso)	AISI 1045		
					MORDAZA DERECHA		
					1:5		
					DVSE-0011		
					UTN		
Edición	Modificación	Fecha	Nombre	Fecha	Nombre	Escala	
				Dib.	08/07/2017	Chuquin C.	1:5
				Rev.	08/07/2017	Erazo V.	
				Apro.	10/07/2017	Erazo V.	

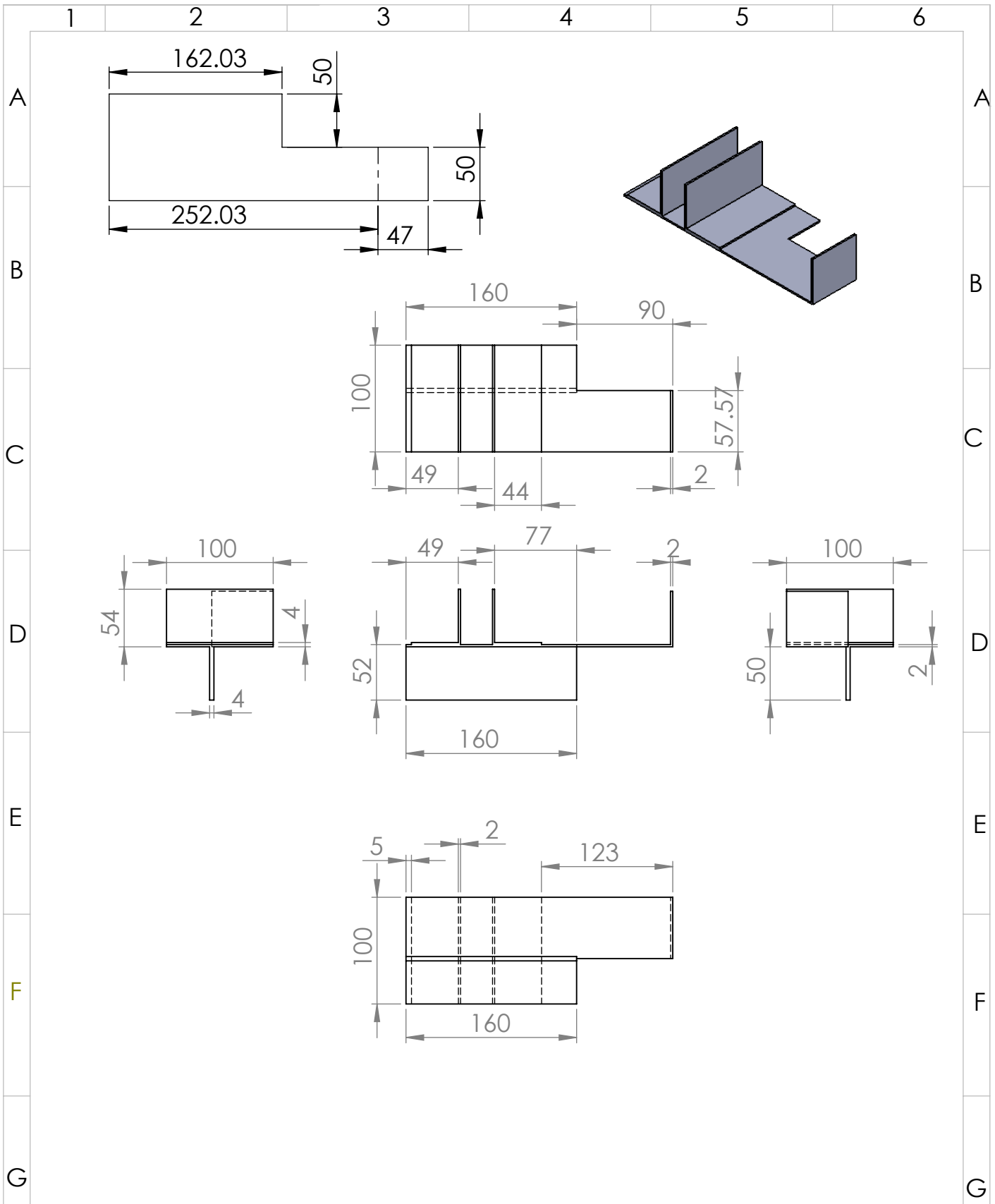

1		AL 40 x 3mm		ASTM A36		AL 40X40X3 mm	
No. de orden	No. de pieza	DENOMINACIÓN		N. DE NORMA O DIBUJO		OBSERVACIONES	
		Tolerancia		(Peso)		AISI 1045	
			Fecha	Nombre		Escala	
		Dib.	08/07/2017	Chuquin C.		1:5	
		Rev.	08/07/2017	Erazo V.			
		Apro.	10/07/2017	Erazo V.			
						UTN	
Edición	Modificación	Fecha	Nombre		DVSE-0012		

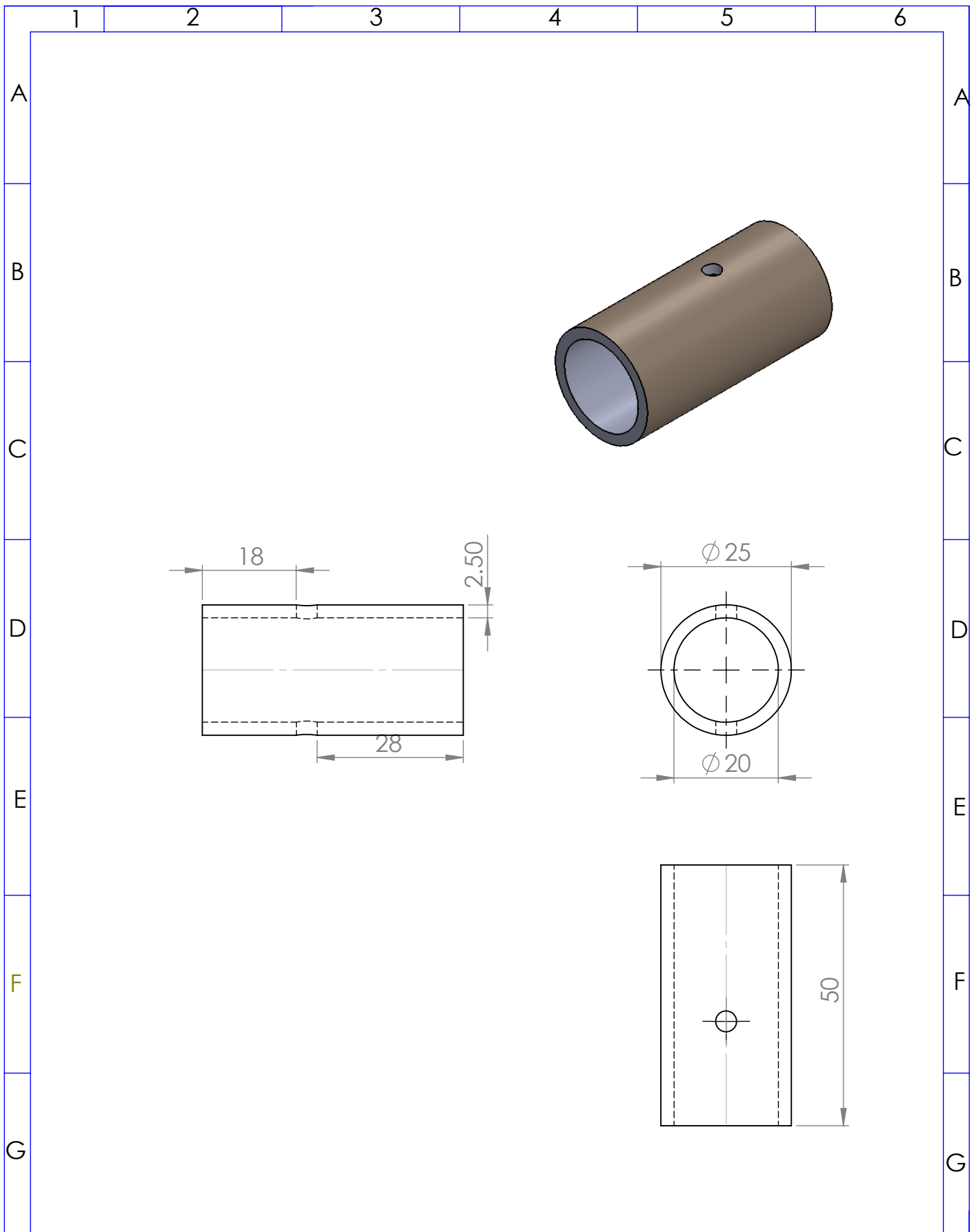

				Tolerancia	(Peso)	AISI 1045		
						EJE MOTOR 2	Escala	
							1:1	
				Dib.	08/07/2017		Chuquin C.	
				Rev.	08/07/2017		Erazo V.	
				Apro.	10/07/2017	Erazo V.		
						DVEJ-0024		
Edi- ción	Modifi- cación	Fecha	Nombre				UTN	

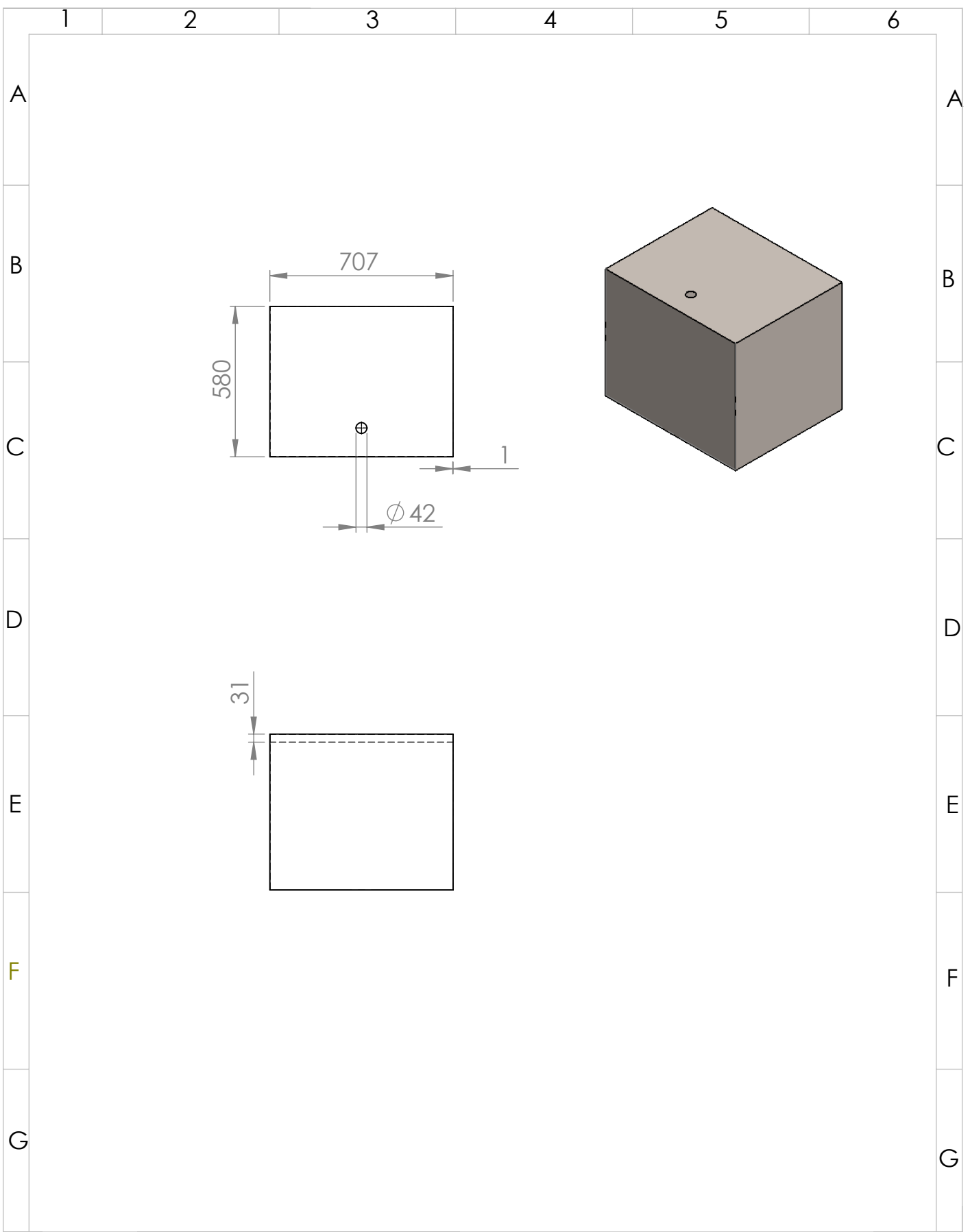

				Tolerancia	(Peso)	AISI 304	
						PROTECCIÓN ESTRUCTURA DVES-0025	Escala
				Fecha	Nombre		1:20
				Dib. 08/07/2017	Chuquin C.		
				Rev. 08/07/2017	Erazo V.		
				Apro. 10/07/2017	Erazo V.		
Edición	Modificación	Fecha	Nombre				UTN

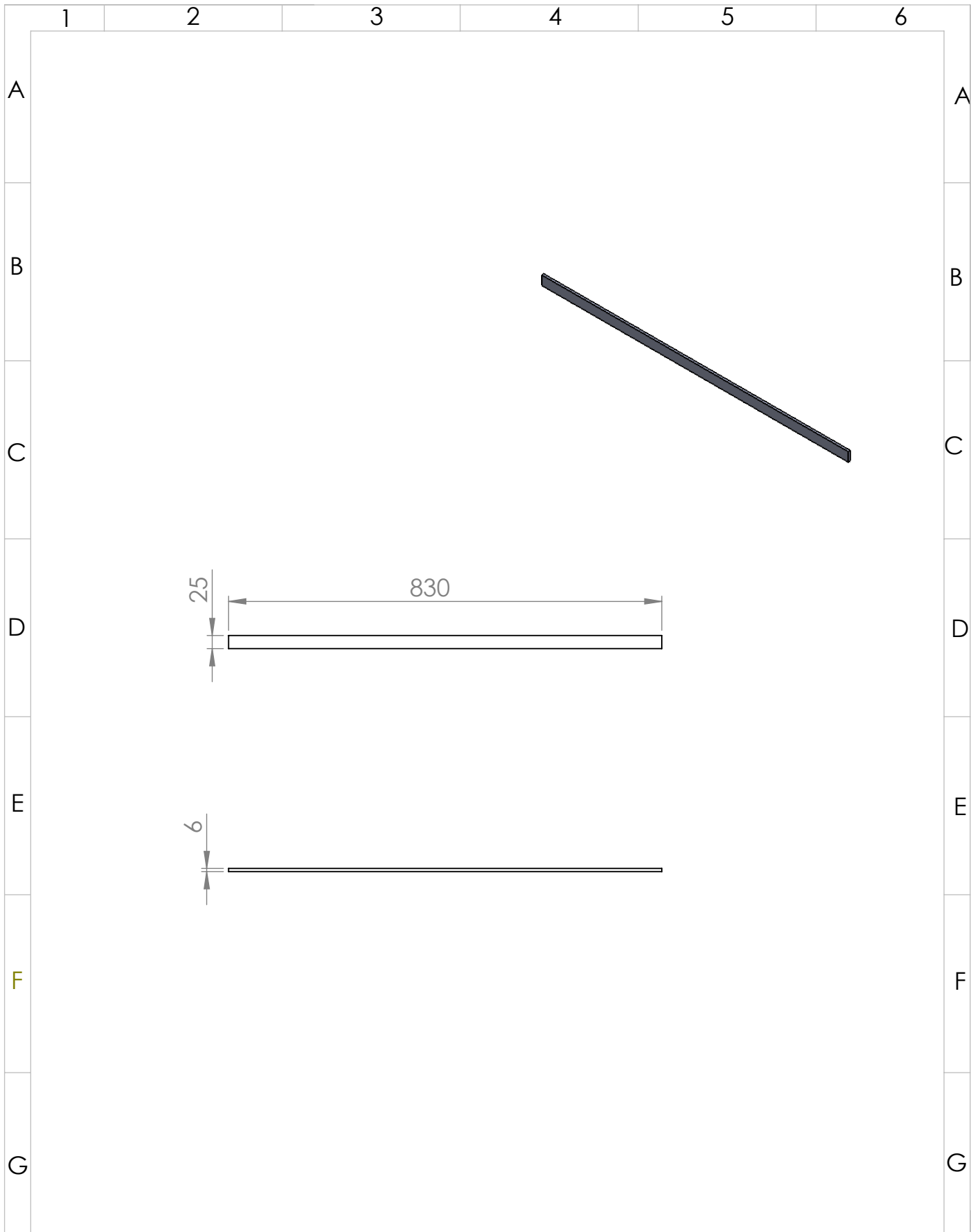

				Tolerancia	(Peso)	AISI 304	
					Fecha	Nombre	Escala
				Dib.	08/07/2017	Chuquin C.	1:10
				Rev.	08/07/2017	Erazo V.	
				Apro.	10/07/2017	Erazo V.	
						DVTO-0002-01	
Edición	Modificación	Fecha	Nombre			UTN	