



TÉCNICA DEL NORTE COLLEGE



ENGINEERING OF APPLIED SCIENCE SCHOOL

MAJOR OF ENGINEERING IN MECATRÓNICA

SCIENTIFIC ARTICLE

SUBJECT

**“CARROT SEED DRILL MACHINE TO OPTIMIZE THE
DISTRIBUTION OF SEED”**

AUTOR:

Geovanny Alexander Chiriboga Ibujés

Ibarra – Ecuador

December 2015

CARROT SEED DRILL MACHINE TO OPTIMIZE THE DISTRIBUTION OF SEED

Sr. Chiriboga Ibujés Geovanny Alexander¹ Ing. Arias Collaguazo Octavio German²
Faculty of Engineering in Applied Science, Técnica del Norte Collage, Ibarra, Ecuador
shoshounico@yahoo.es, cga@utn.edu.ec

Abstract. – *The present project contemplates design and construction the machine carrot seed drill to optimize the distribution of seed.*

Today is always looking for quality food, as natural as possible and to achieve this we must start from the correct spread of the plant so that adequate time will not affect development in both volume and appearance.

Using the drill go down production costs, this advantage adds to that exists in the small area farms that would adapt to the use and benefit of this machine. The design and construction is positively related with respect to qualified zone as usual and that are being planted crop in a high percentage; this is one of the most important reasons that justify the creation of work and development of the planter.

On data taken in planting carrot it can be determined that in eight hours are planted with at least seven people a total of 100 m² being a very low work. With the implementation of this control system on the seed drill is to reach at least an increase of 200% ie the same time used to plant twice as stated above.

Parallel is important to note that there are no companies for the construction of these machines and their import entails drawbacks in maintenance, repair and purchase of spare parts in the domestic market in Ecuador. This project aims to solve these problems.

Work on developing a study of design alternatives machines used for this process, followed by selection of the most viable option according to certain established parameters is presented.

Keywords

Planter of carrot, vegetable seed, structure of the machine, mechanical dispenser, carrot, hopper design.

1. Introduction

The carrot is a very popular product both for its high content of beta carotene, the precursor of vitamin A, as well as being a source of vitamins and minerals, you need a good preparation ground from a depth of 25-30 cm good water infiltration, aeration of soil and weed control, sowing is done manually, so that in one way or another achieved the goal of planting.

Currently carrot planting is done by hand using a stake of at boleto or planters, creating long, major

investment, it requires too much effort of individuals, factors that influence the spread of the plant.

With the construction and operation of a machine drill carrot seed distribution in addition to providing precise work will be optimized; to avoid after thinning of 2-3 cm between plants, thus achieving avoid future weed control, pest major diseases of the carrot and the system is fast, easy handling and operation of one person giving thus an largest area of planted land.

2. System Overview

Today planting carrot is a purely manual process in which a long time is used, the same as the decreased using a mechanical process affects time that can be devoted to improve another stage of benefit, such as irrigation.

To make the design of the planter of carrot, should be established:

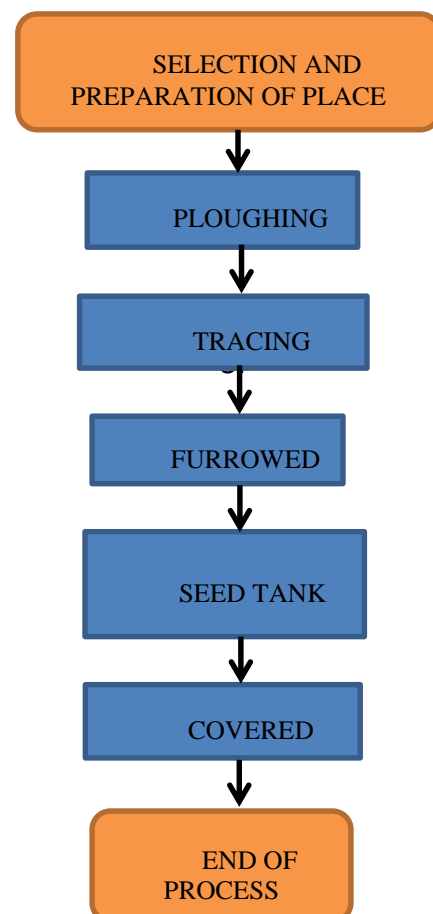

Figure 1: Flow chart of the process of planting carrot

2.1 Planting depth

Planting depth should be adapted to soil conditions. Under normal tuber growth should be between 5-10 cm maximum depth for germination can succeed without difficulty. The following figure shows the following parameters are determined:

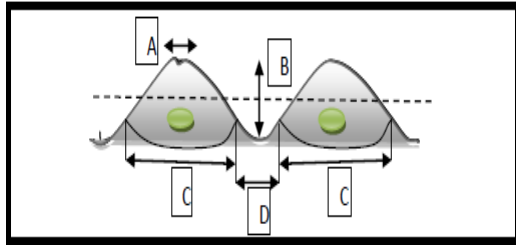

Figure 2: Length, height, diameter of the groove for planting

A = length of hungry striped groove (4-8 cm).

B = height of the groove (20 to 25 cm).

C = groove diameter (22-27 cm).

D = length of irrigation.

2.2 Seed

Quantity: 500,000 x tin seeds.

Direct seeding: 4-8 kg.

Seeds per gram: 800-1200.

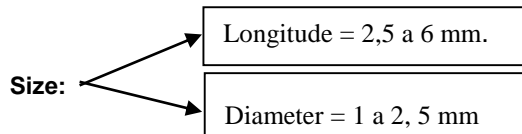

2.3 Formulation of alternatives

The alternatives presented below are the result of some ideas originated in the field study and are determined based on the design parameters and functions listed above.

Table 1: Features input (compacted soil)

HALL: FLOOR		
INPUT VARIABLES	LIMITATIONS OF ENTRY	CONDITION
Soil Resistance Seed Type Wrought width Depth labarado	Not very compact grasses type Not more than 10 cm Not more than 10 cm	$\gamma_a < 1,9 \text{ gr / cm}^3$ $2,5\text{mm} \leq L \leq 6 \text{ mm}$ $a \leq 10 \text{ cm}$ $p \leq 10 \text{ cm}$

Table 2: Output characteristics (tilled soil)

OUTPUT: TILLED SOIL		
INPUT VARIABLES	LIMITATIONS OF ENTRY	CONDITION
Floor with lower apparent density than the input. Degree of coverage of the seed.	Apparent density must be less than 30%. The seed is covered between (60-90)%.	$\gamma_1 < 30 \%$ (γ_a .entrada) $\gamma_2 > (60 - 90)\% \text{ V. semilla}$

2.4 Mechanical Design of Structure and Mechanisms

We describe the design, structure and mechanisms of the machine taking into account the above conditions. The optimum efficiency of the drill depend on some aspects such as: the type of terrain, weather conditions where planting took place, the type of materials used for its construction.

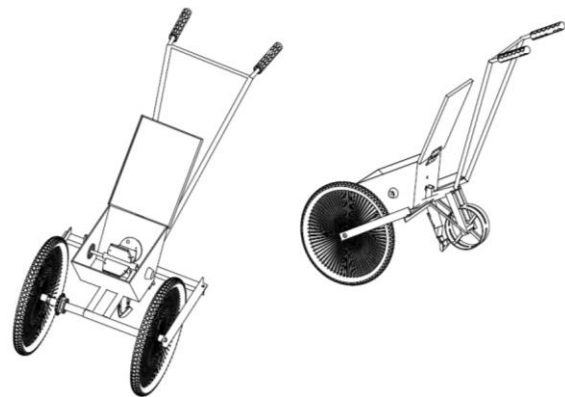

Figure 3: Design carrot seed drill

2.5.1 Design Opener

It is the part with which the scratch is made in the groove for depositing seeds traveling from the hopper via the conduit to the surface.

It is a grid size Steel ASTM A-36 as a boot, at the top has an opening for delimiting to height or depth choose the farmer to go seed or in this case the hatching and in its lower part is reinforced by the inner part to break ground and open the groove.

When the tip of the grille wearing both plowing, are the fans in the forge, if the deterioration is so



exaggerated that it falls short is supplemented with a piece of iron and is given the required shape.

The grille wears more or less because of the time are, but according to the type of soil.

This is fixed to the outlet pipe via a threaded screw - metal DIN 84 M3.5 and the other end by a flat washer DIN 9021 M6 and M16 hexagonal nut DIN 6915 for more tightening there.

The calculations are:

- ✓ Soil resistance to blade:

$$M = F_c + F_a + F_f \text{ [kgf]}$$

- ✓ Calculation of cutting force:

$$F_c = C_s \times b \text{ [kgf]}$$

- ✓ Calculation of the acceleration force:

$$F_a = m \times a = \frac{G}{g} \times a \text{ [kgf]}$$

- ✓ Proportion of land cut by the knife:

$$G = V_m \times d \times b \times w \text{ [kgf]}$$

- ✓ Time in which the opener passes through the cutting area:

$$t = \frac{\lambda_1}{2\pi} \text{ [s]}$$

- ✓ Acceleration:

$$a = \frac{V_c}{t} \left[\frac{m}{s^2} \right]$$

- ✓ Calculation of the friction force:

$$F_f = F_c \times C_f \text{ [kgf]}$$

$$F_f = V_m \times d \times b \times w \times C_f \text{ [kgf]}$$

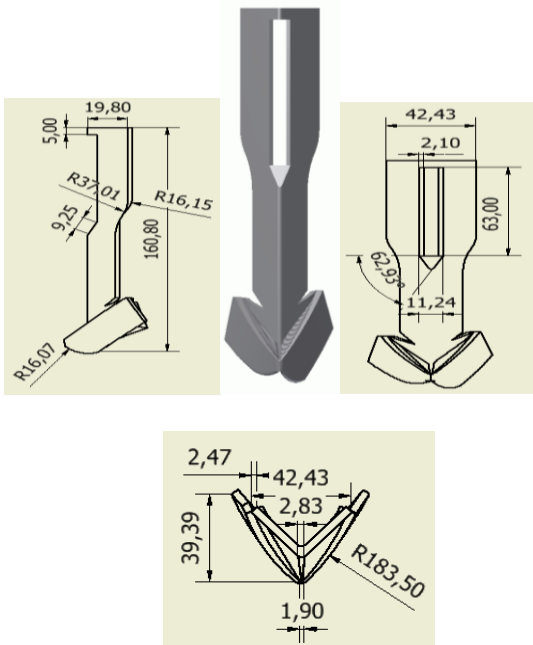

Figure 4: Design openers

2.6 Performed Tests

In this section we consider the tests to be performed to ensure correct operation of the drill

machine carrot once built them to certify that the machine operates under optimal conditions.

The tests to be performed are:

2.6.1 Vacuum the work Carrot Seed

Normal operation of the drill carrot no load that is seeded verified.

Table 3: Dry running of the planter of carrot

Tiempo (min)	Bastidor		Tolva		Cubre Tolva		Dosificador		Órgano de Distribución		Tren Cinemático		Abresurcos	
	falla	no falla	falla	no falla	falla	no falla	falla	no falla	falla	no falla	falla	no falla	falla	no falla
5		x		x		x		x		x		x		x
10		x		x		x		x		x		x		x
15		x		x		x		x		x		x		x
20		x		x		x		x		x		x		x

2.6.2 Charging Working with Carrot Seed

In this test the capacity and quality of the sowing machine is verified.

Table 4: Working with drill burden of carrot

NUMBER OF SEEDS PER METER (m)	DIAMETER OF THE HOLES (φ)			
	Orifice 1 (2mm)	Orifice 2 (4 mm)	Orifice 3 (6 mm)	Orifice 4 (14 mm)
1	58	124	189	450
2	121	256	386	906
3	184	386	572	1354
4	238	504	765	1809
5	294	627	954	2296

2.6.3 Analysis of Results

Here we analyze what are the drawbacks encountered when work was carried out in vacuum and work load are sowing carrot.

When the work was done in vacuum planter of carrot the different parts which is constituted as is the case here hopper there were no problems because the design limit was stored inside the amount of 1.5 were analyzed kg and this parameter exceeds this, in the case of the frame as the forces exerted do not exceed the material strength abresuros existing friction between the earth and is extremely inferior allowing optimum performance, if the kinematic train at first I could not make the breakthrough machine because the part that make the wheels to the frame were extremely tight, the



machine motion was made and this when he was on land with difficulties as lumps or remaining weeds tended to move around assembly so re-adjust the tires leaving a game of movement between them if one failed the vibration it generates only stays in the part that occurs and not affecting the rest of the system, just as the body distribution works without any changes since it is securely attached to the chain rotate circularly accessing the weight of the seed, as it is directly proportional to the system if this machine the seed comes out moves.

The covering seed at first was a tire but it was very heavy, so that the grooves remain deleted, did not identify where he was the seed and did not allow the passage of water to germinate, the change was this do it in a circular but with a thickness of 6 mm capping but then performed maintaining the initial shape of the groove.

Finally so that no future problems should perform preventive maintenance consisting of grease all parts where the axes are and chain, verify if wear of the bristles of the dispenser is in perfect condition or else make the change because they can not push enough seed for these.

2.7 Conclusions

Through a field study was conducted for a year could determine the existing methods of planting more common carrot are the boleto, a stake of hand and planters. In these processes the economic value is very high because the workers involved food (breakfast, lunch), transportation thereof and payment of labor.

The carrot seed drill has a yield of 200% because it was designed and built to plant 1.5 kg (3.3 pounds of seed) in two hours and forty minutes therefore doubles the amount of land at the same time and with only a person who handled thanks to the design parameters that were taken into account such as that should not be burning energy consumption, easy maintenance and operation.

For the design of the drill machine is based on all ISO 4254 standards which manifest the materials used for its construction, likewise using Autodesk Inventor Professional 2014 software with tools stress analysis and structural parts are analyzed that They contain

critical parts such as in the case of the metering shaft with a maximum safety factor of 5.34; in the case of the opener by design criteria Goodman a safety factor of 14.71 was obtained; pusharms machine will undergo a displacement yielding a maximum of 0.02043 mm and a minimum of 0 mm by calculation by the von Mises stress, for casting a safety factor of 8.13 by the design criteria Goodman understanding that has a high degree of reliability and resistance factor is 8.45 maximum welding using E6011 electrode so it is resistant to this application.

In the construction should take into account the 11.5 mm diameter shaft dispenser for selection of bearings that go inside the hopper because they are fastened and greased for durability, another factor to consider is in the construction of the openers on the side of the inclination of the fence is 183.5° and 1.9 mm in diameter because it is the essence of striped, if larger diameter erase the groove and leftovers accumulate weed land as a forward speed collide and they would accumulate on one another impeding optimal performance of the machine, of course not always happen often but depends on the surface where it is working. The machine can be used not only to plant carrot seeds but also are within the limits of the diameters of the metering these can be, cabbage, radish, beetroot, lettuce etc.

In verification testing and calibration appeared some inconvenience as follows: if the tires are extremely tight to frame the system becomes one, when in unfavorable planting conditions that a wheel clash with impurities the reaction which occurs is the machine jumping preventing continuous scratch, so that trial tests gave better result there is a play between shaft - tire and the drawback is obviated.

2.6 Recommendations

For optimum seed germination of carrot influence different factors such as, the soil surface, preparation of organic and inorganic nutrients, include the speed with which the operator performs planting, the diameter output select seed, these are factors which depends germination.

It is recommended to calibrate the dispenser according to the amount of seed output required by the



farmer as it is an arbitrary system that is it depends on the owner, if the marketing or feeding cattle.

Verify that all this distribution system coupled to the shaft so that it can rotate when the advance of the machine (kinematic train) is performed. When putting the machine into operation is advisable to review all components to verify that they are run optimally, which means lubricated bearings, well fitted and attached structure, tempered chain, etc.

According to the hours of operation of the machine, change the synthetic bristles (brushes) because there are wear caused by friction of the seed and the material hopper.

3. Bibliographic References

- [1] Faires, M. (2003). *Diseño de Elementos de Máquinas*. México: Limusa.
- [2] Parker. (2000). *Neumática Industrial*. (4ta ed.). México.
- [3] MC Cormac, Jack. (2005). *Análisis de Estructuras*. (3ra ed.). México: Prentice Hall.
- [4] Terradonis, *Sembradoras de Precisión*. ICS. La Jarrie – Francia.
- [5] Ismith, William; F. & Hashemi; Javad.(2006). *Fundamentos de La Ciencia e Ingeniería de Materiales*.(3ra ed).
- [6] Riley, William F.(1996) *Ingeniería Mecánica Estática*.
- [7] Robert L. Norton.(1999). *Diseño de Máquina*.
- [8] Fitzgerald, M. (2007) *Mecánica De Materiales*. Edición Revisada.
- [9] Caplab,(2001). *Manual de Soldadura Universal*. (2da ed).
- [10] Mir, Zinoviev, V.(2003); *Teoría de los Mecanismos*. (1era ed).
- [11] Shigley, C.R. Mische.(2002). “*Diseño en ingeniería mecánica*”. McGraw-Hill. México.
- [12] Hibbeler, R.(2003). “*Mecánica para ingenieros, Estática*”. CECSA. México.
- [13] Hibbeler , R.C.(2010). *Ingeniería Mecánica Estática*. Pearson Education.
- [14] Hibbeler, C; Rusell.(2010). *Ingeniería Mecánica Dinámica*. Pearson Education.

- [15] Wolf, John; T, & Beer, Ferdinand; P, Johnston, Jr; E, Rusell. (2010). *Mecánica de*
- [16] Goodno, Barry; & Gere, James; M.(2009). *Mecánica de Materiales*. Cengage
- [17] Millan, Gomez; Simon.(2006). *Procedimientos de Mecanizado*. Thomson.
- [18] Hesel, Jay; D, Short, & Jensen, Dennis; Cecil.(2004). *Dibujo y Diseño en Ingeniería*.
- [19] Hashemi, Smith; Javad, William.(2006). *Fundamentos de la Ciencia e Ingeniería de Materiales*. McGraw-Hill.
- [20] Krar, Steve; F., & Gill, Arthur. (2009). *Tecnología de las Maquinas Herramientas*.

4. Articles

- [21] Gaínza, Jose; Pérez De Ciriza, Jesús. (2003). *La Sembradora de Chorrillo*. Nickerson. Pamplona- Huesca, Km.1231470 ELORZ (Navarra).
- [22] Lobo. (2010). *Sembradoras Principios y Características*.
- [23] Baker, Jhon; C, *Modelos de Sembradoras y de Sembradoras de Precisión para Labranza cero – Maquinas para Trabajo en gran Escala*.
- [24] Electrodo Infra. (2010). *Manual de Electrodo para Soldar*. AnsiRab.

5. Linkography

- [25] Obraweb.(2005). *Sembaradoras de precisión industriales*. Recuperado: http://www.obraweb.com/browse_items.aspx?ctl_id=1&cat_stitle=lamigal&productlevel=1&levelone=0&cat_parent_id=6410.
- [26] Scribd.(2009). *Transmisiones*. Recuperado: http://www.scribd.com/doc/25882475/TRANS_MISION-MECANICA.
- [27] Infoagro.(2011). Recuperado: <http://www.infoagro.com/hortalizas/zanahoria.htm>.
- [27] Terradonis. Recuperado: <http://www.terradonis.com/es-sembradoras-hortícolas-semillas-pequeñas.php?lg=es>.
- [28] Facilísimo.com.(2008). *Documentales Sembradores*. Recuperado: http://bricolaje.facilísimo.com/reportajes/carpintería/muebles-de-madera/una-sembradora-paso_190377.html.



FICA, Vol. X, No. X, MES 20XX

Geovanny A. Chiriboga I., Autor

**Student of the School of Mechatronics Engineering
at the Tecnica University Northern**

Arias O., Autor



**Teacher of the School of
Mechatronics Engineering at
the Technical University
Northern**