



TECHNICAL UNIVERSITY NORTHERN

FACULTY OF ENGINEERING IN APPLIED SCIENCE

MECHATRONIC ENGINEERING

“CONSTRUCTION OF A MACHINE SAWDUST BRIQUETTES”

SCIENTIFIC ARTICLE

AUTHOR: CÉSAR SEBASTIAN ESPINOSA SILVA

DIRECTOR: ING. ZAMIR MERA

IBARRA – ECUADOR

2016

Construction of a Machine Sawdust Briquettes

Cesar Sebastián Espinosa Silva

¹ Mechatronics, FICA, Technical University Northern Av. July 17, Ibarra, Ecuador

espinosa.sebastian91@gmail.com

Summary. *This project describes the design and construction of a sawdust briquetting machine, with which you can reuse a timber waste, which pollutes our environment by briquetting. For the construction of the machine it is essential to know the characteristics of the raw materials used and the different ways to compact and bind biomass; once established these parameters proceeds to design the different parts that make up the machine, then the simulations performed before the construction of the parts. Electrical installations and the implementation of the control system and cutting is done, finally testing the correct operation of the machine which will start or make briquettes are made.*

Keywords

Briquetting, sawdust briquettes.

1. Introduction

One of the problems that has confronted our society in recent times is excessive waste generation, which cause environmental pollution by unawareness of human beings to no better manage these form waste and throw indiscriminately to environment.

The large amount of wood that is used today by wood industries such as sawmills, furniture factory or carpentry, generate large amount of sawdust, material considered as waste, which becomes a problem for both industries, workers and the environment if improperly thrown, so it is necessary to implement appropriate machinery to reuse such waste. Currently the use of forest waste has a high degree of wastage. Sawdust, wood shavings, is stored in large physical spaces, without having higher added value or achieve greater energy efficiency. [1]

Building a sawdust briquetting machine allow innovate and contribute to better management of wood waste, it will take advantage of better way this waste by briquetting sawdust.

2. Materials y Methods

2.1. Raw Material

The raw material used for briquetting is wood sawdust. Sawdust or sawdust is waste process wood sawing, such as that occurs in sawmills. The following table shows the properties that have sawdust. [2]

Parameter	units	Value
Density	$\left[\frac{kg}{m^3}\right]$	200 - 350
Specific heat	$\left[\frac{J}{kg \cdot K}\right]$	1400
Thermal conductivity	$\left[\frac{W}{m \cdot K}\right]$	0,05

Table 1. Properties of the sawdust

2.2 Compaction Technologies

Technologies analyzed for briquetting are:

PISTON BRIQUETTING. Its operation is based on the tapping of a piston by means of a flywheel on the raw material. It is a high pressure machine compaction. Briquettes densities achieved are usually between 1,000 and 1,200 kg / m³.

SCREW BRIQUETTING. The process is based on the pressure exerted on the raw material by means of a screw made of a special material, this rotates at a certain speed by advancing the material to a chamber where it is gradually reduced conically. This process can be obtained briquettes higher density than the method by impact reaching densities of about 1000-1400 kg / m³.

BRIQUETTING HYDRAULIC OR PNEUMATIC. The pressure in this type of machine is produced by several pistons to see 1,2 or 3, which are actuated by hydraulic or pneumatic systems. The density achieved is 700 to 800 kg / m³ to 900 times or 1000 kg / m³

ROLLER BRIQUETTING. These machines are provided by two rollers, on the surface thereof are a plurality of recesses where the material to be compacted is housed, being compressed by the action of the other roller. The compaction of the material is done with the help of a binder

For the selection of the best alternative compaction method corrected weighted ordinal Charles Riva [3] criteria used. After this analysis and parameters you want to get the best alternative is the briquetting screw.

2.3 Screw compactor design.

Briquetting machines consist of a type extruder screw compactor. The most important parameters to consider in the design of the screw are the length, diameter, thread angle and thread pitch. [4].

PRODUCTION SCREW. Based screw diameter D = 0.07 m channel depth h = 0.01 m and 0.036 m step. Production is indicated in volumetric flow (Q), which is composed of three types of flows. The drag flow, which is the largest of the three produced by the drag of the material. The flow pressure is that which opposes the flow of the system, ie it is the return flow. The filtration flow, is one that reduces the output due to losses of material produced in the body clearance and the screw cylinder. This flow is determined by the following equation.

$$Q = \left(\frac{\alpha * K}{K + \gamma + \beta} \right) n \quad (1)$$

Where: α = drag flow [m³], β = pressure flow [m³], γ = flow filtration [m³], K = geometric shape of the nozzle [m³], n = revolutions per minute [rpm].

Drag flow. It is determined by.

$$\alpha = \frac{\pi * m * D * h * \left(\frac{t}{m} - e \right) * \cos(\varphi^2)}{2} \quad (2)$$

Where D = diameter of the screw, h = depth of the channel, m = number of channels steak, t = pitch of the thread, e = thickness of the fillet, φ = angle of the propeller.

Flow pressure. It is determined by

$$\beta = \frac{m * h^3 * \left(\frac{t}{m} - e \right) * \sin(\varphi) * \cos(\varphi)}{12 * L} \quad (3)$$

Where L = length of the screw.

Flow losses. It is determined by.

$$\gamma = \frac{\pi^2 * D^2 * H^3 * \tan(\varphi)}{10 * e * L} \quad (4)$$

Geometric shape of the nozzle. For a conical nozzle is determined by

$$K = \frac{3 * \pi * d1^3 * d2^3}{128 * l * (d1^2 + d1 * d2 + d2^2)} \quad (5)$$

Where d1 = diameter entry of material, d2 = diameter material outlet, l = length of the nozzle.

Getting the respective production results volumetric screw is.

$$Q = 83,04 \frac{Kg}{hr}$$

2.4 Power calculation engine

This calculation is performed based on the production of the screw and the compacting pressure by the following expression.

$$P_o = P * Q \quad (6)$$

Where P = pressure of the machine, Q = volumetric flow.

According to the document published by FAO [5] states that the pressure of the briquetting machine ranges from 60 MPa up to 100 MPa.

$$P_o = 8,80 \text{ KW}$$

POTENCY CORRECTION

LOSSES ON ELECTRICAL INSTALLATIONS

It originates from the power source line receiving and delivering the end.

$$Z_e = 0,015 * P_o \tag{7}$$

LOSSES IN MOTORS AND GENERATORS

They are generated by incorrect pre on.

$$Z_m = 0,05 * P_o \tag{8}$$

The corrected engine power is:

$$P_c = 9,37 \text{ KW}$$

2.5 Potency transmission system

The band system in V was selected due to its flexibility, minimal maintenance, good elasticity, low cost of ownership, market availability; moreover they will prevent the screw being damaged if an overload arises, causing the bands slipping on the pulleys.

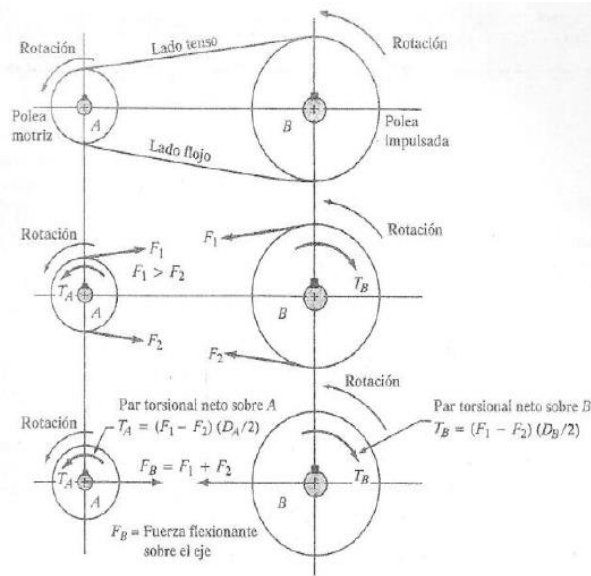

Figure 1. Potency transmission by pulleys

Figure 1 shows the forces acting on the pulleys shown. To calculate the torque in the driving pulley the following equation is used.

$$T_a = \frac{9550 * P_m}{v_m} \tag{9}$$

Where P_m = engine power v_m = engine speed.

$$T_a = 61,04 \text{ Nm}$$

To calculate the torque in the driven pulley the following equation is used.

$$T_b = (F_1 - F_2) * (\frac{D_2}{2}) \tag{10}$$

Where D_2 = diameter driven pulley, F_1 and F_2 = forces on the pulleys.

$$T_b = 485,52 \text{ Nm}$$

To calculate the bending force the following equation is used.

$$F_B = \frac{1,5 * T}{\frac{D}{2}} \tag{11}$$

Where T = torque, D = diameter.

$$F_B = 1602 \text{ N}$$

2.6 Driveshaft Design

The shaft is responsible for transmitting the power from the driven pulley to the screw compactor

The following figure shows the axis configuration.

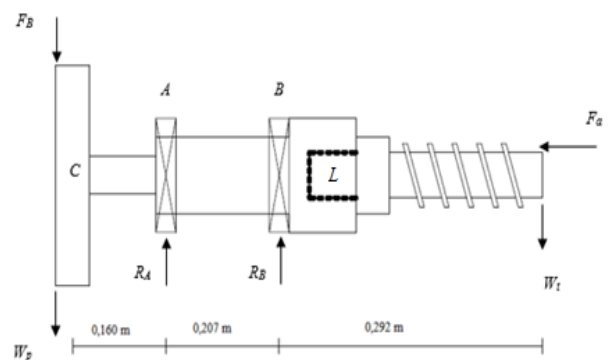

Figure 2. Setting axis.

To determine the shaft diameters is performed by applying the failure theory of Goodman, by the following equation. [6]

$$d = (\frac{16N}{\pi} \{ \frac{1}{s_e} [4(k_f M_a)^2 + 3(k_{fs} T_a)^2]^{\frac{1}{2}} + \frac{1}{s_u} [4(k_f M_m)^2 + 3(k_{fs} T_m)^2]^{\frac{1}{2}} \})^{\frac{1}{3}} \tag{12}$$

Where k_f = Factor of stress concentration fatigue for the moment, M_a = alternating time k_{fs} = factor of stress concentration by fatigue torsion, T_a = torque alternating, M_m = mean time, T_m = couple medium torque.

The following table shows the diameters obtained and selected diameters.

Position	Number of diameter	Diameter of design [m]	Diameter selected [m]
Pulley	d_1	0,0429	0.045
Bearing A	d_2	0,0532	0.065
Bearing B	d_3	0,044	0.065

Table. 2. Diameter values.

2.7 Cylinder design.

To determine the outer diameter of the cylinder necessary to calculate the thickness that will have this. To calculate the thickness, the analysis as a thick-walled cylinder is done because inside must withstand high pressure.

$$t = \frac{D}{2} \left(\sqrt{\frac{2P}{\sigma_{di} - 2P}} - 1 \right) \tag{13}$$

Where D = internal diameter, P = pressure = design effort

$$t = 0.0135 \text{ m}$$

Once the thickness obtained is verified that the cylinder is a thick-walled cylinder with the following relation.

$$\frac{D}{t} < 10$$

$$5,38 < 10$$

2.8 Increase in the internal energy of the raw materials

It is necessary to determine the amount of energy needed to raise the raw material to the desired temperature.

$$E_{ag} = \frac{dm}{dt} c p_m (T_{sa} - T_a) \tag{14}$$

Where E_g = amount of heat added, d_m / d_t = mass flow m cp = specific heat of the raw material, T_{sa} = temperature of the raw material to the output, T_a = ambient temperature. [7]

$$E_{ag} = 4,04 \text{ kW}$$

The theoretical amount to raise the temperature is 4.04 kW, for which an output of 4.5kW distributed in three resistors is selected.

2.9 Analysis by finite elements

Once finished with the design of the parts of the machine simulations performed them.

SCREW. To simulate loads should be placed to the screw. During briquetting the screw is subjected to both torsional and axial loads for the work done.

The stress analysis is performed at the critical point of the screw (in the stress concentration by changing section). The following show the results obtained include

Name	Kind	M in.	M ax.	Average
Voltages	VON: Mises von Tension	51.64 (MPa)	284.07 (MPa)	166.57 (MPa)

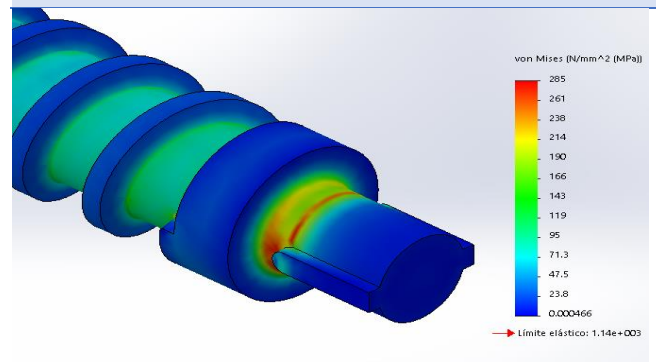

Figure. 3. Efforts screw.

Name	Kind	M in.	M ax.	Average
Security factor	Automattic	2.43	13.36	5.48

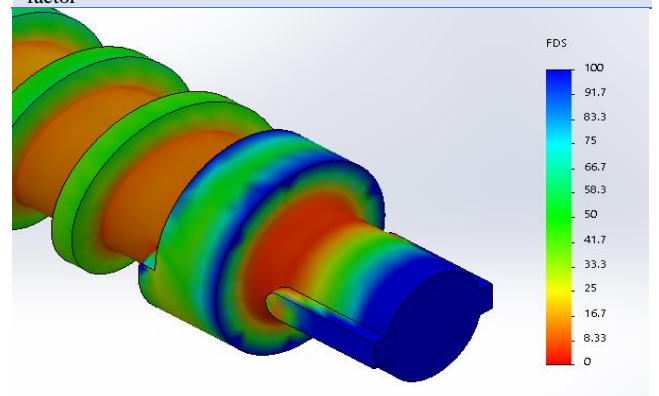

Figure. 4. Safety factor.

By this analysis an average of 166.57 MPa and effort average safety factor of 5.48, which is an acceptable factor was obtained.

CYLINDER. For the simulation of the cylinder, it is to be performed in two parts: a static analysis and thermal analysis. Thermal analysis was performed in a state transitional rules to determine the temperature increase according to the time.

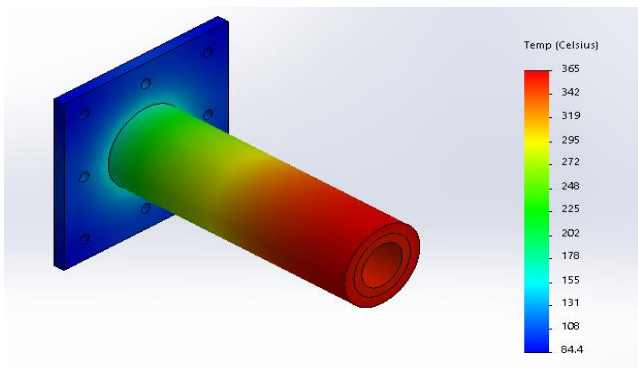

Figure 5. Simulation Cylinder temperature t = 930s

This analysis was obtained after 930 seconds, the temperature reaches the desired value.

For static analysis cylinder pressure generated during the briquetting process it is applied. Include the following show the results obtained.

Name	Kind	M in.	M ax.
Tensions	VON: Tension of von Mises	0.00785137 (MPa) Nodo: 3885	227.931 (MPa) Nodo: 13321

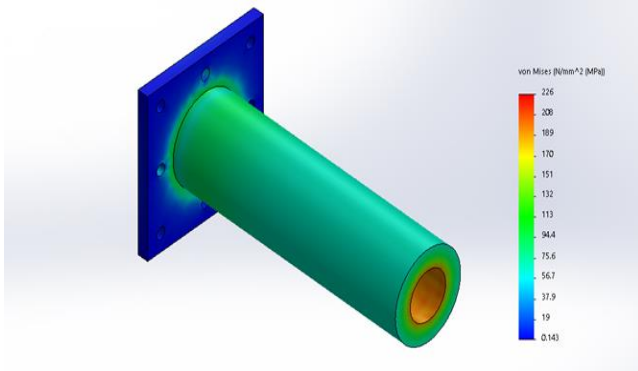

Figure 6. Efforts Cylinder

Name	Kind	M in.	M ax.
Security factor	Automattic	2.14977 Nodo: 13321	62409.5 Nodo: 3885

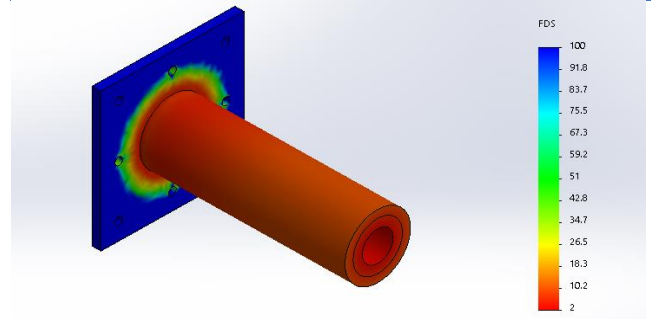

Figure 7. Safety factor cylinder

By this analysis a maximum stress of 227.92 MPa and average safety factor of 2.15, which is an acceptable factor was obtained.

3. Results

The results obtained after performing the test operation of the machine were as follows.

HEATING TEST.

The test was performed by taking the time it takes to heat the cylinder to reach the temperature to start the process. The following graph shows the results obtained

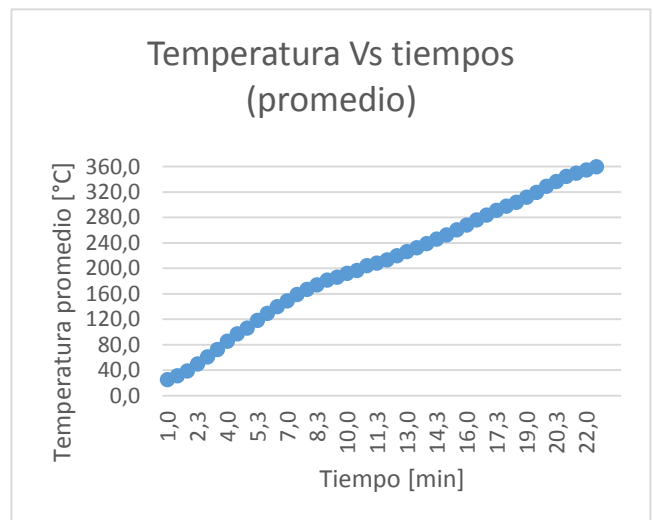

Figure 8. Testing machine heating

As shown in the previous figure the time it takes the machine to reach the desired temperature is approximately 21 minutes.

TEST OF PRODUCING BRIQUETTES.

In this test the final density of the briquette at various temperatures is determined. Tests for obtaining the briquettes are made taking into account parameters such as heating temperature and density of the briquette. The following tables show the results obtained.

Temperature [°C]	Density average [kg / m ³]	Observations
240		It could not be determined Briquette is not formed.
260		It could not be determined Briquette is not formed.
280	1189.848	Briquette is obtained with difficulty comes with a very cold agile body.
300	1182.012	Briquette is obtained with difficulty comes with fragile body.
320	1179.999	Briquette is obtained with difficulty comes with normal body.
330	1175.910	Briquette is obtained out without difficulty with a normal body.
340	1172.770	Briquette is obtained out without difficulty with a normal body.
350	1166.153	Briquette is obtained out without difficulty with a fragile body.

Table 3. Obtaining test briquettes.

The temperature suitable for briquetting is between 330 and 340 oC with a density of 1175.910, 1172.770 Kg / m³ respectively. These values may vary, it depends on the wood used to make the briquette type.

PRODUCTION TEST MACHINE

The performance of this test was to determine the object briquette production machine. This test is performed by measuring the mass of the briquettes after a certain time (1 hour). The following table shows the results obtained.

Number of samples	Time [hr]	Briquette mass [kg]
1	1	82,1
2	1	81.5
3	1	81,8
4	1	81.6
Average		81,75

Table 4. Machine production.

The machine has an average production of 81.75 kg / hr; fulfilling the design range is 80 kg / hr.

CUT TEST.

The tests were performed at court system were to verify the percentage of error that the final size of the briquette respect to the desired distance: 15 cm. For this several briquettes they were taken and went on to perform the measurement of length. The following table shows the results obtained.

Number of sample	Desired length [cm]	Measured length [cm]	Error rate [%]
1	15	15,3	2
2	15	15,5	3.33
3	15	16,5	10
4	15	16,5	10
5	15	16	6.67
6	15	14,5	3.33
7	15	15,8	5.33
8	15	16,5	10
9	15	16	6.67
10	15	14,8	1.33

Table 5. Briquette test cut.

The average percentage error briquette cutting system is 3.2%, with a low and acceptable percentage.

Conclusions

With the completion of this work it was possible to design and build a sawdust briquetting machine extrusion for

the production of briquettes using as raw material waste wood sawdust.

The extruder screw was designed so that the machine has an output of 82 kg / h. Because the loads that will be exposed screw, the material used for its construction is a AISI 4140 steel which exhibits good strength properties, wear and ability to withstand high temperatures.

The cylinder was designed to withstand the pressure generated 80 MPa when compacted sawdust and form briquettes. The material used for its construction is steel 1518 (perforated rod), which facilitated machining.

With the briquetting process it was possible to increase the density of the raw material of 215 kg / m³ to 1162.63 kg / m³ by producing sawdust briquettes.

By briquetting it could make better use of the waste timber industries, wood sawdust, through recycling, in addition to obtaining a product with better features.

Bibliographic references

- [1] Soto, G., & Nuñez, M. (s.f.). SciElo. Obtenido de http://www.scielo.cl/scielo.php?pid=S0718-221X2008000200005&script=sci_arttext
- [2] Ahn, H., Sauer, T., Richard, T., & Glanville, T. D. (2009). Determination of thermal properties of composting
- [3] Riva, C. (2002). *Diseño concurrente*.
- [4] Savgorodny, V. K. (s.f.). *Transformación de plasticos*. Barcelona: Gustavo Gili.
- [5] Departamento de Montes. (s.f.). *Depositos de documentos de la FAO*. Obtenido de Conservación de energía en las industrias mecánicas forestales : <http://www.fao.org/docrep/t0269s/t0269S10.htm>
- [6] Budynas, R. G., & Nisbett, J. K. (2008). *Diseño en ingeniería mecánica de Shigley*. McGraw-Hill.
- [7] Cengel, Y. A. (2009). *Transferencia de calor*. Mexico: McGraw-Hill.

Author

Author-Cesar Espinosa Sebastián Silva. He completed his primary education in the private school “Madre Tereza Bacq”. His secondary studies were conducted at the Salesian Sanchez y Cifuentes high school in the specialty of Physical Mathematical obtaining the merit of second escort of the National flag. Currently he is a graduated of the “Universidad Técnica del Norte” in Mechatronics Engineering. Areas of interest: mechanical design, robotics, electronics and process automation.