

## “DESIGN OF BLANCHER MACHINE FOR PROCESSING OF CHICKENS IN THE ARTESANAL INDUSTRY”

Carlos Villarreal, Mauricio Sánchez

**Abstract.** - This paper aims to design and construction system that allows scald chickens in a similar manner to that being processed, the quality of the chicken with the help of a control water temperature and time will be improved scalding.

It's was performed a study of the different forms and methods of blanching which characteristics of each were made to attach to a new design that will improve the quality and conserve resources such as water and fuel, will allow lower production costs chicken.

To determine the ranges of water temperature and the blanching time data acquisition was performed on a slaughtering resulting, for the process of chickens by hand a temperature range of 65 ° C to 70 ° C is needed and for the process 52 ° C to 56 ° C machine, this in a time of 60 s and 90 s respectively.

### 1. Introduction

This paper is the need to improve the quality and hygiene in the process of slaughtering chickens through a scalded appropriate. Blanching is one of the most essential steps, this must be controlled variables such as temperature and residence time of the chicken in the tub and directly affecting the quality of the plucking chickens, if this is done in a way inadequate leads to wasted time and money.

Currently the blanching process is performed manually and empirically, this parameter controls no as the water temperature and time of blanching. During this process the chickens enter be scalded at a temperature low or high water, just as the blanching

time, thereby directly affect the quality of processed chicken.

### 2. The Poultry production in Ecuador

The poultry industry in Ecuador is established as one of the most important activities in the food context, because of its great contribution along the entire food chain from production of raw materials, such as, the morochillo and soybeans, for preparing balanced until they are finally poultry feed source to produce eggs and meat foods.

In Figure 1, it can be seen that the consumption of chicken meat has had a remarkable growth in the country, in the ninetieth year was estimated at 7 kg / person / year in 2012 to 32 kg / person / year, being due to the high demand for this product and reasonable prices in relation to substitutes. (Jarrin, 2014)

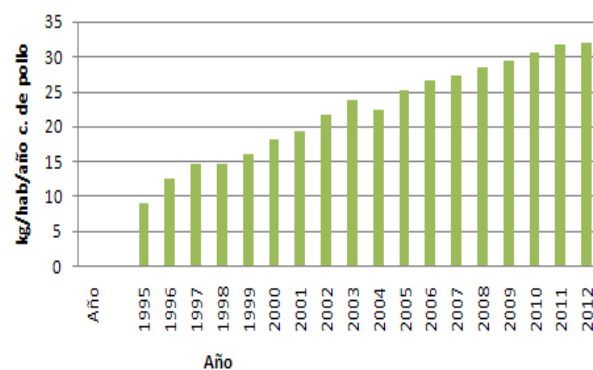

Figure 1.- Chicken consumption per capita of Ecuador in years 1995-2012.

Source: (Conave, 2014)

#### 2.1. The process of slaughtering

In Figure 2 the process of culling, which begins with the reception of birds that go to slaughter

indicated; are removed from the cages to place on the transport system, then proceed to slaughter them, leaving them to bleed, then they enter the area scald, pluck, and removal of visors to be stored and transported to market

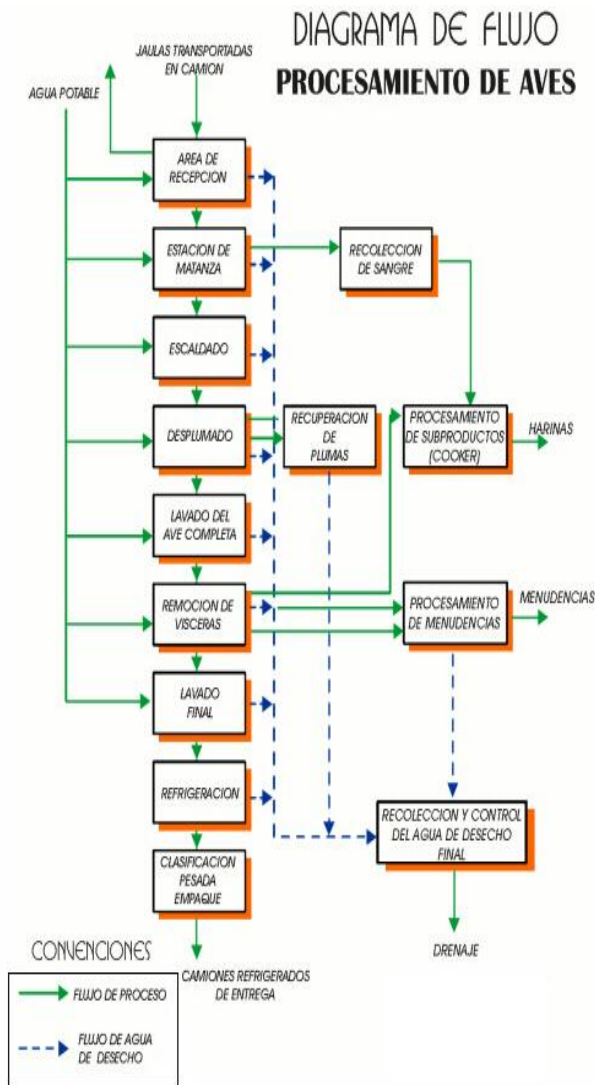

Figure 2. - Flowchart of the process of slaughter of chickens.

Source: (Tecnologías Limpias, 2015).

## 2.2. Scald chickens.

The blanching is done chickens to loosen feathers inserting in the follicles, and their elimination is not possible to implement dry, facilitating subsequent plucking operation.

Normally blanching is done by immersion in hot water, and three types are distinguished: blanching high, medium and low blanching depending on the parameters of time and temperature. In the handicraft industry the most used are high for plucking process scalded hand and scalded low for the process of plucking machine.

During the stay of chickens in the tub of scalding water should be shaken to penetrate between the feathers and skin reach, fulfilling its function of opening the follicles. The main agitation systems are pumping, turbines and air injection.

The water temperature is controlled depending on the method with blanching, manually or automatically through the cold water inlet and ignition of the thermal energy source.

### 2.2.1. Blanching methods chickens

Methods for scalding poultry of which advantages and disadvantages of each for the design of a blancher be analyzed are described chickens

#### 2.2.1.1. Traditional blanching

Advantage:

- Low acquisition cost.
- Low production.



A: Olla de escaldado  
B: Agitador  
C: Fuente de energía calorífica  
D: Recipiente

Figure 3 . - Pot for traditional blanching of chickens.

Disadvantage:

- There is no time control, temperature blanching.
- High physical exertion.

- Risk burns.
- High water expenditure.
- High degree of contamination.
- Chicken sleazy.

#### 2.2.1.2. Tub blanching with blades.

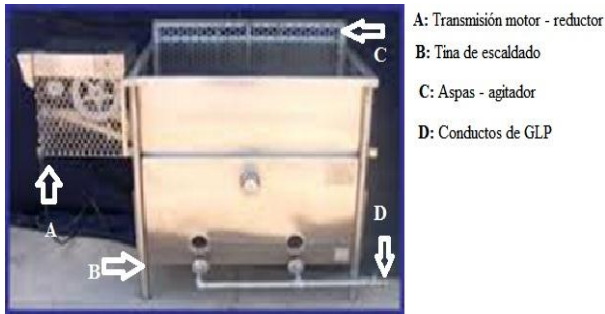

Figure 4.- Tub blanching with blades.  
 Source: (MAC, 2010)

#### Advantage:

- Reduce physical effort the worker.
- Moderate acquisition cost.
- Saving water.
- Moderate production

#### Disadvantage:

- Battered chicken.
- High degree of contamination.
- On scalded.
- High degree of contamination.

#### 2.2.1.3. Scalding chickens for production line immersion.



Figure 5.- Scalding chickens for production line immersion.  
 Source: (Poultry Dressing plant Scalding or Chicken Scalding, 2013)

#### Advantage:

- Reduce physical effort the worker.
- Saving water.
- Saving fuel (LPG or diesel).
- High production and good quality.
- Moderate degree of contamination.

#### Disadvantage:

- High acquisition cost.

#### 2.2.1.4. Blanching steam chickens "Hotbox".

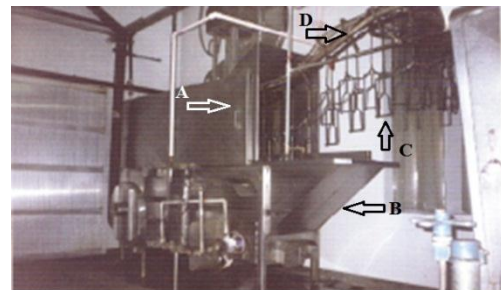

Figure 6.- Chickens blancher with steam.  
 Source: (Valenti, 2013)

#### Advantage:

- Low physical effort of the workers.
- Saving water.
- Saving fuel (LPG or diesel).
- High production and good quality.
- Low degree of contamination.

#### Disadvantage:

- High acquisition.

#### 2.2.1.5. Problems scald chickens.

When the water temperature exceeds 70 ° C and blanching time is prolonged cooking of the epidermis occurs causing skin breakdown at the stage of plucking, this is referred to blanching, as shown in Figure 7 to. With the temperature below 50 ° C, discoloration is generated on chicken skin (spots, uneven color) due to lack of heat transfer to the follicles plucking is inefficient, increasing the

processing time Chicken; this phenomenon is observed in Figure 7 b

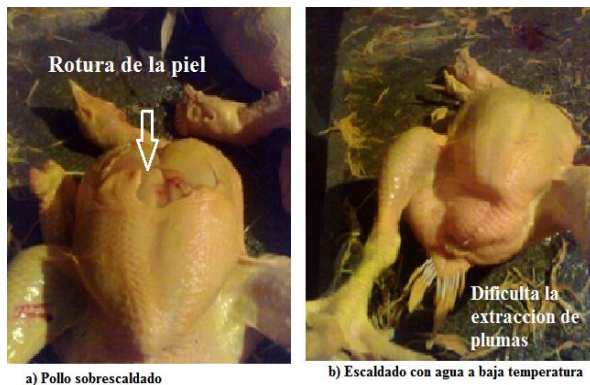

Figure 7 . - Problems having no control blanching time and blanching temperature.

### 2.2.1.6. Parameters for optimal blanching

The parameters for a scalded optimal, water temperature and time of blanching was carried out data collection with the method of traditional craft scalded to set these parameters, reading of two batches of chickens were processed, resulting in an average of 67 ° C water temperature, with a time of 73 s for high blanching and 54 ° C water temperature with a time of 90 s for a scalded low. These parameters will be considered later for designing the blancher.

### 2.2.1.7. Selecting the right alternative for scalding chickens

To select the appropriate alternative, take into account the advantages and disadvantages of each of the above methods, the following criteria are also taken into account.

- Physical exertion staff slaughtering plant.
- Water consumption.
- Fuel consumption.
- Pollution degree.
- Cost Manufacturing.

Table1: Selection of the alternative design for the blancher.

PARAMETER	ALTERNATIVE			
	T R A	TI N A	PROD UCCIÓ N EN	VAPOR
PHYSICAL EFFORT	10	9	5	5
WATER USAGE	10	8	5	2
FUEL CONSUMPTION	9	8	6	8
COSTE	1	3	5	10
POLLUTION DEGREE	10	8	5	1
<b>TOTAL</b>	<b>40</b>	<b>36</b>	<b>26</b>	<b>26</b>

With the results of Table 1 shows two alternative design, the production method online by immersion and steam blanching of being despised last for the cost parameter is not accessible to the handicraft industry.

With this blanching is determined that the production line is the best alternative for the design of the machine.

## 3. Design line by immersion chickens blanching.

Figure 8 shows the systems and elements that make up the line scalded chicken by immersion.

Figure 9 a sketch of the machine with their respective systems and elements that detailed forms.

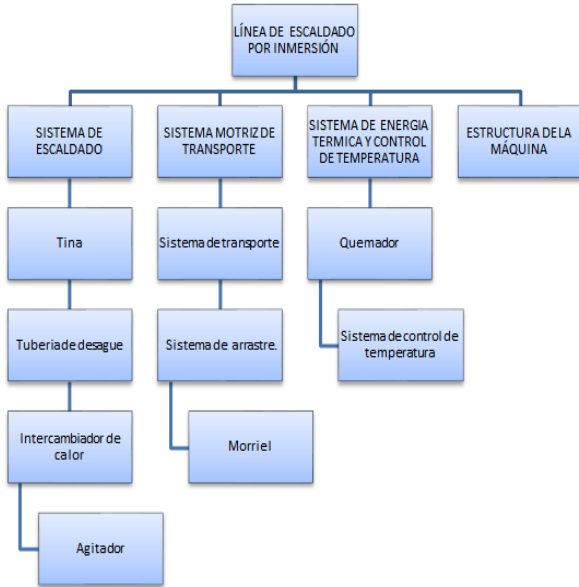

Figure8: Systems and elements of the by immersion scald chickens

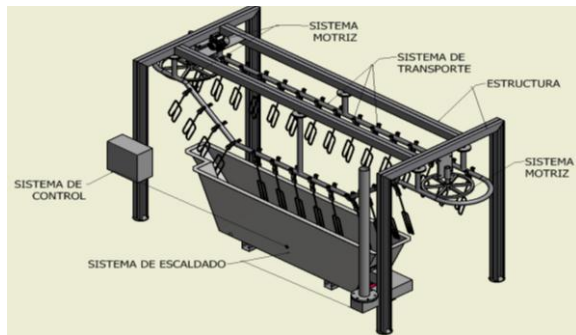

Figure9: Scalding chicken by immersion and systems that comprise systems

The systems comprising the immersion scald chickens are:

- System scalded.
- Motor and transport system.
- System thermal energy and temperature control.
- Machine structure

### 3.1. Mechanical design and system sizing blanching

In Figure 10 the elements forming the detailed blanching system:

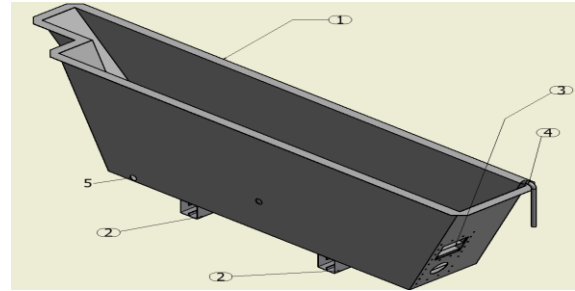

Figure10: Elements of the system scalded

1. Tina blanching.
2. Basis of the tub
3. Heat exchanger.
4. Stirrer.
5. hole for drainage

#### 3.1.1. Tub design blanching

By measuring several different sized chickens a sample of which the maximum values must be taken to ensure that the height and width of the tub are adequate and that chickens are kept fully submerged in water for processing it was obtained.

A space as tolerance of  $0.14 \text{ m Eq} = \text{plus}$  for accommodating the heat exchanger, likewise in the height of the tub is added is added  $0.12 \text{ m}$  to ensure that chickens are immersed in their entirety for blanching process

Then:  
 $A_t = 0,4 \text{ m.}$   
 $H_t = 0,74 \text{ m.}$

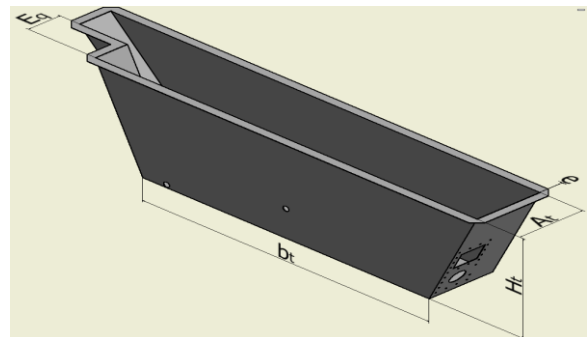

Figure 11: Nomenclature for Tub design



To determine the length of the base of the tub of the tub is needed the value of the speed and time of blanching

V: speed blanching.

$b_t$ : base of the tub.

t: time blanching.

$$V = \frac{b_t}{t}$$

$$b_t = 1,8 \text{ m}$$

It is established that the scalding tub will have a length of 1.8 m

To determine material thickness tub has the following is detailed in Figure 12:

$e_t$ = thickness scald tub.

P= hydrostatic pressure exerted by water.

$H_{\text{agua}}$ = high water level.

For this the force exerted by the water on the tub of scalding is determined.

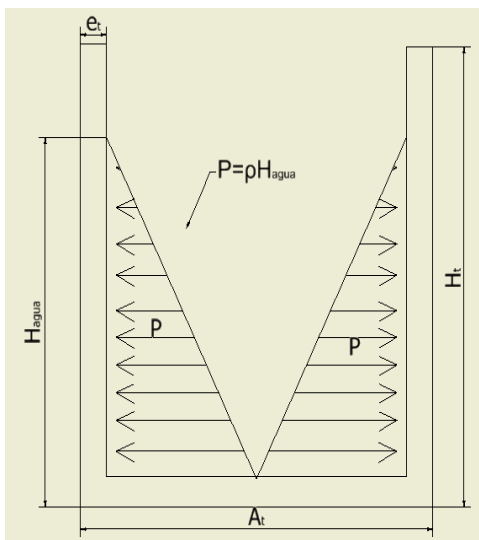

Figure12: Nomenclature for designing the thickness of the material of the tub blanching.

To calculate the volume of water in the tub is taken into account, the tub will not fill to the limit to avoid spillage of water, and this house the heat exchanger

and chickens are the process inside the tub. Figure 13 shows the detail for calculating the volume of water.

Where:

$e_{\text{libre}}$ : free space to avoid spilling water. [0,1 m].

$A_i$ = Width of the heat exchanger chamber. [0,14 m].

$h_i$  = Width of the heat exchanger chamber. [0,15 m].

Frontal length Chicken = [0,26 m].

Chicken body length = [0.48 m], discounting the dimensions of the length of the legs and head.

For calculating the volume average chicken [0.10 m] is taken, the thickness of the chicken.

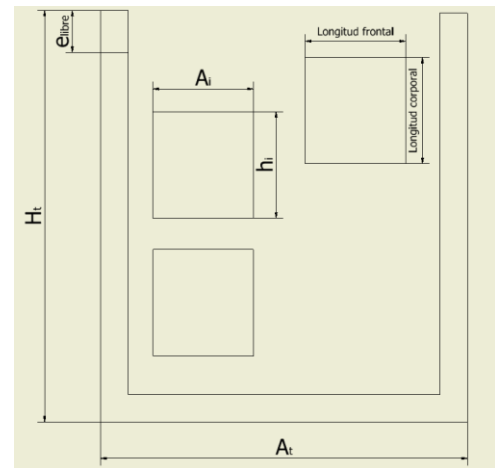

Figure 13.- Dimensioning to determine the volume of water in the tub.

$$V_{\text{tina}} = V_{\text{total}} - V_{e \text{ libre}} - V_{\text{intercambiador}} -$$

$$V_{\text{pollos en proceso}}$$

$$V_{\text{total}} = A_t * H_t * b_t$$

$$V_{\text{total}} = 0,5328 \text{ m}^3$$

$$V_{e \text{ libre}} = e_{\text{libre}} * A_t * b_t$$

$$V_{e \text{ libre}} = 0,072 \text{ m}^3.$$

$$V_{\text{intercambiador}} = A_t * h_i * L_i$$

As are two cameras:

$$V_{\text{intercambiador}} = 0,0378 \text{ m}^3.$$

Seven Are chickens process then

$$V_{pollos\ en\ proceso} = 0,0874\ m^3$$

$$V_{tina} = 0,2978\ m^3$$

We then determine the force exerted by the volume of water in the wall.

$$F_{agua} = \rho * V_{tina}$$

$$F_{agua} = 2.978\ N$$

With this we have the free body diagram of Figure 14

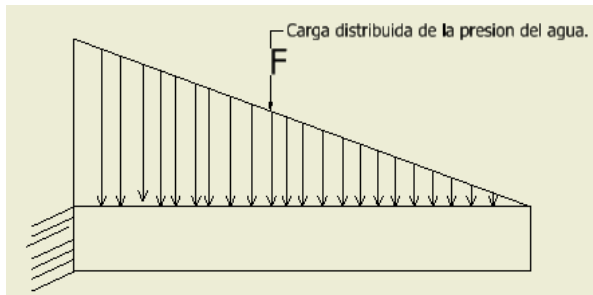

Figure 14: Distributed load on the wall of the tub of scalding.

Figure 15: Determination of the reaction and the force applied.

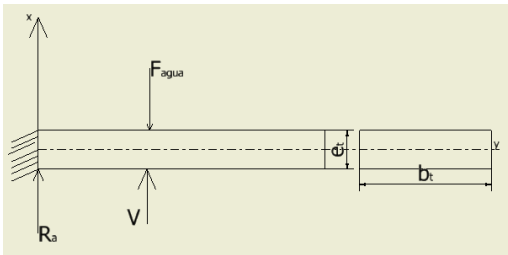

Figure 15.- Free body diagram with shear V.

The reaction is determined Ra.

$$\Sigma F_x = 0$$

$$R_a = -F_{agua}$$

The point load exerted water is  $\frac{1}{3}H_t$ , then the force is:

$$F_{water} = \frac{1}{3} * \left( \frac{H_t * F}{2} \right)$$

$$F_{water} = 367,2866\ N$$

In Figure 16, the free-body diagram shown to determine the shear.

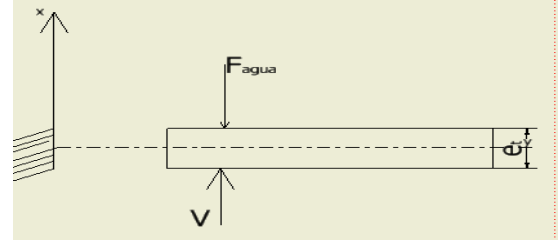

Figure 16.- Free body diagram to determine the shear.

$$V - F_{agua} = 0$$

$$V = F_{agua}$$

To determine the thickness of the tub is the following equation:

$$\tau = \frac{V * M_e}{I * e_t}$$

Where:

$\tau$  = Maximum shear stress

V= shear force

$M_e$  = Time with respect to the neutral line

$A_{F\ agua}$  = Area where the force of water applied.

I= inertia.

$$M_e = A_{F\ agua} * \bar{y}$$

$$M_e = \left( \frac{e_t}{2} * b_t * \bar{y} \right)$$

$$M_e = 0,225\ m * e_t^2$$

$$I = \frac{1}{12} * (b_t * e_t^3)$$

$$I = 0,15\ m * e_t^3$$

Substituting in the equation of shear has:

$$\tau = \frac{550,93\ N}{e_t^2}$$

Where:

$$\tau = \frac{S_{y\ acero\ 304}}{FS}$$

For this design an FS 3 and the value given

$$S_{y,acero\ 304} = 600 \frac{N}{mm^2}$$

$$\frac{S_{y,acero\ 304}}{FS} = \frac{550,93\ N}{e_t^2}$$

$$e_t = 1,66\ mm$$

The thickness of the tub blanching is 2 mm, because this is available in the market.

### 3.1.2. Dimensioning the drain hole of the tub

The tub should have a hole for discharging water after each day's work location will be at the bottom of the tub as shown in Figure 17 for this equation is used Torricelli.

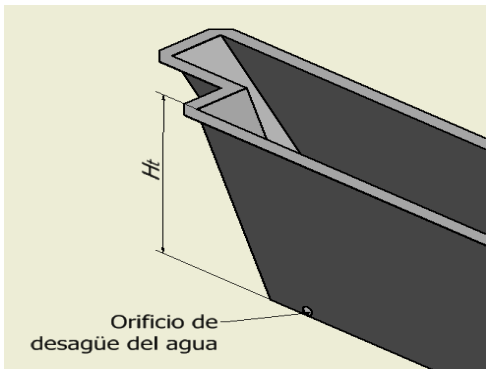

Figure 17.- Drain hole for water discharge.

$$V_{s\ agua} = \sqrt{2 * g * H_t}$$

Where:

$V_{s\ agua}$  = Output speed water.

$g$  = gravity  $9,82 \frac{m}{s}$ .

$H_t$  = height of the tub 0,74 m.

$$V_{s\ agua} = 3,81 \frac{m}{s}$$

To find the right diameter of the drainpipe relate the rate of flow equations and emptying time; this time is estimated at 100 s.

$$Q = \frac{V_{tina}}{t_{des}}$$

$$Q = V_{s\ agua} * A_{tubo}$$

$$\frac{V_{tina}}{t_{des}} = V_{s\ agua} * \frac{\pi * d^2}{4}$$

$$d = \sqrt{\frac{4 * V_{tina}}{\pi * t_{des} * V_{s\ agua}}}$$

$$d = 0,032\ m$$

The diameter calculated for the discharge of water is 0.032 m

### 3.1.3. Dimensioning heat exchanger

Its design is coupled to the geometry of the tub

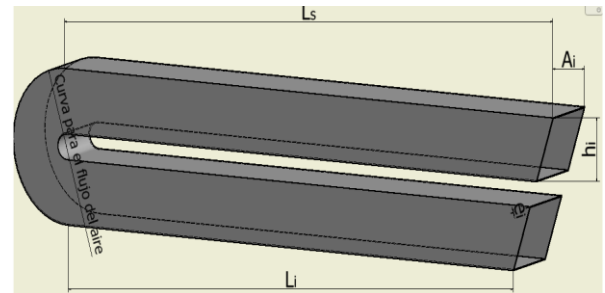

Figure 18.- Nomenclature for the design of heat exchanger

Has two compartments, one for entry of hot air injected diesel burner and the other for the exit of the combustion gases into the environment, the space between compartments will be 0.06 m, at the junction of the two cameras must have a curvature to allow the free flow of gases for transmitting heat to the bath water blanching.

Where:

$h_i$  = height exchanger

$A_i$  = width of the heat exchanger

$$h_i = 0,15\ m$$

To determine  $A_i$ , it takes into account that the largest possible contact area needed for heat transfer, width 0.26 m chicken was determined.

$$A_i = 0,14\ m$$



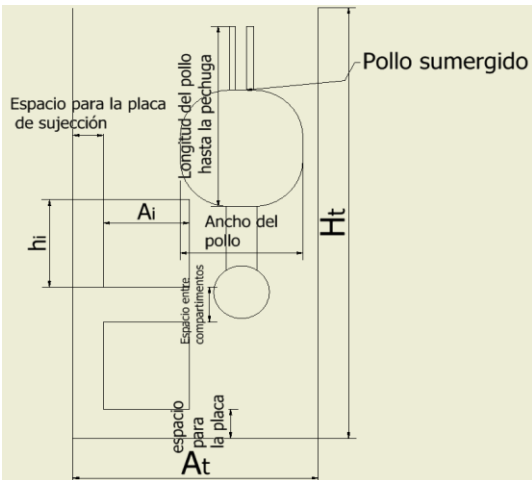

Figure 19.- Dimensioning of the heat exchanger compartments.

**3.1.4. Dimensioning Agitator**

To determine the compressor needs to know what the cost of air, which determined the volume of air in the tube agitator. Figure 20

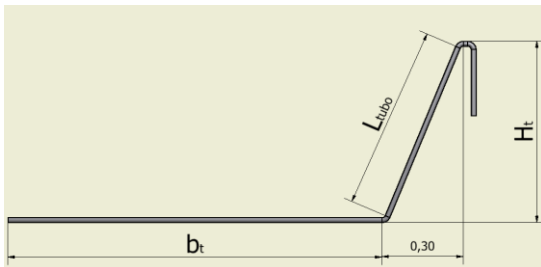

Figure 20.- Volume calculation to determine spending compressor air.

$$L_{tubo} = 0,80 \text{ m}$$

The total length will be:

$$L_{total} = L_{tubo} + b_t$$

$$L_{total} = 2,6 \text{ m}$$

The volume will:

$$V_{agitador} = 3,29 \times 10^{-4} m^3$$

This volume of air is necessary at every moment of time, for selecting the compressor this value is multiplied by 60 s, to keep spending  $\frac{m^3}{\text{minuto}}$

$$coste = 0,019 \frac{m^3}{\text{minute}} = 0,67 \text{ CFM}$$

With this it is determined the closest compressor is 2.8 CFM, commercially available.

**3.2. Design and dimensioning of transport system**

This system will be responsible for transporting chickens through the Monorail for processing consists of the following elements: sheaves and attachments that are dragged by a chain around the monorail. In Figure 21 a sketch of the system is shown.

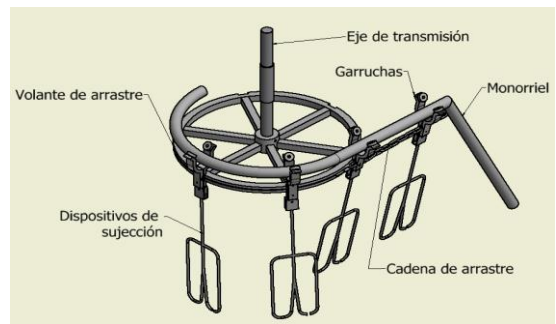

Figure 21.- Sketch transport system

**3.2.1. Sheaves and loading devices**

These are made based on some existing facilitated enterprise dedicated to the slaughter of chickens Faenavi. Figure 22 y Figure 23

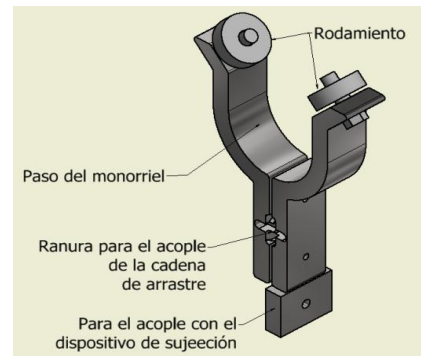

Figure 22.- Garruchas para el transporte de los pollos  
Source: Faenavi.

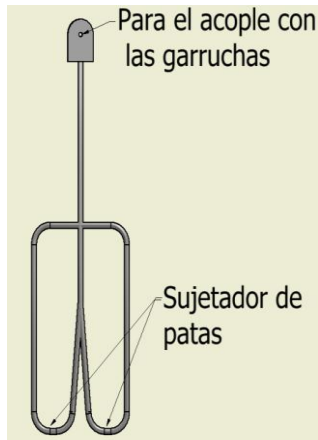

Figure 23.- Clamping device for transporting chickens  
Source: (INDUMETAVI, 2015)

### 3.2.2. Chain

The drive chain is determined according to the geometry of the pulleys; Figure 24 shows how the sheaves embrace chain for dragging.

- The material of the chain should be of a material other than pollution, such as galvanized steel will be adequate.

With the above requirement string is selected Catalog (Amenabar, 2002).

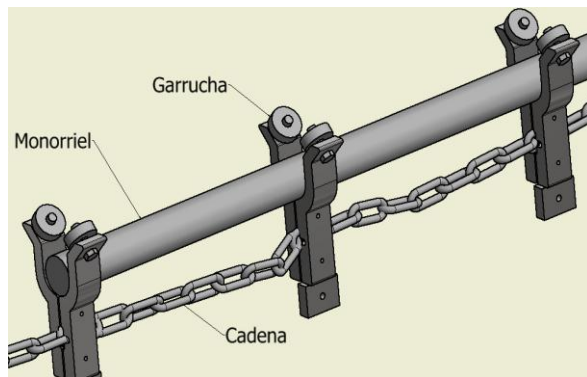

Figure 24.- Attach chain with sheaves for driving

The breaking load of the chain is 2,300 kg, compared with the,  $F_{arrstre} = 346,9 \text{ N}$ , therefore it fits perfectly to the transport system.

### 3.2.3. Monorriel.

The Monorriel will guide where chickens are transported for blanching process, it is estimated that 30 chickens simultaneously transport the estimated mass of all elements is:

The total mass is: 268,75 kg.

Then the weight of each element is:

$$P_{elemntos} = \frac{m * g}{30}$$

$$P_{elemntos} = 87,98 \text{ N}$$

This weight is evenly distributed throughout the Monorriel, the geometry that will have the monorriel for transporting chickens; inclinations will be for the entry and exit of chicken's tub of scalding, the curvature of the Monorriel to close the circuit shall not exceed 0.60 m, due to the space available for the installation of warehouse equipment. Dimensions Monorriel will be based on the dimensions of the tub of scalding, to ensure that chickens have a good scalded.

The Monorriel will be designed with the help of software because it is a statically indeterminate structure. Figure 25 shows how the monorail will be charged.

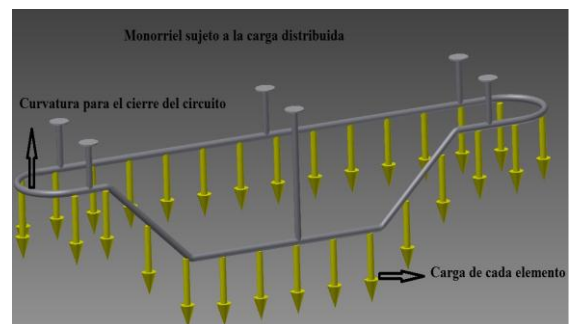

Figure 25.- Distributed load on monorriel.

The calculation is performed by the voltage Von Mises method, having a maximum stress of 18.77 MPa. Figure 26

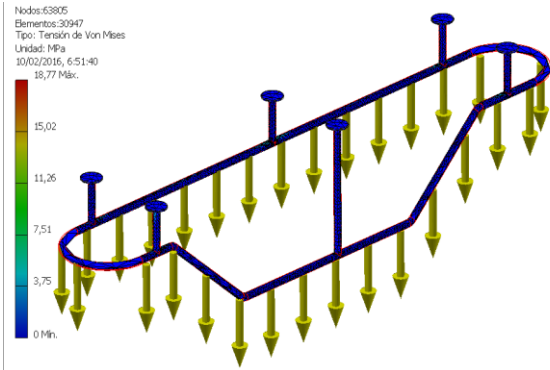

Figure 26.- Von Mises stress for monorriel.

According to the results of the software it is concluded that use a tube Galvanized  $1\frac{1}{2}$  in for the manufacture of monorriel.

### 3.2.4. Driveshaft Design flywheel drag

The shaft will be responsible for transmitting the engine torque delivered to the drive system for its design must include the following information:

$$T = 104,07 \text{ N}\cdot\text{m}$$

$$F_{\text{arrastre}} = 346,9 \text{ N}$$

AISI 1345 steel is used with the following mechanical properties.

$$\text{Maximum resistance } S_u = 13,40 \text{ MPa.}$$

$$\text{Creep resistance } S_y = 12,54 \text{ MPa.}$$

Figure 27 shows a sketch of shaft design is shown.

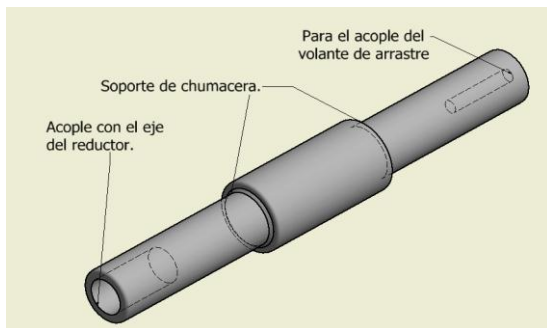

Figure 27.- Driveshaft wheel drive

The free body diagram of the steering wheel hub drive. Figure 28

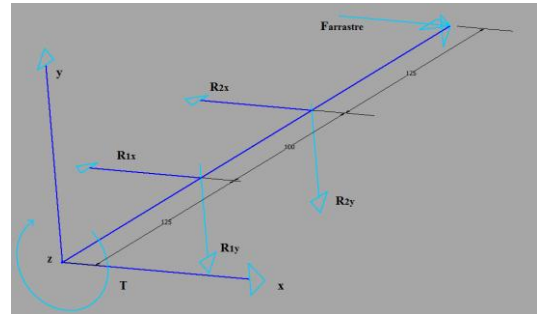

Figure 28.- Free body diagram of the steering wheel hub drag.

Free body diagram of Figure 36 forces is discussed in planes X-Z y X-Y, to effects.

To determine the reactions at the points the sum of forces and moments is performed.

Plane X-

Calculation of the resulting time ( $M_t$ ) at each point of axis: From equation

$$M_t = \sqrt{M_{x-y}^2 + M_{x-z}^2}$$

$$M_{t1} = 147,177 \text{ N} \cdot \text{m}$$

$$M_{t2} = 147,177 \text{ N} \cdot \text{m}$$

$$M_{t3} = 43,36 \text{ N} \cdot \text{m}$$

$$M_{t4} = 0 \text{ N} \cdot \text{m}$$

Calculator of shaft diameter for each point, based on the equation, that is compatible with the ANSI standard B106.1M -1985.

$$\phi_{\text{eje arrastre}} = \left[ \left[ 10,19 \text{ N} \left[ \frac{k_f \cdot M_t}{S_n} \right]^2 + 0,694 \left[ \frac{T}{S_y} \right]^2 \right]^{\frac{1}{2}} \right]^{\frac{1}{3}}$$

Where:

N: Security factor.

$k_f$ : Concentrator coefficient efforts to change section.

$M_t$ : Total time at each point.

$S_n$ : Calculation of the wing fatigue resistance.

$$S_n = C_b * C_s * C_r * C_o * S_u$$

$C_b$ : Temperature correction factor. It is 1 for room temperature.

$C_s$ : Surface correction factor depends on the shaft as will be manufactured 1, 1.

$C_r$ : Operational reliability factor 0, 90.

$C_o$ : Correction factor residual stresses. 1 For materials with thermal treatments.

$$S_n = 12,06 \text{ MPa}$$

Calculation of diameters for each section with the equation of the ASME

Calculation shaft for section 1:

$$M_{t1} = 147,177 \text{ N} * \text{m}$$

$$T = 104,07 \text{ N} * \text{m}$$

$K_f = 1,5$  rounded edges.

$K_f = 1,3$  prisoner.

$$\phi_1 = 0,047 \text{ m}$$

Calculation shaft for section 2:

$$M_{t2} = 147,177 \text{ N} * \text{m}$$

$$T = 104,07 \text{ N} * \text{m}$$

$K_f = 1,5$  rounded edges.

$K_t = 1,7$  section change.

$$\phi_1 = 0,061 \text{ m}$$

Calculation shaft for section 3:

$$M_{t3} = 43,36 \text{ N} * \text{m}$$

$$T = 104,07 \text{ N} * \text{m}$$

$K_f = 1,5$  rounded edges.

$K_t = 1,7$  section change.

$$\phi_1 = 0,044 \text{ m}$$

Calculation shaft for section 4:

$$M_{t4} = 0 \text{ N} * \text{m}$$

No torque and bending moment, therefore at this point it depends on the internal diameter of the bearing that supports an axial load equal to the resultant of the reactions in the planes X-Z y X-Y.

$$F_{t\text{ en } 4} = \sqrt{1047,7^2 + 1047,7^2}$$

$$F_{t\text{ en } 4} = 1481,6 \text{ N}$$

Therefore the axis having the following dimensions:

The smaller diameter of  $\phi_1 = 0,047 \text{ m}$ , It normalizing the diameters of the axes is 50.8 mm and the largest diameter shaft  $\phi_1 = 0,061 \text{ m}$  63.5 mm normalizing be.

In section 1 a hole for the shaft coupling the gear unit will, we proceed to the calculation of the maximum internal diameter with the following equation:

$$\tau_{max} = \frac{T * c}{J}$$

Where:

$\tau_{max}$  = maximum effort 12,54 MPa

$c$  = outer radius of the shaft  $r_e$

$r_i$  = inner radius

$J$  = polar moment of inertia for hollow shafts

$$J = \frac{\pi * (r_e^4 - r_i^4)}{2}$$

Punting  $r_i$ :

$$r_i = \sqrt[4]{r_e^4 - \frac{2Tr_e}{\pi * \tau_{max}}}$$

Calculating  $r_i = 0,023 \text{ m}$

Then the diameter reducer for coupling is 0,0254 m.

**3.2.5. Design and dimensioning of the drive system**

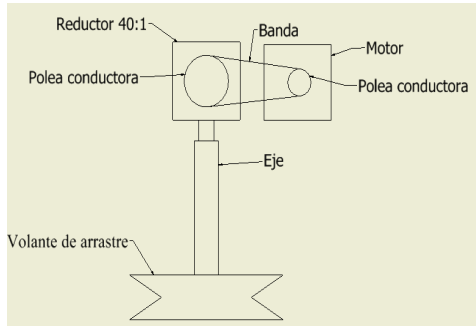

Figure 29: Sketch design of the drive system.

In Figure 29 a sketch of mechanical elements needed for the operation of the drive system shown.

**Wheel drive**

Figure 30 a sketch flywheel drag and design parameters are shown:

- To transmit the torque for driving the system.
- Wheel diameter not exceeding 0.60 m due to the geometry of the monorail.
- The slots for coupling the driving pulleys.
- A splined for coupling the drive chain.
- Permitting Prisoneros flywheel holding the driveshaft.

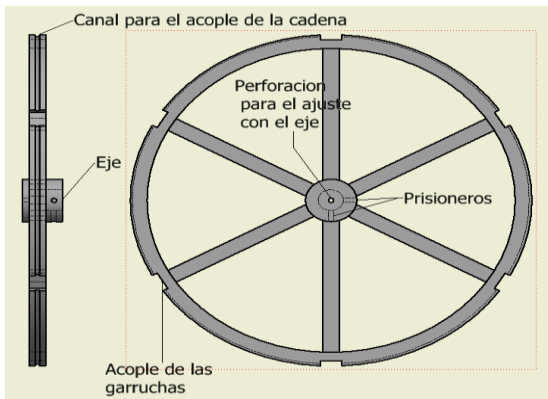

Figure 30: Features for sizing the wheel drag

Then the wheel measures will drag:

- Ø Steering wheel drag. [0,60 m]
- $E_{ga}$ = garrucha thickness, adding a tolerance will. [0,015 m]
- $A_{ga}$ = garrucha with width tolerance. [0,035 m]
- Ø corrugated steering wheel drag tolerance for coupling the drive chain [8 mm].

**Guide wheel**

The guide wheel will be responsible for tuning and guide the chain to close the conveying circuit, will be coupled to a rigid axle, on your block will be placed bearings to facilitate the free rotation in the system; in Figure 31 the wheel guide elements indicated.



Figure 31: The steering wheel and drag elements

**Motor**

To calculate the engine power is necessary to know the amount of inertia that will win, and determine the right time and generate movement.

To determine the torque equation system is used:

$$\Sigma T = \Sigma I * \alpha$$

Where:

T = Torque [N\*m]

I = Inertia of all system elements [Kg \* m<sup>2</sup>]

$\alpha$  = angular acceleration [ $\frac{rad}{s^2}$ ]

The total inertia of the system is the sum of all elements inertia drive system.

$$\Sigma I = I_{ruedas} + I_{pollos} + I_{garruchas} + I_{c \text{ volante guia}} + I_{c \text{ voliante de arrastre}}$$

The inertia of all elements is:

$$\Sigma I = 4162,69 \text{ kg} * \text{m}^2$$

For torque it has the equation:

$$T = \Sigma I * \alpha$$

The angular acceleration is calculated by the following equation taking into account that the motor starts from rest and must maintain a constant speed.

Determine the acceleration of the system with the help of drag wheel must travel a distance of 1.80 m, which is the base of the tub in a time of 90 s; the flywheel arc length is determined drag.

$$S = \theta * r$$

Where:

$S =$  arc length

$\theta =$  angle  $[2\pi]$

$r =$  wheel radius.  $[0,16 \text{ m}]$

$$S = 1,005 \text{ m}$$

With this it follows that in a revolution runs 1,005 m, as we need to know how many revolutions will the distance of 1.80 m we:

$$\text{number of revolutions} = \frac{1,80 \text{ m}}{1,005 \text{ m}}$$

$$\text{number of revolutions} = 1,79$$

With this value the angular velocity of the system is calculated, the calculated speed must be carried out in a time of 90 s.

$$\omega = \frac{1,79 \text{ rev}}{90 \text{ s}} = 0,0198 \frac{\text{rev}}{\text{s}} = 0,125 \frac{\text{rad}}{\text{s}}$$

The motor acceleration time is 5 s and proceeds to calculate the angular acceleration of the system.

$$\alpha = 0,025 \frac{\text{rad}}{\text{s}^2}$$

It is estimated torque.

$$T = \Sigma I * \alpha$$

$$T = 104,07 \text{ N} * \text{m}$$

Determine the engine power torque is calculated, the engine speed is 66 rpm.

$$P_{motor} = \frac{T * \omega_{motor}}{9,550}$$

$$P_{motor} = 719,20 \text{ W} = 0,98 \text{ Hp}$$

The estimated power for the machine is 0.98 Hp. Used engine 3Hp.

### *pulleys.*

To select the pulleys need to find the speed ratio which is between the motor and the speed reducer

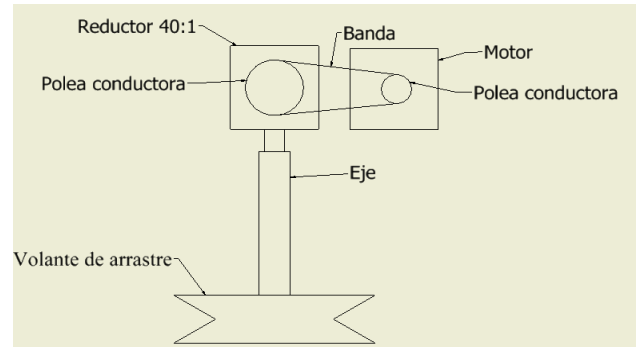

Figure 32.- Sketch of the transmission system and belt pulleys.

The engine that will be used to operate the transport system has a speed of 1410 rpm, it will be regulated with the variable speed drive Sinamics G100, and will have an output speed of the engine 67 rpm which will be reduced by pulleys to the reducer input at a speed of 40 rpm, thus it will be achieved having a speed of 1 rpm, which is the speed required for the work machine.

$$i = \frac{N_1}{N_2}$$

$$i = 1.68$$



**Minimum diameter of the drive pulley**

In Figure 33 we can determine the minimum diameter of the driving pulley to transmit a power of 3 HP at a speed of 67 rpm is 75 mm.

Diámetros mínimos en mm				
Caballos de fuerza (HP)	RPM de Motor			
	900	1200	1800	3600
0.50	65	-	-	-
0.75	65	65	-	-
1.00	65	65	60	-
1.50	75	65	65	60
2.00	75	65	65	65
3.00	75	75	65	65
5.00	100	75	75	65
7.50	115	100	75	75
10.00	115	115	100	75
15.00	135	115	115	100
20.00	155	135	115	115
25.00	170	155	115	115
30.00	170	170	135	-
40.00	210	170	155	-
50.00	230	210	170	-
60.00	260	230	190	-

Figure 33.- Pulley diameters depending on the speed and power.

Source: (Consider, 2010)

**Diameter of the driven pulley**

Once you found the values of the transmission ratio and the diameter of the driving pulley diameter driven pulley is calculated.

$$i = \frac{d_2}{d_1}$$

$$d_2 = 126 \text{ mm}$$

Pulleys are installed on the machine are:

- drive pulley 75 mm
- driven pulley 126 mm

**Bands**

To select the type of transmission band is based with the speed and the calculated power, then you have to pass on to power 0, 98 Hp at a speed of 66 rpm needs a band type B.

**3.3. System power control and temperature control.**

To perform an analysis of the balance of thermal energy is necessary to know how to operate the heat exchanger, the initial conditions, when the temperature of water in the morning of 10 ° C, the burner providing hot air to the surface that runs lights all exchanger, thus achieving heat transfer to the water and have a low temperature air exchanger outlet.

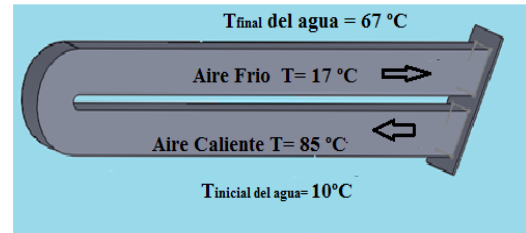

Figure 34: Final condition of the water temperature.

Figure 34 indicates the temperature at which you want to reach, for blanching optimum temperature was taken on the surface of the exchanger, 85 ° C was obtained at admission of hot air and outlet 17 ° C; the final water temperature is 67 ° C on the surface because the hot water is less dense, then the energy balance equation is:

$$\dot{m}_{aire caliente} * h_1 + \dot{m}_{agua frio} * h_2 + Q = \dot{m}_{agua caliente} * h_3 + \dot{m}_{aire frio} * h_4$$



Figure 35.- Enthalpies in the heat exchanger transfer the bath water blanching.

The enthalpies of each stage for heat transfer is shown in Figure 35, the calculation is based on the following equation:

$$h = \int_{T_1}^{T_2} c_p dT$$

Developing:

$$h = c_p (T_2 - T_1)$$

Calculate the enthalpies at each point in the process and heat loss proceeds to find the mass flow of air, Table 2 indicates values calculated enthalpies.

Table 2.- Enthalpy values calculated in each process

	$h_1$	$h_2$	$h_3$	$h_4$
Mass (Kg)		297,8	297,8	
T (°C)	85	10	67	17
$\Delta T$ (°C)	75	0	57	7
Cp	1000	4180	4180	1000
$h(\frac{J}{kg})$	75000	0	238260	7000

Clearing the  $\dot{m}_{aire}$  of the energy balance equation:

$$\dot{m}_{aire} = 1042,13 \text{ kg.}$$

This calculation was based on one hour then air will flow:

$$\dot{m}_{aire} = 1042,13 \frac{\text{kg}}{\text{h}}$$

In conclusion 1042.13 kg is needed to raise hot water temperature air; this calculation is based on one hour

### 3.3.1. Calculating the energy required to raise the water temperature

For the calculation of the energy needed to raise the water temperature of 10 ° C to 63 ° C which is the maximum for scalding poultry the following equation is used:

$$Q_n = m_{agua} * c_p * (T_2 - T_1)$$

Where:

$$Q_n = 65,97 \text{ MJ}$$

The energy required to raise the water temperature to 10 ° C is 63 ° C is:  $Q = 65,97 \text{ MJ}$ .

### 3.3.2. Determine the burner

To determine the burner add the energy required to raise the water temperature and heat loss.

$$P_{quemador} = Q_n + Q_{total}$$

$$P_{quemador} = 66,05 \text{ MJ} = 18,05 \text{ kW}$$

The burner used must be at least 18.05 kW.

### 3.4. Machine structure

The frames should be designed in such a way that supports the entire burden of all systems and elements. It has a total load of 2647 N that are uniformly distributed throughout the structure.



Figure 36: Design of the machine structure blanching chickens.

For gantries will use the profiles PHR C 100 x50, that are suitable for load bearing. The gantry is designed in a case centered compression, in Figure 36 the design of the structure shown.

### 3.4.1. Analysis of the buckling length $I_k$

Depending on the type of wardrobe that will have the backbone to take the value of  $\beta = 0,5$  which it is a pillar bienempotrado.

$$I_K = \beta * L$$

$$I_k = 1.125 \text{ m}$$

**3.4.2. Mechanical slenderness  $\lambda$ .**

It is recommended that the mechanical slenderness of the parts does not exceed the value of 200 on the main elements.

$$\lambda = \frac{I_k}{i_y}$$

$$i_y = 0.56 \text{ cm}$$

PRH selected profile C 100 x 50 mm 2, which has at least one,  $i_y = 5,6 \text{ mm}$ , We take the value of  $i_y = 18,326 \text{ mm}$  that corresponds to our profile selected.

Mechanical slenderness will:

$$\lambda = \frac{112,5 \text{ cm}}{1,832 \text{ cm}} = 61,38$$

$\lambda = 61,38$  Which it is less than 200 satisfies the condition of slenderness.

**Buckling coefficient  $\omega$ .**

The buckling coefficient with the above calculations

For the value of  $\lambda = 61,38$  our part a  $\omega = 1,23$

$$\sigma^* = 768,96 \frac{\text{N}}{\text{cm}^2}$$

Meets the condition

$$\sigma^* \leq S_y$$

$$7,69 \text{ MPa.} \leq 250 \text{ MPa.}$$

The profile that meets the design conditions PRH C is 100x50, with this profile the frame of the machine will be made.

**4. Construction and assembly line scalded**

**4.1. Construction**

Once designed all mechanical systems that make up the scalding chickens machine online by

immersion proceed to build and physically attach parts Figure 37.



Figure 37.- All systems machine coupled

**4.2. Instrumentation**

For the automation of the machine an analysis of how acturan systems with the drive signal, this indicates Figure 38. The temperature sensor that will signal the PLC to hacial burner lights is done, the agitator and the variable speed drive.

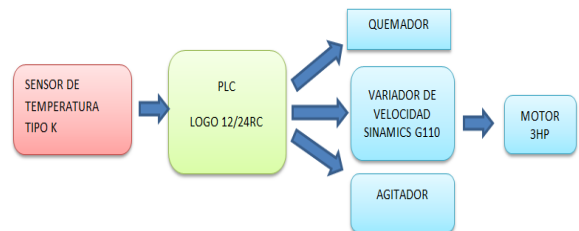

Figure 38: Driving sequence of machine systems

**4.2.1. Type K temperature sensor.**

Following the manufacturer's instructions the following signal conditioning circuit to be implemented to the control cabinet is made. Figure 39.

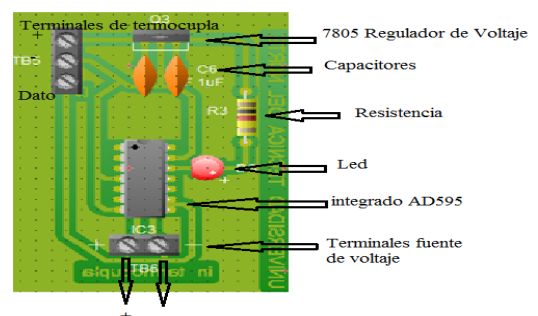

Figure 39: Electric elements on the plate conditioning.

### 4.2.2. PLC programming Logo 12/24 RC.

Logo for programming 12 / 24RC needed a flow chart to determine the analog and digital inputs likewise outputs to drive the machine elements, Figure 40.

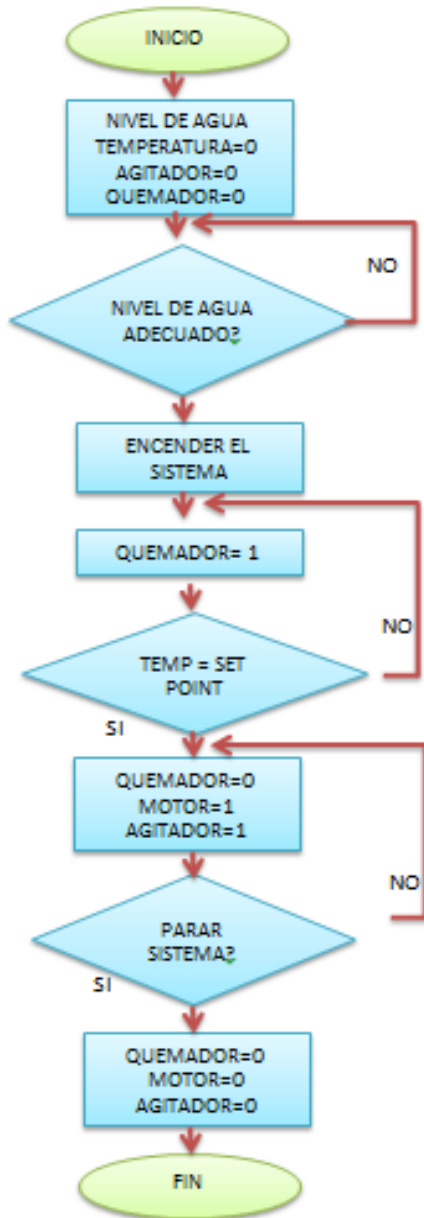

Figure 40. Flowchart machine blanching chickens

### 4.2.3. Programming Sinamics G110 Speed controller of Siemens

According to the catalog (Siemens, 2009)

Parameters must be set according to the data plate engine and user requirements for operation; in Figure 41 the parts shown drive.

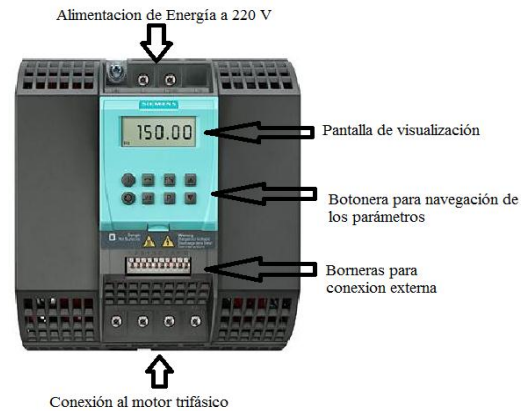

Figure 41: Sinamics G110 frequency converter siemens.

With all the electrical elements of the control panel of the machine is as shown in Figure 42.

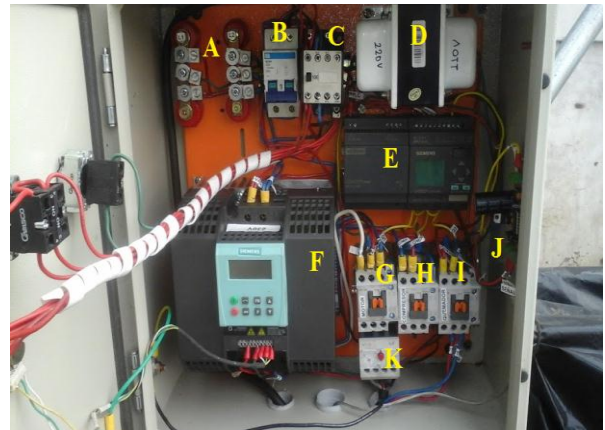

Figure 42: Electrical elements coupled to the control box.

- A: Input voltage lines.
- B: breaker.
- C: Contactor for general on.
- D: transformer voltage 220 V to 110 V for the burner.
- E: Font and Logo RC 12/24.
- F: Variable speeds drive Sinamics G110.
- G: Contactor motor drive.
- H: Contactor compressor drive.

- I: drive Contactor burner.
- J: signal conditioning plate Thermocouple

In Figure 43 external electrical elements for handling machine blanching shown chickens dip.



Figure 43: External elements for machine control.

- A: Selector on power off the machine.
- B: Process Start button.
- C: Stop button or emergency stop process.
- D: Speed regulator for transporting chickens.
- E: Light pilot on the machine.
- F: pilot light is on when the process still does not start or when the emergency stop occurs.
- G: Selector for the type of process chicken.

### 4.3. Cost analysis

Below is an economic analysis that represented the design and construction of the machine scalding chickens dip; This analysis is very important since it allows clarity about the cost incurred in the design and manufacture of the machine and determine whether the implementation of it is feasible; as well as the time that the money invested in the construction of the machine will recover.

The total cost of materials, labor and others for blanching machine, shown in Table 3.

Table 3: Total cost of the construction of the blancher chickens.

TOTAL COST	USD
TOTAL COST EQUIPMENT	4325,76
WORKFORCE COST	5630
TOTAL USD	9955,76

#### 4.3.1. The VAN y TIR blanching machine chickens

The VAN lets us know if the project is viable for implementation.

$VAN < 0$  the project is not profitable

$VAN > 0$  the project is profitable

$VAN = 0$  the project has to be analyzed to be accepted

The TIR is the internal rate of return is also known as the rate of return product reinvestment of net cash flows within the own business operation and is expressed in percentage.

The project has an internal rate of return of 12.80% in 10 months' time this means that this project was made feasible and viable for implementation and the realization of it, from the sixth month money that was invested in the machine recover this being a good time for business.

Besides should take into account for the calculation of net income production 9000 monthly chickens was estimated being possible for this vary according to market demand or high season and Christmas production tripled, thus reducing the time for recovery of money invested in the machine scalded chicken dip.

## 5. Conclusions and recommendations.

### 5.1. Conclusions

With the implementation of the blancher chicken dip is estimated improve the quality of slaughtered chicken in the handicraft industry with a chicken that has no major breaks in the epidermis, a uniform without pigments in the epidermis produced by the water temperature color, low abuse allowing the chicken has more shelf life thus would achieve a better competitiveness with companies engaged in processing and marketing of chicken; besides having a positive impact on the environment due to the low consumption of water for blanching in relation to the other forms studied.

With data collection experimentally the main parameters for a scalded optimum was found, which are water temperature and time of blanching, in this process it was observed that when performing a scalded at an elevated temperature the skin of chickens undergoes cooking at the time of plucking the skin is broken equally to blanch at a low temperature extraction feathers difficult and causing chicken skin pigments for the lack of heat transfer to the follicles.

It conducting a study of different methods for scalding chickens, they proceeded to take essential characteristics for a mechanical design of the blancher then be semi-automated.

The whole structure and mechanical elements of the blancher chickens for dipping production line so that it meets the parameters established for optimal blanching is built. Thus it is estimated to reach production increase  $80 \frac{\text{pollos}}{\text{hora}}$  to  $400 \frac{\text{pollos}}{\text{hora}}$ , because in a cycle delay range 3, 5 minutes transports for 20 chickens.

A user manual for proper use and proper functioning of the machine scalding chickens It is made by dipping.

### 5.2. Recommendations

Once he made the blancher chicken dip was observed that the tub of scalding was very short, if you want to improve production further recommend carrying a tub of greater length, thus achieving increase the speed of transport of chickens by monorriel.

If the size of the tub blanching, likewise increases should increase the length of the heat exchanger, thus achieving exploit the heat generated by the burner; because in this design large amount of heat is detached towards the environment by the fireplace.

For greater energy efficiency it is recommended that the pipe water ingress and air is rolled along the fireplace, to take advantage of the heat released to the environment.

It is recommended that the control box must be as close as possible to the temperature sensor to avoid problems with reading sensor data.

## References

- Amenabar. (2002). Cadenas. Álava: Amenabar.**  
*Análogos, D. (11 de 99). AD595. Recuperado el 12 de 12 de 2015, de Amplificador de temperatura monolitico:*  
<https://www.sparkfun.com/datasheets/IC/AD595.pdf>
- Asahi. (2010). Soporte con rodamiento . Bilbao: Dinamica.*  
*Bavareco, G. (2 de 2006). Procedimiento para el diseño de ejes. Recuperado el 3 de 10 de 2015, de*  
[http://gabpingeneria.weebly.com/:](http://gabpingeneria.weebly.com/)  
[http://gabpingeneria.weebly.com/uploads/2/0/1/6/20162823/diseo\\_de\\_ejes.pdf](http://gabpingeneria.weebly.com/uploads/2/0/1/6/20162823/diseo_de_ejes.pdf)
- Conave. (12 de 05 de 2014). Consumo de pollos subió cinco veces más. El Universo.*
- Consider, E. (2010). Guía de referencia de rodamientos y transmisiones por banda. Canadá: Emerson.*
- INDUMETAVI. (2015). Maquinaria para la industria avicola. Recuperado el 18 de 12 de 2015, de*  
[www.viarural.com.ar](http://www.viarural.com.ar)



<http://www.viarural.com.ar/viarural.com.ar/ganaderia/produccionavicola/insumosparaavicultura/in-dumetavi/transportador-aereo.htm>

*Ingemecánica. (2010). Correas Transmision, Cálculo y Diseño. Recuperado el 18 de 12 de 2015, de <http://ingemecanica.com/tutorialsemanal/tutorialn121.html>*

*Ingemecánica. (12 de 11 de 2015). Resistencia mecánica a la fatiga. Recuperado el 12 de 11 de 2015, de <http://ingemecanica.com/>: <http://ingemecanica.com/tutorialsemanal/tutorialn217.html>*

*Jarrin, J. O. (23 de 09 de 2014). Análisis de la avicultura en el Ecuador. Recuperado el 25 de 10 de 2015, de El Agro: [www.revistaelagro.com](http://www.revistaelagro.com)*

*MAC, I. (2010). Escaldadoras de aspás. Recuperado el 25 de 10 de 2015, de [www.industriasmac.com](http://www.industriasmac.com): <http://www.industriasmac.com/html/Descripcion%20Escaldadoras.htm>*

*Poultry Dressing plant Scalder or Chiken Scalder. (10 de 2013). Recuperado el 25 de 10 de 2015, de [www.alibaba.com](http://www.alibaba.com): [http://in107567697.trustpass.alibaba.com/product/130925312-101439962/Poultry\\_Dressing\\_plant\\_Scalder\\_or\\_Chicken\\_Scalder.html](http://in107567697.trustpass.alibaba.com/product/130925312-101439962/Poultry_Dressing_plant_Scalder_or_Chicken_Scalder.html)*

*Siemens. (2009). Variador de Velocidad Sinamics G110. Alemania: Siemens AG.*

*Tecnologías Limpias. (19 de 01 de 2015). Etapas del proceso de sacrificio de aves de corral. Recuperado el 19 de 01 de 2015, de <http://www.tecnologiaslimpias.org/>: [http://www.tecnologiaslimpias.org/html/central/311107/311107\\_ee.htm](http://www.tecnologiaslimpias.org/html/central/311107/311107_ee.htm)*

*Valenti, M. (09 de 2013). Metalúrgia Valenti. Recuperado el 22 de 10 de 2015, de <http://www.metalurgicavalenti.com.ar/>: <http://www.metalurgicavalenti.com.ar/tanque-escaldador.html>*

## ABOUT THE AUTHOR



Mauricio R. Sánchez T., born in Otavalo – Ecuador the 21 of march of 1989. He studied at the colegio Experimental Jacinto Collahuazo. He completed his studies at the Técnica del Norte University in the race Ingeniería en Mecatrónica in the 2016.

Areas of interest: automation and process control,  
Electronics, Renewable Energy  
Contacto: [mausanch03@hotmail.com](mailto:mausanch03@hotmail.com)