

Iudic-didactic teaching to develop basic gross motor skills in children 3 to 6 years through a wireless electronic game with OpenSource tools

Ariana Anrrango Author, director Omar Oña
 adanrrangos@utn.edu.ec, oronia@utn.edu.ec
 North Technical University

Abstract - This work presents a selection of titration sensors capable of developing basic gross motor skills in children aged between 3 and 6 years. For which three modules consisting Walk straight eyes closed or open, MODULE MONTESSORI was performed. With which the postural control and balance, and can determine whether it has Ataxia (unsteady gait, jerky movement) and stimulate the vestibular system (spatial control, developed ear) is developed; with open eyes the child will strengthen their coordination, achieving a concise definition of colors; Coordination of left foot, right foot on the march. Stand on one foot three or four seconds, MODULE SOBREPÍE. With which equilibrium is developed, achieving strengthen the central nervous system, sensory and kinesthetic system, preventing the child present time vertigo. Walking to the beat of the music, MODULE MUSIC. With which natural movements of locomotion will be developed, the electronic toy will be implemented at the Children's Center "Maria Olimpia Gudiño" the Municipality of Ibarra.

I. INTRODUCTION

The vestibular system goes hand in hand with the nervous system, this system is very underdeveloped in children's centers at ages 3 to 6 years, so it is important to promote the development of this system contributing in the process of formation of the child not having difficulties spatial control and balance. Similarly not knowing the progress of child development by who provides the edutainment based on indicators and records historical and automated way, produce delay in the process of learning and teaching to not have an adequate system storage and processing of reliable data so it is important to promote the development of this system contributing to the formation of the child to have

difficulty spatial control and balance. Similarly not knowing the progress of child development by who provides the edutainment based on indicators and records historical and automated way, produce delay in the process of learning and teaching to not have an adequate system storage and processing of reliable data so it is important to promote the development of this system contributing to the formation of the child to have difficulty spatial control and balance. Similarly not knowing the progress of child development by who provides the edutainment based on indicators and records historical and automated way, produce delay in the process of learning and teaching to not have an adequate system storage and processing of reliable data

To encourage playful-didactic teaching will contribute to the development of motor skills, nerve and vestibular systems in children 3 to 6 years old Children's Center of Ilustre Municipality of Ibarra managing to fill with interest the child to perform series exercises that is made available, such as the walk straight eyes closed or open contributing to the development of the nervous system and basic gross motor skills, stay on one foot three or four seconds after that the child has a good balance, is obtained results we can observe the progress of the learning process of the child through a friendly interface.

II. BASIC CONCEPTS

A. *Teaching*

The best way to educate and allow students to learn is to teach and assess their own learning process, together with the procedures and applications used in education.

North Technical University. Ariana de los Angeles. ANDplayful-didactic nseñanza to develop basic gross motor skills in children 3 to 6 years through a wireless electronic game with OpenSource tools, January 2018

B. Pedagogical methods of teaching

Pedagogy is the science that deals with education and teaching, for this reason it is essential to mention methods that help teachers help children learn.

Suitable methods to be used to impart a fun and educational teaching children, and meet the conditions set in this job qualifications are: Method Agazzi, Froebelian method, Montessori Method and personalized education. Different methods were chosen because they have to play the main feature, aim to teach children in an organized, concise and effective manner, with a path that ensures learning by encouraging the use of different objects guaranteeing interest children learn.

C. The edutainment

It is the way to teach through play. According to (Piaget, child psychology, 1997) "Knowledge is not obtained from the objects but actions performed on objects" (p. 22).

So playful an alliance between culture and intelligence is done in the period of initial life of a child / a.

D. The driving game

The driving games have multiple beneficial features that make it a very important means for anyone who is linked to the educational, recreational or personal space, with children / as and they have the need to move (Dragu, Dobrota, & Ploesteanu, 2011) . Therefore we can say that driving games are a natural activity that satisfies the demand for the smallest movement.

E. TIC'sy the edutainment

Education in measuring basic indicators of ICT for example, the proportion of teachers with expertise in the field of technology is important.

- Facilitate and inspire learning and creativity of the student.
- Design and develop learning experiences and assessments in the digital age.

- Modeling work and learning in the digital age.
- Promote and model digital citizenship and responsibility and safe environments linking.
- Promote growth and professional leadership

F. Stages of cognitive development Piaget

Piaget presents four stages of development, which are:

- sensorimotor stage: From birth to two years old.
- pre-operational stage: from two to seven years old.
- Stage of concrete operations: From seven to twelve years.
- formal logical step: From twelve to sixteen.

These stages is said that children in the Children's Center Ilustre Municipality of Ibarra are in the pre-operational stage, where skills development is important, using the sensorimotor intelligence so that the child can get involved with their environment environment and can develop properly, because the child is in a representation system and uses symbols such as words to represent people, places and events, preoperative intelligence is developed thanks to the sensorimotor by creating suitable conditions intelligence. .

G. basic motor skills

Motor skills sometimes known as Basic motor skills are those solutions to "problems" that a person faces in different situations through movements.

Motor skills can be defined as "control the child / a is able to take over her own body," according divided into two movements:

- **Gross Motricity:** Develop, control and awareness of the large muscle activity such as jumping, running, jumping, etc.
- **Fine motor:** Develop, control and awareness of different activities and fine movements where

North Technical University. Ariana de los Angeles. ANDplayful-didactic nseñanza to develop basic gross motor skills in children 3 to 6 years through a wireless electronic game with OpenSource tools, January 2018

the different movements of fingers, eyes combined, hands and tear, paint, etc.

H. gross motor skills

Early age from three to seven is important as the development of motor skills takes. In this period the transition to the consideration that the child must pass, from basic motor skills to perfection of these achieving proficiency in games and sports skills. Thus in recent times it has chosen to make instruments, tools that are aimed at developing gross motor skills. (Delval, 2006a).

I. Relationship of the nervous system and vestibular system with the proper development of gross motor skills

It is important to know the relationship of the nervous system with the vestibular system, since the skills that will be developed in this work qualifications relate to each other.

I) *Nervous system*: While it is true it is said that the development of a skill promotes the development of another, ie organs and systems must operate in coordination, this being possible thanks to the nervous and endocrine systems, stressing that the nervous system is only fully developed to age of 15 or 16 years, then it is important to note that a very significant role is played the right formation of mental structures. (Piaget, 2001d Yankovic, s.fa). Advances in engine type, also called motor skills, follow the development of the nervous system and are guided by sensitivity. (Delval, 2006b).

II) *vestibular system*: Vestibular stimulation is responsible for regulating the direction of movement and balance, which allows placing the body in space travel and the environment. (Flores, 2015a). And in any case it requires high levels of body control. "On one hand it is necessary to keep upright and move on unstable materials such as wheels and the other are continuously turns occur" (Anglada, 2014).

J. Specific features and vestibular nerve to develop electronic game system.

Knowing the relationship of the two systems together, you can now present the characteristics

involving each of them, taking into account that these characteristics are based on the skills development work described titration. A specified below and explain each.

I) *Display*: The sense of sight dominates and overcomes the other senses, because you are you can see the distance between the object and the subject, may establish references, and follow the object contrasts with the view. Sn But sometimes the subject information collected may confuse the balance when running some complex physical movements. (Friar, 2012a, p 11-12;. Flores, 2015c). The colors express moods and emotions of very specific psychological significance, also exert physiological action. (Tomorrow Group, 2006).

In figure 1 a diagram is shown cake and home section is a color with its meaning.



Figure 1: Explanation of basic colors.

Thus it is important that children can watch a game in primary colors like blue, red and yellow; side like purple, green and orange colors each contributing to the development of the sense of sight either together or individually.

II) *Hearing*: The sense of hearing its main function is to stimulate the balance. The ear lies in the vestibular system consists of the lobby. (Friar, 2012b, p. 1112).

The music has a positive effect on the nervous system being introduced at an early age, thus having the ability to arouse feelings and moods they bring to order, serenity and control consonant sounds. Thus it can be said that the reproduction of the correct musical notes

North Technical University. Ariana de los Angeles. ANDplayful-didactic nseñanza to develop basic gross motor skills in children 3 to 6 years through a wireless electronic game with OpenSource tools, January 2018

encourages learning in children causing them order and serenity when performing any type of activity, it is important to mention that the auditory system of the child is developing ages 3 to 6 years, for that reason should be sought sharp consonants and musical notes will chord development.

III) Postural control: The position according Kendall, Kendall, & Wadsworth (1986) is defined as "the composition of the positions of all joints of the human body at all times". a balance in the anterior and posterior muscles of the body to maintain posture is necessary. And the purpose of postural control is to guide the different parts of the body preventing loss of balance, the body itself and in relation to the external world, whether the body is moving or static. (Martin, 2002a).

III) Balance: You can say that balance is the ability to assume and maintain a certain posture against gravity. It is related to the central nervous system and information hearing, vision, and kinesthetic system which is responsible for informing the child / a body position and muscle movements needed. (Valdiviezo, 2014; Flores, 2015d). The balance goes hand in hand with the nervous system and the vestibular system, being an essential feature of development in this work degree, the proper development of balance will allow the child to be deployed gradually skills such as muscle, the view , ear, tendons and nerves. The types of balance movements help verify that children / as made.

K. OpenSource platform

OpenSource is also called "Open Source" knowing this way the software distributed and developed a free, HE lasifica in [raspberry Pi](#) Y [Arduino](#). The OpenSource work platform used in the titration was Arduino

I) *Arduino*: Arduino is an electronic prototyping platform open source (open-source) with hardware and very flexible and easy to use software. Arduino is intended for artists, designers who want to create interactive objects or environments. (Herrado, 2009). In the space of Education it has opted for the development of electronic platforms that seek to solve specific problems, just as essential and basic knowledge of application programming or electronic

development is provided. So now people of all ages to enter the world of programming and development of electronic projects or prototypes (Arenas, 2014) are encouraged.

L. Wireless communication technologies

Wireless communications are those communications between devices (mobile or otherwise) or between persons who exchange information using the electromagnetic spectrum (Blazquez). Ie no wires or physical media through which information passes, in this way the signals travel in waveform radio space, whether or not there is air, from one point to another point is needed. The wireless technology used for communication is the Bluetooth technology.

I) Bluetooth. It is a technology that is described in Figure 2:



Figure 2: Key features of Bluetooth technology.

M. Software development process

For proper development of electronic toy you need to follow a methodology, so results that meet the needs of users are obtained. For this reason it is established that (Valdéz, sf) "For the design and development of software projects methodologies, models and techniques to solve problems apply". Using the V model to develop work degree.

I) The model V or four levels: This model is a model variation cascade presents how design activities relate to tests and finally the coding with the analysis and design to the left and testing and keeping to the right. (PMO, 2010). At levels 1 to 4, logic levels, relates for each stage of development, there is a corresponding verification phase, so it is important to have a result that the check done. (UDT-IA, 2008). In Figure 3 the model shown in v.

North Technical University. Ariana de los Angeles. ANDplayful-didactic enseñanza to develop basic gross motor skills in children 3 to 6 years through a wireless electronic game with OpenSource tools, January 2018

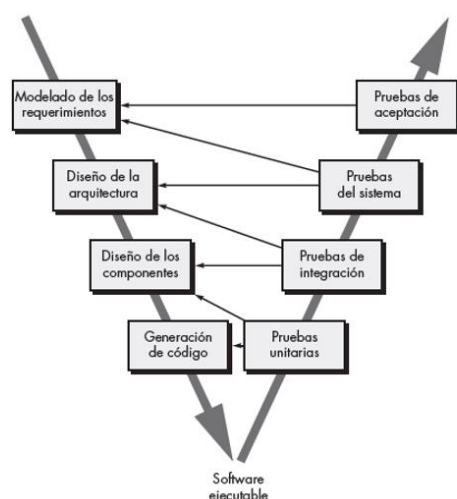

Figure 3: Model V or four levels.

III. EXPERIMENTAL DEVELOPMENT

A. Analysis of the current situation

Bibliographical, field research, direct observation and survey, four research techniques that are used.

The literature search was based directly on gathering information about the basic gross motor skills as children and their development.

Field research in conjunction with the direct observation was conducted at the Children's Center of the Municipality allowed to reach the conclusions that if there are tools that are able to develop basic motor skills can be classified into traditional and technological, traditional: packing tape or thick cord that is placed in the floor, which a chalk line on the floor and draws Technology: any tools to develop motor skills. The tools with which the teacher works are not updated with regard to motor skills, sense of sight and hearing. It could make several observations as sight develops games in either a tablet or paper, in which it interacts with colors, primary and secondary; ear develops placing music on a tape recorder; for gross motor skills using traditional tools. The degree of student participation is very good and interest perform activities by children is very good. Aspects of the class are

- **Colors:** Green, yellow, blue, red, purple, pink
- **Animals:** lion, giraffe, cat, dog

- **figures:** square, round, triangle

total of 5 surveys teachers of children Children's Center, with the result that today teachers still use traditional methods for developing gross motor skills, such as a rope or a line drawn on the performed flat, despite that have technological tools in the classroom there are not enough tools to develop them. Teachers / as fully known the concept of edutainment, which becomes dispensable for the implementation of an electronic game as a learning tool in the classroom is great reception, but this does not mean that all teachers use this tool, however, most teachers would be willing to use new technological tools to help stimulating basic motor skills. What makes development and implementation toy for children and teachers supervised by a technological, simple and consistent with the needs of children / as / teacher required tool.

B. System Requirements

According to the system requirements all the requirements under the IEEE 29148 standard is specified based on Stakeholder or elements that determine the correct operation of the system.

C. Hardware and Software Selection

We analyzed the requirements of the system was performed two systems, one system Giraffe and other mobile system. For the giraffe system shown in Figure 4 is selected:

Sistema Jirafa	
<input type="checkbox"/> Placa Electrónica Arduino	<input type="checkbox"/> Módulo mp3
<input type="checkbox"/> Sensor de Presión	<input type="checkbox"/> Amplificador
<input type="checkbox"/> Sensor Infrarrojo	<input type="checkbox"/> Filtros de Audio
<input type="checkbox"/> Sensor de Vibración	<input type="checkbox"/> Parlantes
<input type="checkbox"/> Módulo Bluetooth	<input type="checkbox"/> Alimentación
<input type="checkbox"/> Barras Led	

Figure 4: List of electronic elements within the system giraffe

Likewise for the mobile system in Figure 5 the elements shown implemented:

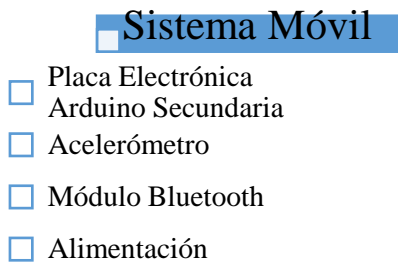

Figure 5: List of sensors and electronic elements found within the mobile system

Hardware for selection was based on the structural requirements and a toy animal form was designed, toy has a shape of an animal, like a giraffe, which in children / as may stimulate the desire to play, drawing attention for its design. In addition, it is taking into account that the giraffe has a long neck, so this part of the animal's body to the traditional rope or line drawn on the floor will be replaced. 6 shows the design of the structure that have the electronic toy:



Figure 6: Design of the structure of the electronic toy in Adobe Illustrator

D. System design

As part of the system design is shown below the guide block diagram operation, layered software architecture and system context.

I) Block Diagram: A general block diagram presents graphically the fundamental parts design electronic toy, which is presented in Figure 7.

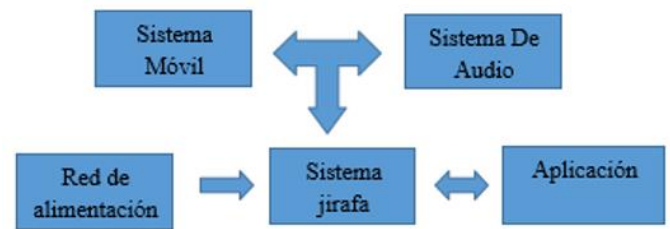

Figure 7: general block diagram of electronic toy

1. **Mains:**Feeding all electronic design is alternating current with a transformer to direct current (AC / DC). This voltage was able to feed all the electronics.
2. **giraffe system:** Electronic elements that obtained data and then processed. We worked with three sensors for the execution of Montessori, Sobrepíe and Music modules. Which they are: Infrared sensor, vibration sensor, pressure sensor, working with the main electronic board, covering the detection of a movement or weight on a surface.
3. **Mobile system:** In this block working with Accelerometer for Montessori execution module, the secondary circuit board is implemented.
4. **Audio system:** In this block elements audio output indicators, electronic elements that will complement the Montessori, Sobrepíe and Music modules used.
5. **Application:**With the game control system is available to the user the choice of module to be executed, allowing the receipt and processing of data. Developing a user-friendly interface allowed the teacher / to have access to the actual data from the electronic toy.

II) layered architecture: This architecture is based on that in each of the layers is carried out such that operations come to a result set of machine instructions and in Figure 8 the distribution of the layered architecture shown.

North Technical University. Ariana de los Angeles. ANDplayful-didactic nseñanza to develop basic gross motor skills in children 3 to 6 years through a wireless electronic game with OpenSource tools, January 2018



Figure 8: Architecture Layered

IV. IMPLEMENTATION

We proceed to implement the elements of the above two systems.

A. Giraffe connection diagram system

Figure 9 shows the connection diagram of all the sensors and electronic elements found in the system shown giraffe.

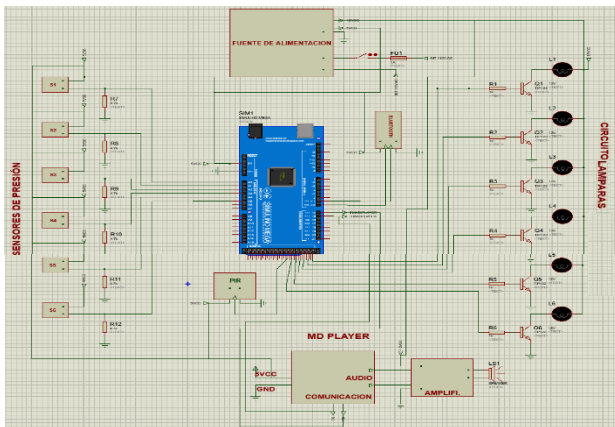

Figure 9: Diagram sensor connection system giraffe

I) Pressure Sensor Square: Pressure sensors will operate in two states, when the child apply pressure or when not acting in any way, ie a High or Low state, is why it is necessary that the pressure sensors are in resistance Pull - Down . To assemble the pressure sensors one data collection was carried out for the correct way to implement without affecting data collection tread child. In Figure 10 the result of the implementation of the pressure sensors shown

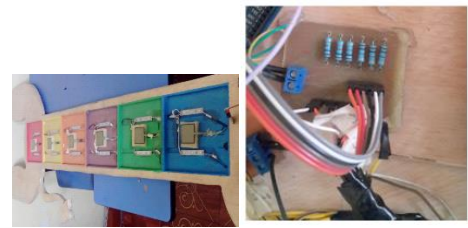

Figure 10. Connecting structure and bakelite pressure sensors

II) Infrared Sensor: The infrared sensor PIR acts as verifier end of Montessori module in the structure giraffe must be assembled sensor at the end thereof, ie in the head, considering that the sensor position is strategic since it covers possible ranges crossing the body of children, by measuring the angle that is capable of censusing the PIR due to its plastic lens, in figure 11 we can see the result of the assembly and the circuit board.



Figure 11: Assembly and infrared sensor plate welded front view and rear view tracks.

III) Led Bars: In each frame of the neck of giraffe are placed two LED bars, one in each slot together in row vertically connected to a common positive, it is important to mention that it was necessary to use a circuit capable of regulating the light intensity the LED bars, the light intensity of an LED is proportional to the intensity of current flowing through the same, in this case 1.08 A so important to use an electronic element to allow control of the flow signal is delivered on the basis Arduino transistor by a pin PWM transistor TIP-120.

North Technical University. Ariana de los Angeles. ANDplayful-didactic nseñanza to develop basic gross motor skills in children 3 to 6 years through a wireless electronic game with OpenSource tools, January 2018

The indicated position of the LED bar is adequate to attenuate light so that visible to the child also Bakelite shown in Figure 12.

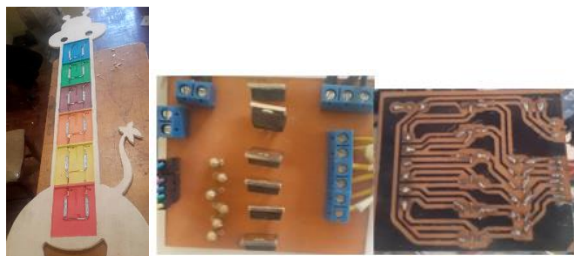

Figure 12: Position, bakelite connection of the LED bars

IV) Audio System: For audio system mp3 module df player, which has the capability and ease of playing sounds, music, musical notes previously recorded on your SD card, which has a number of memory almost 10 times more than was used the WTV020 DS-16P module also takes into account the mp3 and WAV files, which makes use of the module df player a simple procedure for audio amplification and noise correction amplifier module using TDA2030 audio, which features an integrated type TDA2030 with a heat sink circuit, being a monolithic integrated circuit. signal very small audio obtained from a sound source is amplified. Board audio system is shown in Figure 13:

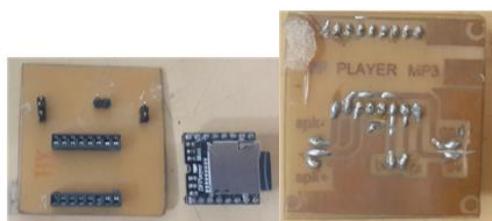

Figure 13: Plate audio system front view and rear view welded tracks

V) Power supply: To supply all electronic elements implemented in developing the giraffe system one CCTV 12 volt supply which meets the specifications required to power the electronics used has a current of 2 Amps, taking note that the actual value of the giraffe system consumption is 1.5 a, it is efficient to use this source.

B. Connection diagram Mobile System

In Figure 14 the connection diagram of all the sensors and electronic elements found in the mobile system is shown.

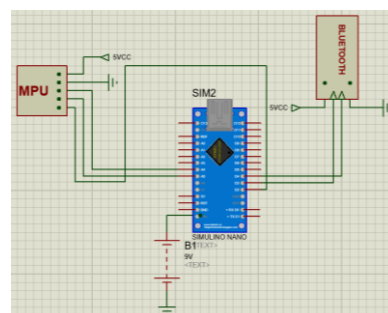

Figure 14. Diagram of connection of the mobile system

I) Accelerometer: Mobile system is necessary to determine the position in the child's body, for which the accelerometer mpu5060 is indicated as it is essential to know when the child has lost balance and thanks to this integrated circuit that detects the acceleration of Earth's gravity with these readings will be possible to know the angle of inclination relative to the axis X or Y axis, ie if the child in the march unbalances sideways. It has a gyroscope that adding the angle we know the angle of imbalance at every moment. In Figure 15 the system assembly and plate elements shown



Figure 15: Position and plate accelerometer

II) Power supply: The power supply because the mobile system is independent of the giraffe system, it is important to mention that the power should be taken equally well a rechargeable battery which generates a voltage of 8.4 volts with a load of 1.2 A was used / h, this battery does not require a voltage regulator since the Platform is built Arduino Pin Vin, which serves as a voltage divider through its internal regulator

North Technical University. Ariana de los Angeles. ANDplayful-didactic enseñanza to develop basic gross motor skills in children 3 to 6 years through a wireless electronic game with OpenSource tools, January 2018

B. GUI design

Based on the requirements of the design of the user interface thanks to the application made in free software App, which was installed on the mobile phone of the master was performed, allowed to monitor the progress of the development of basic gross motor skills in children , when performing each of the modules you can keep track of scores helping development evaluation.

Screens design of the user interface are shown below.

I) *Home Screen:* In Figure 16 the screen seen by the user when opening the application is shown.

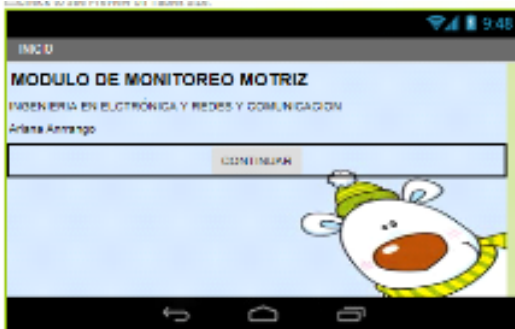

Figure 16: Home screen app

II) *Menu display modules:* In Figure 17 the screen where the user can choose you want to do is displayed, if the user the first time students must register.



Figure 17: Menu display

III) *registration screen Students:* In Figure 18 the student registration screen, where you have observed the following buttons:

- **New:** Enter a new student
- **To update:** Modify data of a student

- **Remove:** Delete data from a student
- **To show:** Show the data entered



Figure 18: Student Registration Screen

IV) *montessori screen module:* In Figure 19 the first module screen is displayed, specifying each item containing the display.

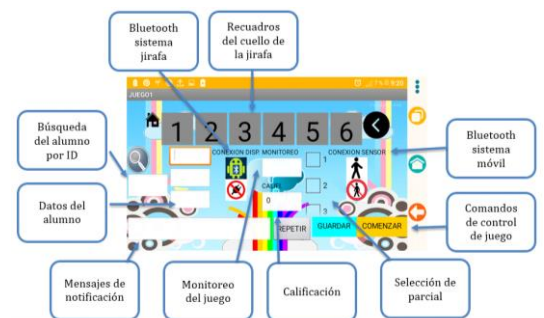

Figure 19: Display module montessori

V) *sobrepie screen module:* In Figure 20 the design of the user interface of the second module is further shows each element is specified in the screen.



Figure 20: Display module sobrepie

VI) *screen music module*: In Figure 21 the elements found in the third screen module.

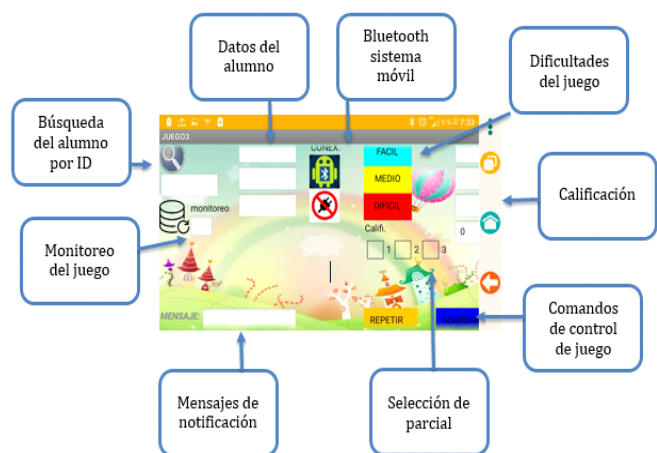

Figure 21: Music screen module

C. *Functionality test*

Performance tests are conducted with the children 3 to 6 years old, testing each of the modules, then the process of children observed by modules

I) *Montessori Module*: Sand can be seen in Figure 22 coordination that the child has to start up right foot, left foot. Was developing under the Montessori module boy observes the color change of the boxes according to their march.



ID	NOMBRE	APELLIDO	EDAD	JUEGO1		
				1	2	3
8	Daniel Fernando	López Ben alcazar	3	60	66	87

Figure 22: Sequence Montessori final test photographs.

II) *Module Montessori covered eyes* can be seen in Figure 23 that the postural control of the child is maximum, although at the beginning of module development has had minimal imbalance, unassisted, without leaning on the wall, tilt the body to the sides abruptly or exit the game the child has a good balance. The spatial control is determined empirically, which based on the photos get to clearly see that the child has a satisfactory spatial control. Lacking the sense of sight, the sense of hearing becomes alert, so notification sounds if you make a mistake, they become fundamental and indispensable for the completion of the module stimulate the development of hearing. The teacher knew how to express that Daniel has a stable ride, even at the beginning seemed to wane,



ID	NOMBRE	APELLIDO	EDAD	JUEGO1		
				1	2	3
8	Daniel Fernando	López Ben alcazar	3	70	80	76

Figure 23: Sequence of tests pictures final Montessori covered blindfolded.

III) *Sobrepié Module*: sand can be seen in Figure 24 the balance that the child has to stand on one foot for 4 seconds, at the start in the red box test the child leans against the wall in order to establish balance, however during the second remaining remains in a constant position, over the module can observe the balance of the child's body.



North Technical University. Ariana de los Angeles. ANDplayful-didactic nseñanza to develop basic gross motor skills in children 3 to 6 years through a wireless electronic game with OpenSource tools, January 2018

ID	NOMBRE	APELLIDO	EDAD	JUEGO1			JUEGO2		
				1	2	3	1	2	3
7	Diego Felipe	Estevez Anrrango	6	59	87	86	60	80	100

Figure 24: Sequence of photographs sobrepie test module.

IV) *Module Music*: En the next series of photographs of Figure 25 the girl develops the music module with difficulty. The girl despite the difficulty can be seen that the movements performed during development are natural locomotion. It is noteworthy that the child continues to perform its ballet positions.

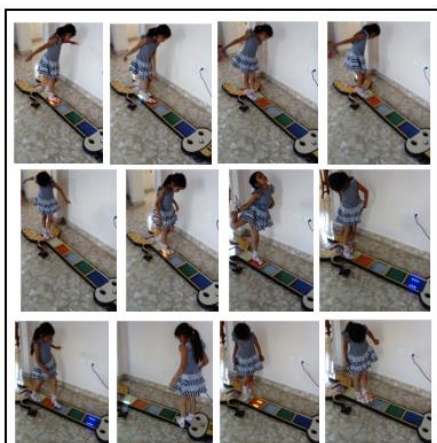

ID	NOMBRE	APELLIDO	EDAD	JUEGO1			JUEGO2			JUEGO3		
				1	2	3	1	2	3	1	2	3
5	Domenica Isabela	Venegas Anrrango	5	94	68	99	100	60	80	79	66	63

Figure 25: Sequence of photographs music module tests

For performance tests conducted thanks to a c, It follows that the Montessori module with open eyes has a total percentage increase of 40.3% which makes it feasible as a tool for developing basic motor skills thick, as is the march, likewise coordination the walk and the view. Was I able to determine if children have an unsteady gait (ataxia), with the Montessori module and children with the sense of the dominant view, if the child will walk properly its position in the same way it will be, so it got a stable with proper postural control walk, so does the sense of sight was stimulated as the child progressed, the boxes changed colors, each color emits

a different feeling in children, so the initial color (red) and end (blue) are fundamental,

The Montessori blindfolded module has a percentage of 44.7%, which makes it feasible, this module is based on replacing a fundamental sense in children as is the vision, the sense of hearing, which the process is arduous, however it came to develop skills such as postural control, balance can determine the final test if the child has ataxi (unsteady gait, espamódico movement) and stimulation of the vestibular system (spatial control, development of hearing).

A walk straight right foot, left foot is the correct process module Montessori blindfolded whose qualitative result increased postural control of the child with a correct body position.

With a percentage increase of 50%, the module is feasible Sobrepie what makes this module a tool that successfully develops balance and basic gross motor skills of children. The position of the child's body during time set in each box allowed the development of the central nervous system, actions that the child performed guided by the sensitivity of being on foot, sensory system, assimilate the information of new sensations and kinesthetic avoiding the child has vertigo, the sense of sight in each practice module is encouraged by change notifications standing over 4 seconds.

Feasible being the music module with a percentage increase of 42.8%, it can be said that this module supports the development of the natural movements of locomotion, if you also hate and sight. Natural movements of locomotion are presented in the way of getting by children a hit in each of the difficulties, the music low frequencies got the sense of hearing is stimulated at all times, like the sense of view and empirical results of the mood of the child is also obtained, with a serene leaving the adrenaline that a 3 to 6 years is the development of the module status.

V. CONCLUSIONS

It was possible to develop an electronic game that encourages playful learning - teaching children from 3 to 6 years reflects the development of basic gross motor skills and transmitting data from the electronics via

North Technical University. Ariana de los Angeles. ANDplayful-didactic enseñanza to develop basic gross motor skills in children 3 to 6 years through a wireless electronic game with OpenSource tools, January 2018

Bluetooth wireless communication to an interface display on an Android device.

The core of the project is based on parameters that develop basic gross motor skills, different research techniques used allowed to establish those parameters with which it was possible to know the current situation of child center with respect to the basic gross motor skills, concluding that replace traditional methods for electronic toy helped bring a visible advancement of skills.

The design of the three Montessori, Sobrepie and Music modules allow the correct assessment of the development of gross motor skills basic mainly balance, postural control, sight and hatred, as well as promoting educational edutainment in the classrooms of Children's Center Municipality

Follow a kind of methodology allowed to follow step by step development work titration using the V model where the necessary requirements established for the proper development of electronic toy focusing mainly on performance parameters such as; Type reading method, RAM, number of sensors, user friendly application, version bluetooth technology to use, power supplies, materials physical structure, all the above requirements ensured optimal performance.

Performance tests that were conducted at the Children's Center of the Municipality were able to establish an assessment of the development of skills in real time, also by the friendly user interface was observed an increase in the rating scores obtained by each children employed as the electronic toy, plus continued use of the toy I contribute to motor learning in a playful way.

VI. RECOMMENDATIONS

Development of bibliographic research is recommended to use sources of verified information, you can get information related magazines in the field of pedagogy, based on teaching, scientific articles that relate to the part of medicine in the areas of systems develop, it is also advisable to follow the guidelines fully quotations and references established by the rules Apa version six.

Using Arduino open source allowed to have a considerable advantage not having any restrictions on licensing fees for one-time use, which allows an innovative, educational, recreational and system free of any license fee, he was also the basis of the embodiment of the three modules, as it allowed an extensive but understandable programming, using appropriate each of the elements libraries, call correct and different methods of software development variables it failed to meet the needs of each modules.

The selection of different types of sensors is advisable to do with the help of a literature search, then testing operation of sensors, in this case the function tests vibration sensor separately was a success but by uniting all sensors in the structure was obtained too many mistakes, so it is important to test the sensors in different environments and in different ways to consolidate their use in the project

The selection of different materials for the physical structure of the project is advisable to do with the help of an expert who knows the manufacture of toys or is in the development of materials that can be considered also to be taken into account to whom it is toy directed to take appropriate precautions, know the benefits or disadvantages of using any alternative material.

App inventor allowed a programming simple blocks, although extensive resulting in a user-friendly application with the user, an application that supports Android devices, which is convenient because in the children's center has 10 tablets with this operating system, Manual operation is useful for teaching and a teacher who will use the application for the first time.

The significant playing time authorized by the teacher because it was the most suitable for children to use in a favorable way the electronic toy, time that allowed children do not show boredom, fatigue or disdain.

The edutainment - teaching you set the electronic toy was a great host, the theory presented Piaget put perspective of the teacher where children represented the by expressing achievements in shares of jubilation at the end of the modules of the electronic toy.

North Technical University. Ariana de los Angeles. ANDplayful-didactic nseñanza to develop basic gross motor skills in children 3 to 6 years through a wireless electronic game with OpenSource tools, January 2018

REFERENCES

- [1] Piaget, J. (1997). Child psychology. Madrid, Spain: Morata.
- [2] Dragu, M., Dobrota, C., & Ploșteanu, C. (2011). The place, role and Importance of Motor games in the physical education lesson for secondary school Pupils. 152-159.
- [3] Arduino. (2015). Arduino. Retrieved from <https://www.arduino.cc>
- [4] Acuna, M. (sf). virtual game strategy for teaching environmental education in preschool children. University of Santiago de Chile UNAB, Santiago de Chile.
- [5] Kendall, H., Kendall, F., & Wadsworth, G. (1986). Muscles, and test functions (2nd ed.). JIMS.
- [6] Arenas, M. (2014). Arduino, the brain of the Smart City. Retrieved from <http://www.smartscities.com/index.php/tecnologia/item/124-arduino-el-cerebro-de-la>
- [7] Flores, S. (June 2015). Vestibular Stimulation and Development of Balance in Children / Hearing Impaired as 4 to 5 years old at the Institute of Special Education Pastaza. Ambato, Ecuador.
- [8] Ruben, J. (February 21, 2014). GeekFactory. Bluetooth obtained HC-05 and HC-06 Configuration Tutorial: <http://www.geekfactory.mx/tutoriales/bluetooth-hc-05-yhc-06-tutorial-de-configuracion/>
- [9] Bustamante, G. (July 2011). Statistical sampling approach to scientific research. . Journal of Clinical Research Update, 10, 3.
- [10] Ecommerce Mexico. (Sf). LED lighting strips. Tiraslediluminacion obtained from: <http://tiraslediluminacion.com.mx/blog/noticias/302-que-son-las-tiras-led-y-comofuncionan>
- [11] Electronics Area. (27 May 2015). Unicrom. Obtained Amplifiers - Amplification: <http://unicrom.com/amplificadores-amplificacion/>
- [12] Sarmiento, E. (2009). Design and implementation of a prototype home assistant, case study autonomous vacuum cleaner. Polytechnic School of Chimborazo, Faculty of Computer Science and Electronics, Ambato.

Ariana D. Anrrango Sanguino, Author



He was born in Ibarra Imbabura province on 22 July 1999. He did his secondary education at the Unit Educativa Sacred Heart of Jesus "Bethlemitas" obtaining the bachelor's degree in the specialty of mathematical physicist. Currently, he is a graduate of the Technical University in North Engineering Degree in Electronics and Communication Networks.

Omar R. Oña Rocha, Director



Professional Electronic Engineering yTelecomunicaciones. He currently teaches at the Faculty of Engineering of Applied Science (FICA) at the Technical University of North Race Engineering in Electronics and Communication Networks (CIERCOM), in areas such as electrical circuits, electronics, electronic circuits, digital systems and related fields. He has experience in the field of technical advice, preventive and corrective computer equipment, installation and maintenance of network maintenance. Through his service he worked constantly and unconditionally in the development of electronic and telecommunications projects